

REVISIONS			
REV.	DESCRIPTION	DATE	APPROVED

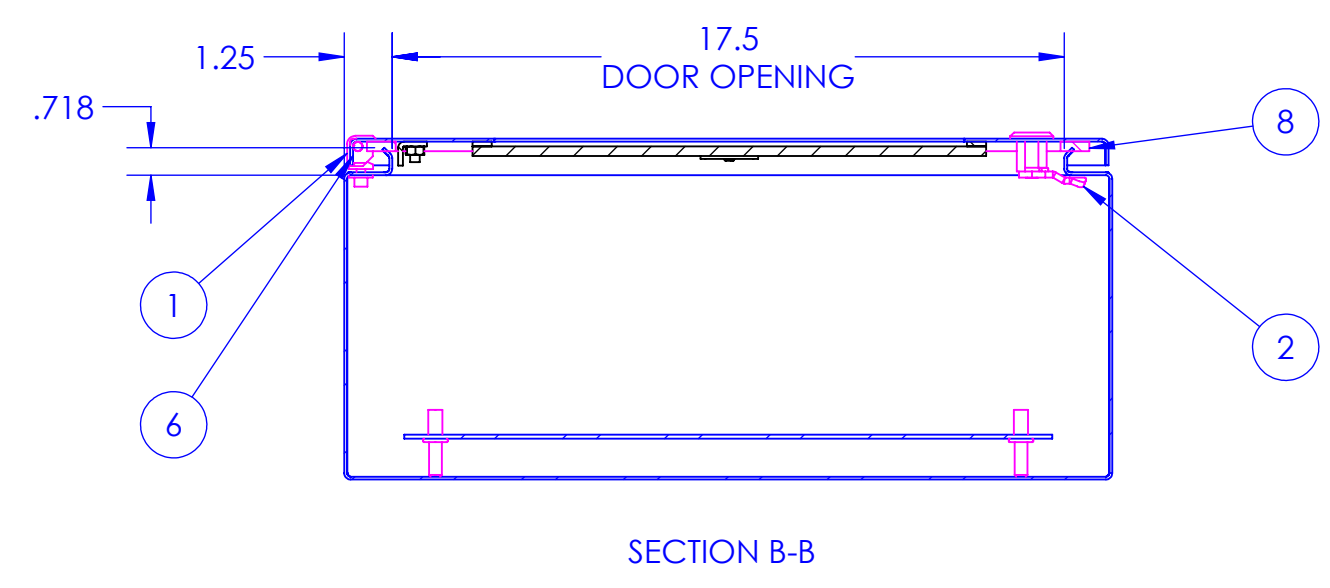
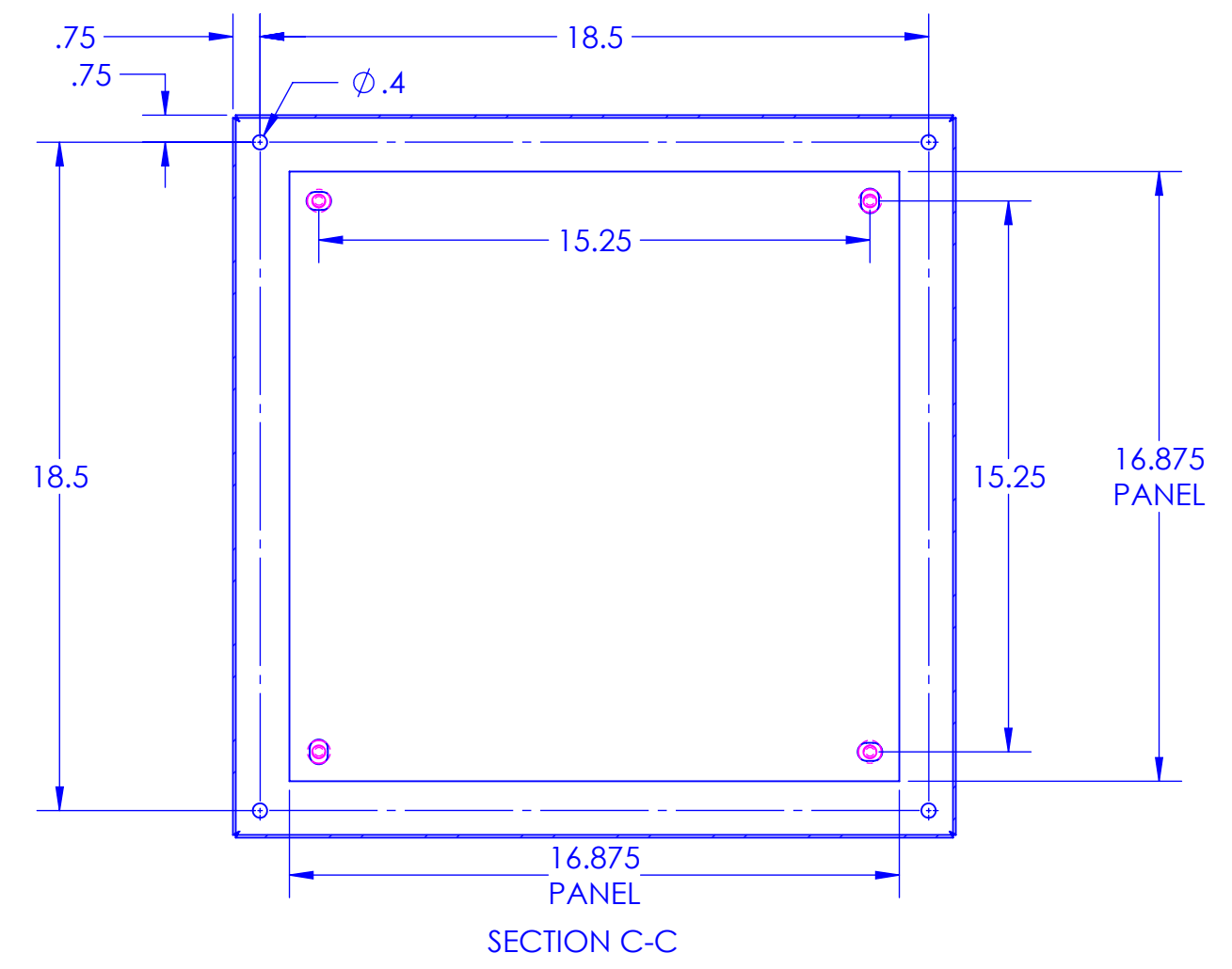
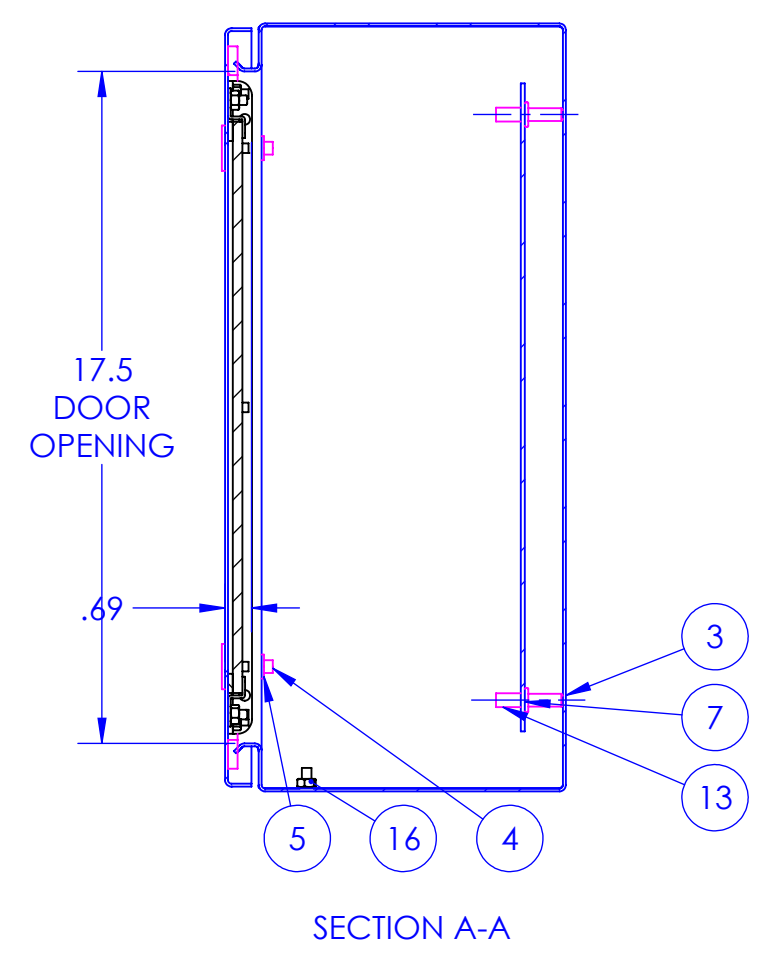
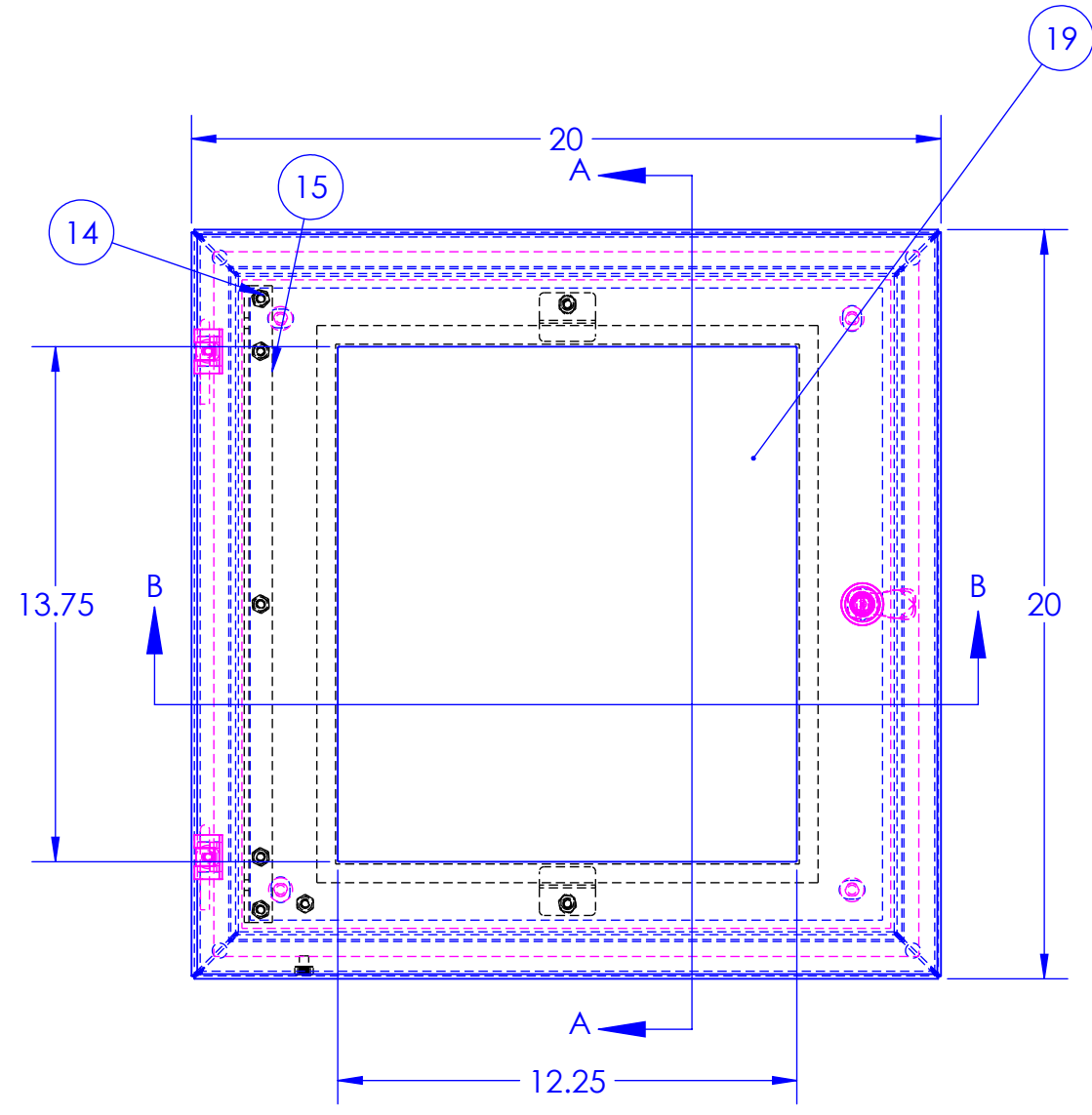
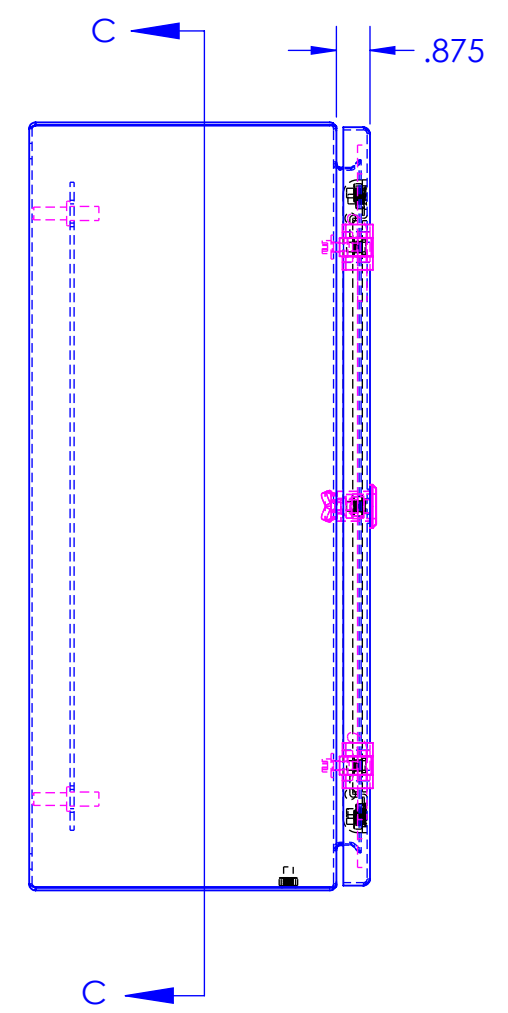
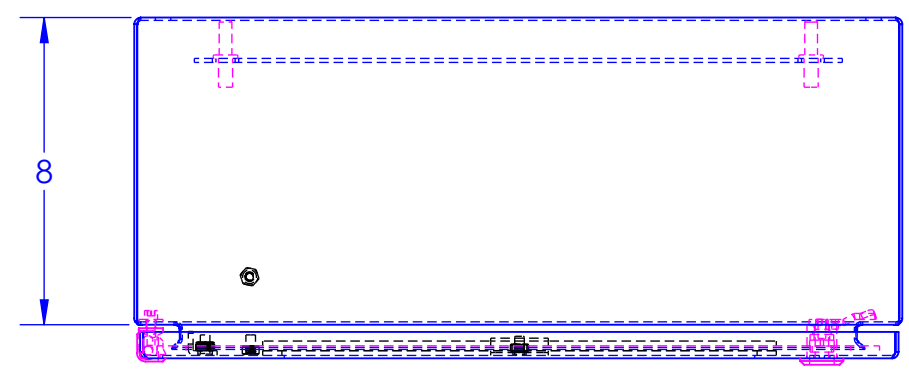
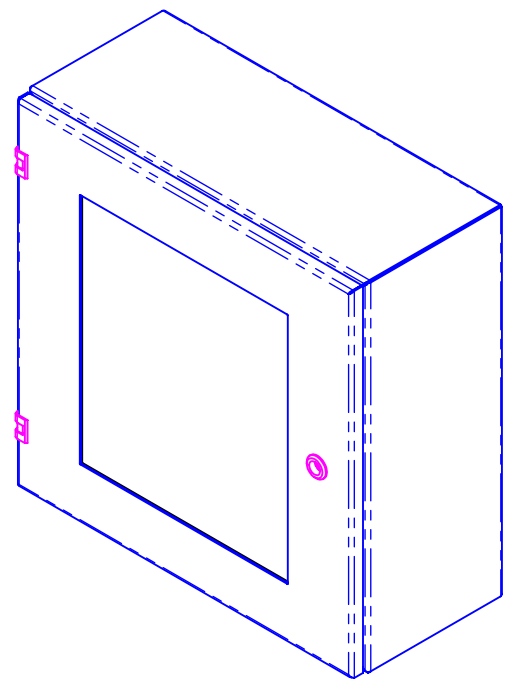

<b>PROPRIETARY AND CONFIDENTIAL</b> THE INFORMATION CONTAINED IN THIS DRAWING IS THE SOLE PROPERTY OF RALSTON METAL PRODUCTS. ANY REPRODUCTION IN PART OR AS A WHOLE WITHOUT THE WRITTEN PERMISSION OF RALSTON METAL PRODUCTS IS PROHIBITED.  UNLESS OTHERWISE SPECIFIED DIMENSIONS ARE IN INCHES TOLERANCES: FRACTIONAL ± 1/32" ANGULAR ± .001" ONE PLACE DECIMAL ± 0.1" TWO PLACE DECIMAL ± 0.01" THREE PLACE DECIMAL ± 0.002" MATERIAL: SEE BOM FINISH: SEE BOM DO NOT SCALE DRAWING	NAME: DAVE BURNS DATE: 2023-03-02 ISSUED BY: DAVE BURNS 2023-03-02 JOB ORDER NO:	88 WATSON ROAD QUELPS, ONTARIO N1L 1E2 PHONE: (519) 836-2969 TOLL FREE: 1-800-265-7611 FAX: (519) 836-9793 <b>Ralston</b> Metal Products Limited www.RALSTONMETAL.COM
	CUSTOMER DRAWING NO:  (AUTHORIZED SIGNATURE IN RED) 	CUSTOMER: RALSTON STOCK SHOP DRAWING NUMBER:  SIZE: C PART NAME: V-SW-202008 PART NO.: V-SW-202008 WEIGHT: 42.902 SHEET 1 OF 1