

4

3

2

1

REVISIONS			
REV.	DESCRIPTION	DATE	APPROVED

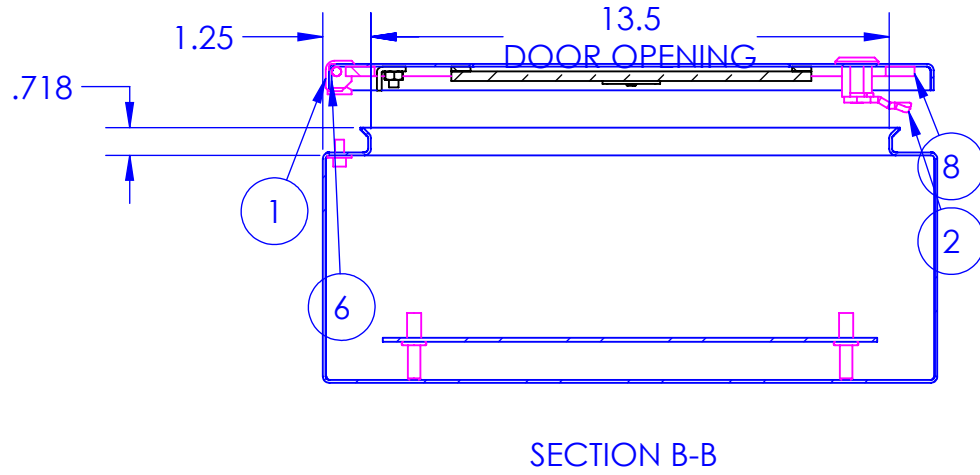
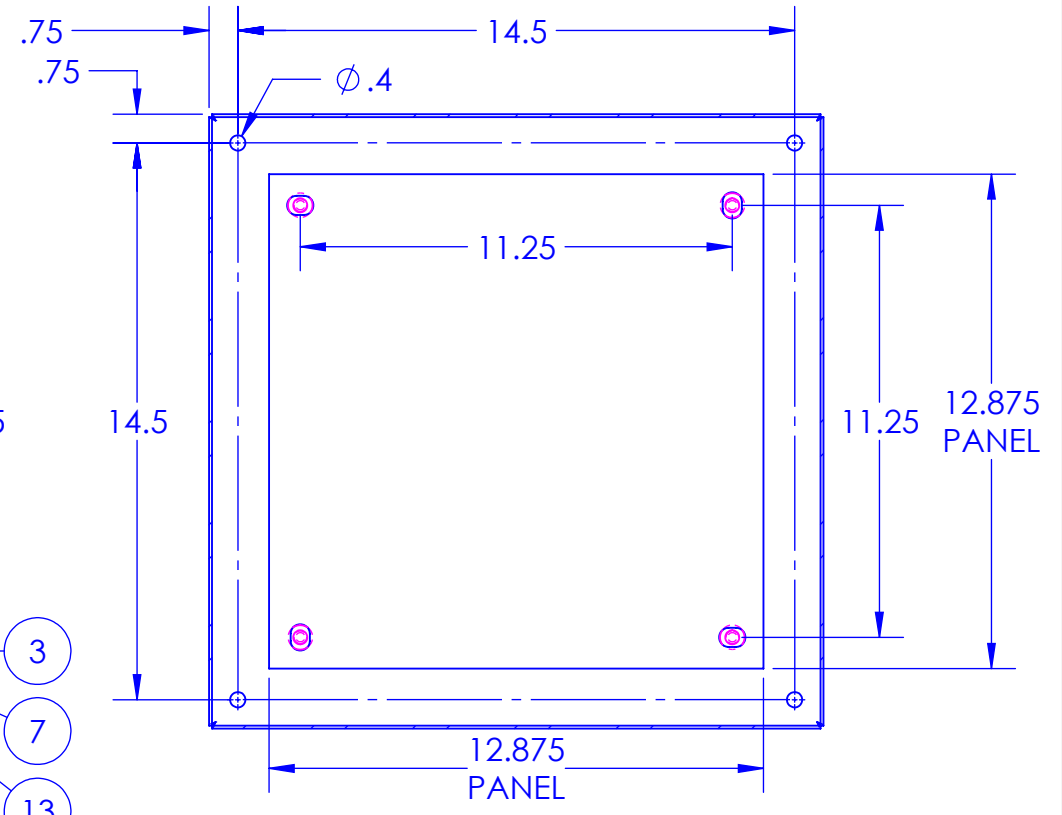
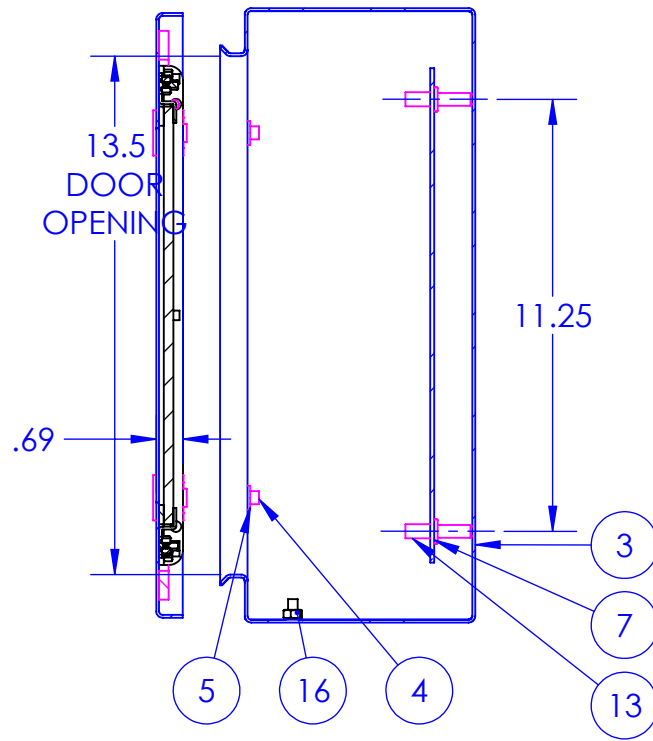
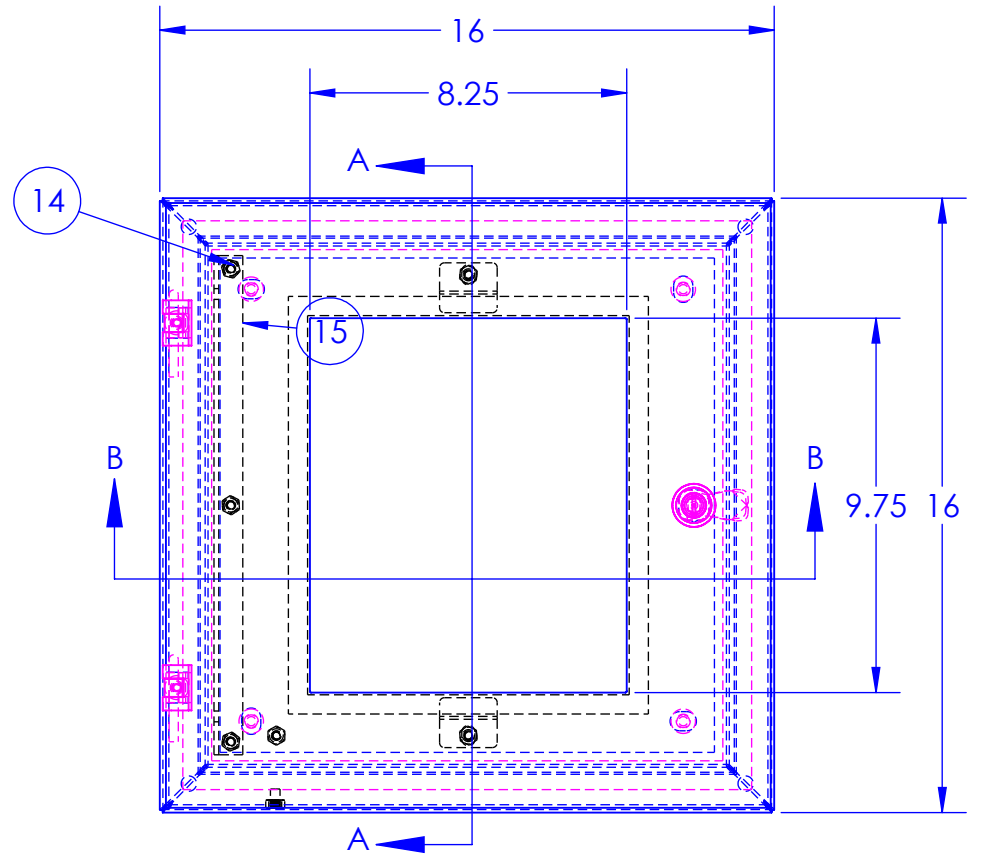
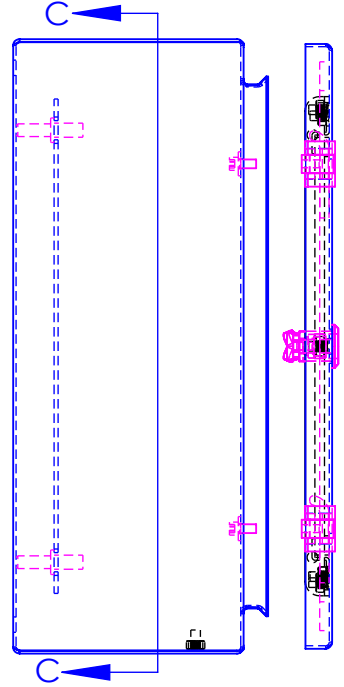
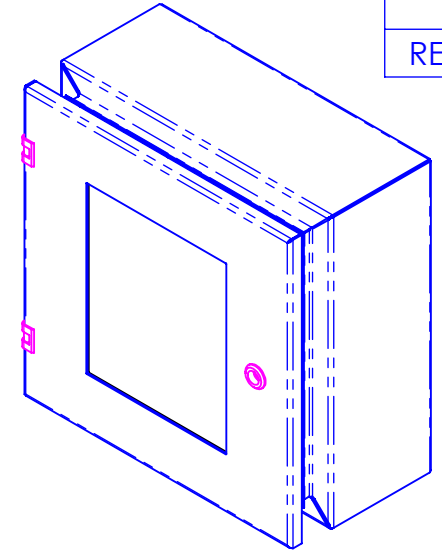
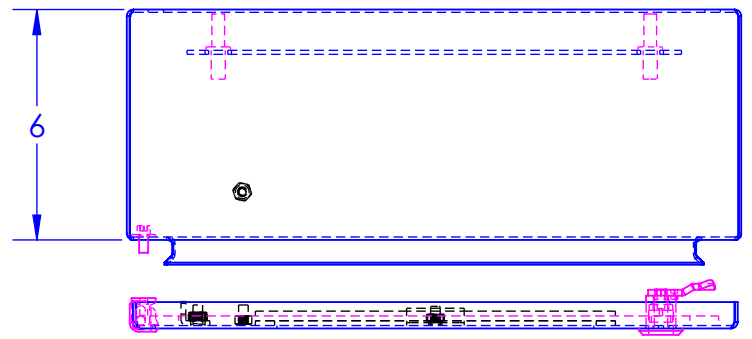

**PROPRIETARY AND CONFIDENTIAL**  
 THE INFORMATION CONTAINED IN THIS DRAWING IS THE SOLE PROPERTY OF RALSTON METAL PRODUCTS. ANY REPRODUCTION IN PART OR AS A WHOLE WITHOUT THE WRITTEN PERMISSION OF RALSTON METAL PRODUCTS IS PROHIBITED.

**UNLESS OTHERWISE SPECIFIED**  
 DIMENSIONS ARE IN INCHES  
 TOLERANCES:  
 FRACTIONAL ±1/32"  
 ANGULAR: MACH ±1° BEND ±1/32"  
 ONE PLACE DECIMAL ±0.1"  
 TWO PLACE DECIMAL ±0.01"  
 THREE PLACE DECIMAL ±0.005"

MATERIAL:  
 SEE BOM

FINISH:  
 SEE BOM

DO NOT SCALE DRAWING

NAME	DATE
DRAWN BY DAVE BURNS	2023-03-02
ISSUED BY DAVE BURNS	2023-03-02
JOB ORDER NO:	
CUSTOMER DRAWING NO:	

(AUTHORIZED SIGNATURE IN RED)

THIRD ANGLE PROJECTION

50 Watson Road  
 Guelph, Ontario N1L 1E2  
 Phone: (519) 836-2968  
 Toll Free: 1-800-265-7611  
 Fax: (519) 836-9763  
 www.ralstonmetal.com

**Ralston**  
 Metal Products Limited

CUSTOMER:  
**RALSTON STOCK**  
 SHOP DRAWING NUMBER:

SIZE	PART NAME:	REV.
<b>B</b>	<b>V-SW-161606</b>	
PART NO.	V-SW-161606	
SCALE: 1:5	WEIGHT: 27.475	SHEET 1 OF 1

4

3

2

1

B

B

A

A