

4

3

2

1

REVISIONS			
REV.	DESCRIPTION	DATE	APPROVED

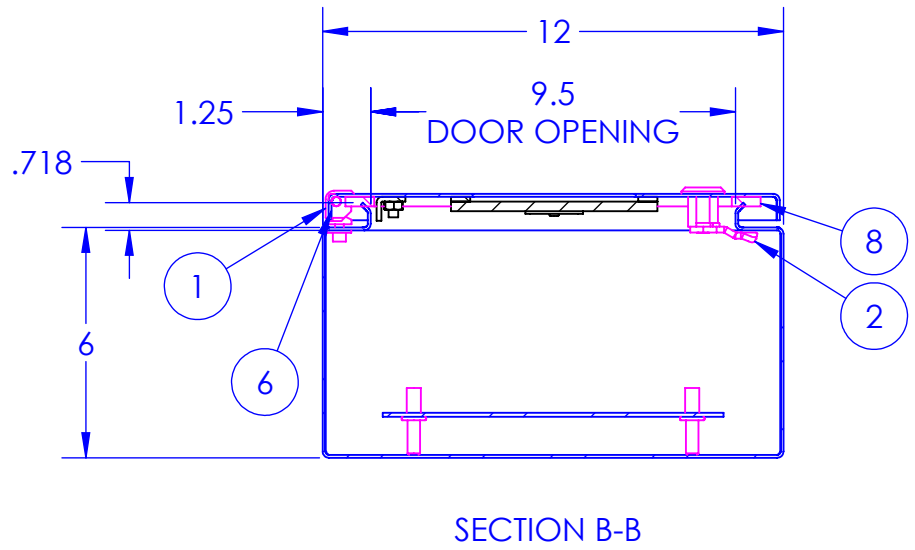
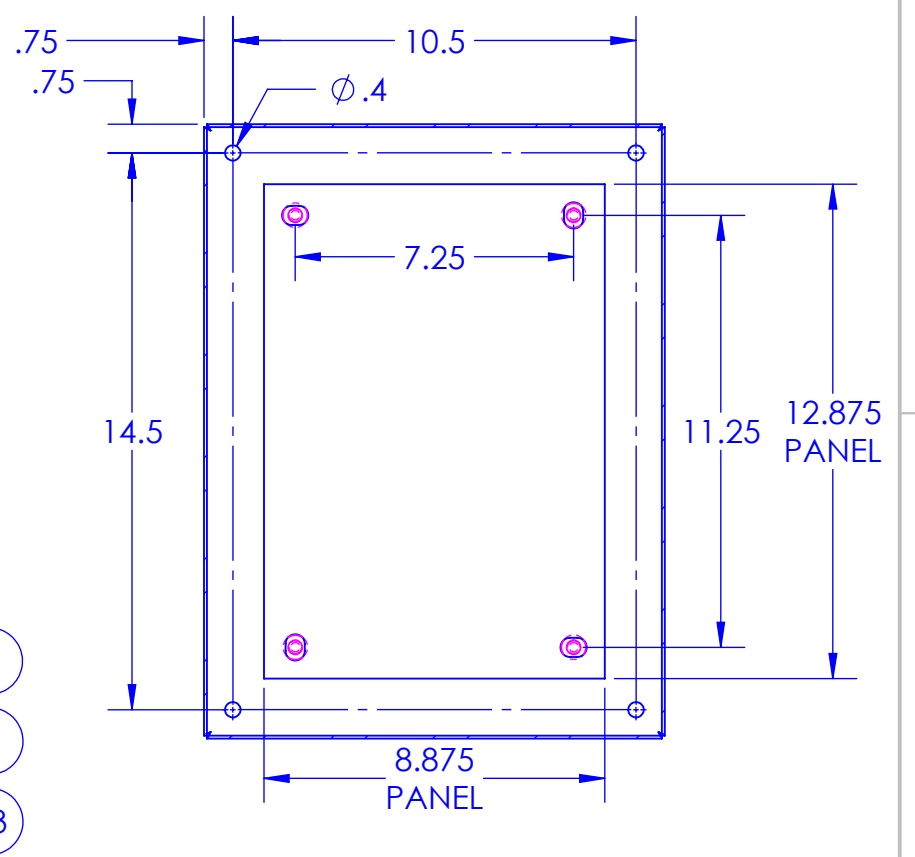
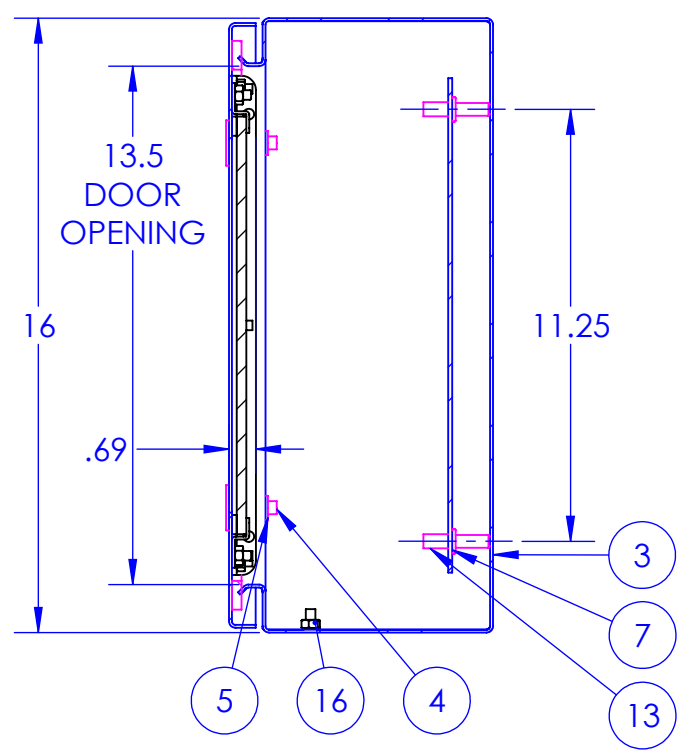
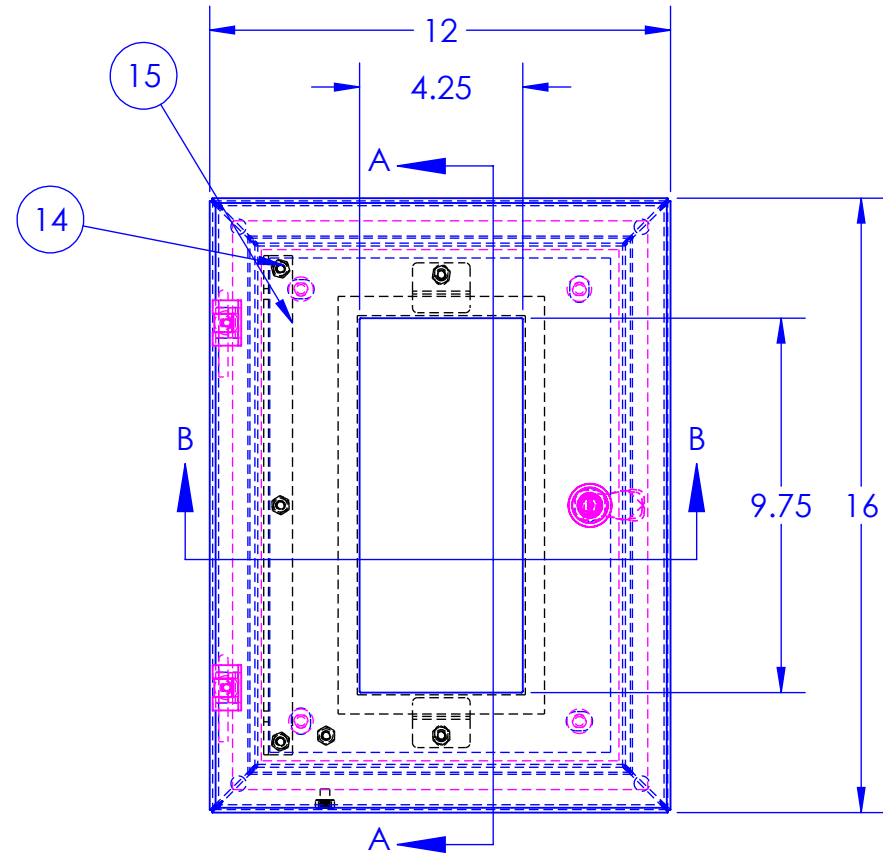
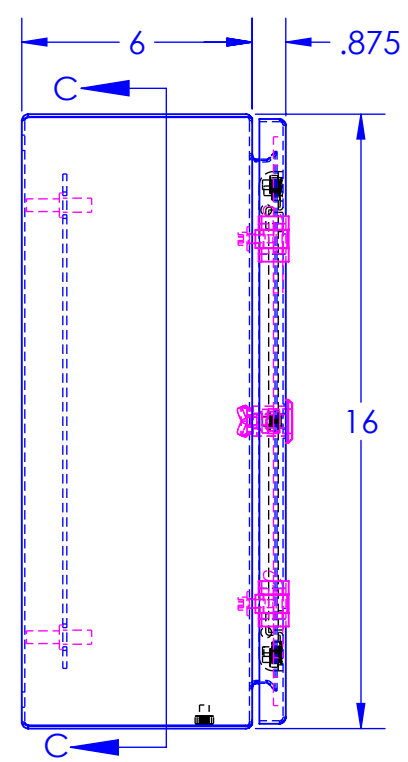
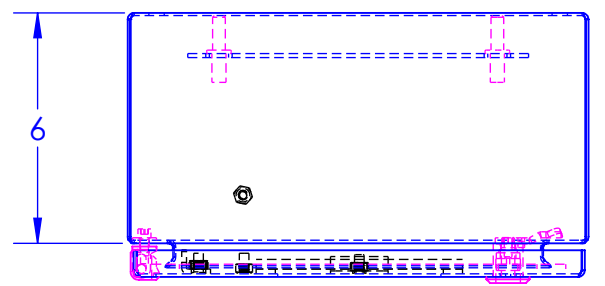
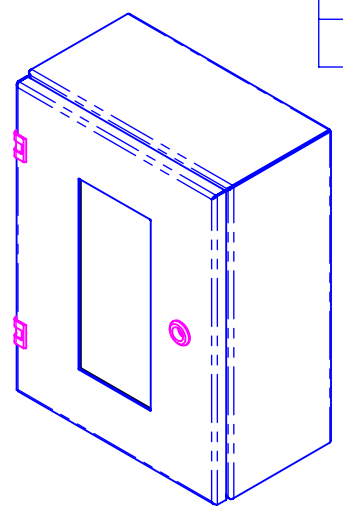

SECTION A-A

SECTION C-C

SECTION B-B

PROPRIETARY AND CONFIDENTIAL THE INFORMATION CONTAINED IN THIS DRAWING IS THE SOLE PROPERTY OF RALSTON METAL PRODUCTS. ANY REPRODUCTION IN PART OR AS A WHOLE WITHOUT THE WRITTEN PERMISSION OF RALSTON METAL PRODUCTS IS PROHIBITED.	DRAWN BY	DAVE BURNS	DATE	2023-03-02
	ISSUED BY	DAVE BURNS	DATE	2023-03-02
UNLESS OTHERWISE SPECIFIED DIMENSIONS ARE IN INCHES TOLERANCES: FRACTIONAL: ±1/32" ANGULAR: MACH ±1° BEND ±1/32" ONE PLACE DECIMAL ±0.1" TWO PLACE DECIMAL ±0.01" THREE PLACE DECIMAL ±0.005" MATERIAL:	JOB ORDER NO:			
	CUSTOMER DRAWING NO:			
SEE BOM	(AUTHORIZED SIGNATURE IN RED) 			
SEE BOM				
DO NOT SCALE DRAWING	THIRD ANGLE PROJECTION	SCALE: 1:5	WEIGHT: 22.095	SHEET 1 OF 1

50 Watson Road
Guelph, Ontario N1L 1E2
Phone: (519) 836-2968
Toll Free: 1-800-265-7611
Fax: (519) 836-9763
www.ralstonmetal.com

RALSTON STOCK

SHOP DRAWING NUMBER:

SIZE: **B** PART NAME: **V-SW-161206** REV.:

PART NO. **V-SW-161206**

4

3

2

1