

4

3

2

1

REVISIONS			
REV.	DESCRIPTION	DATE	APPROVED

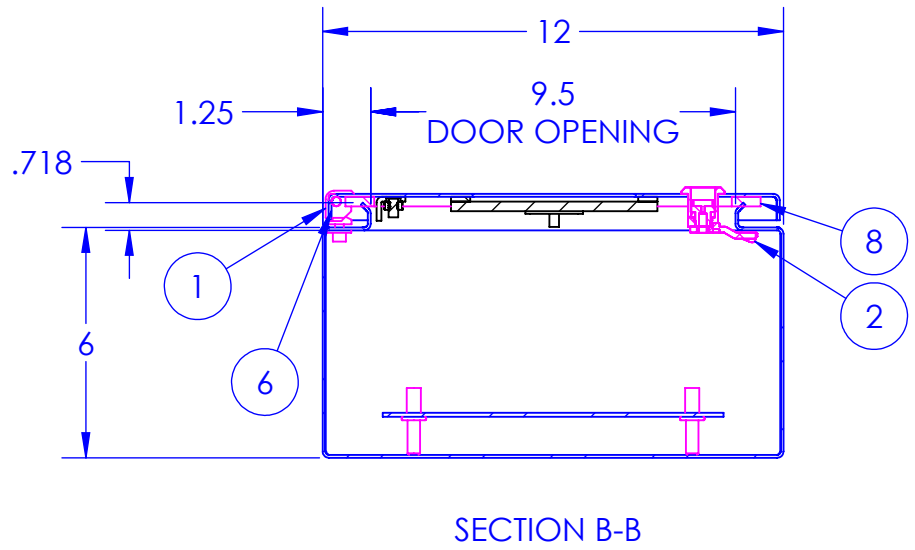
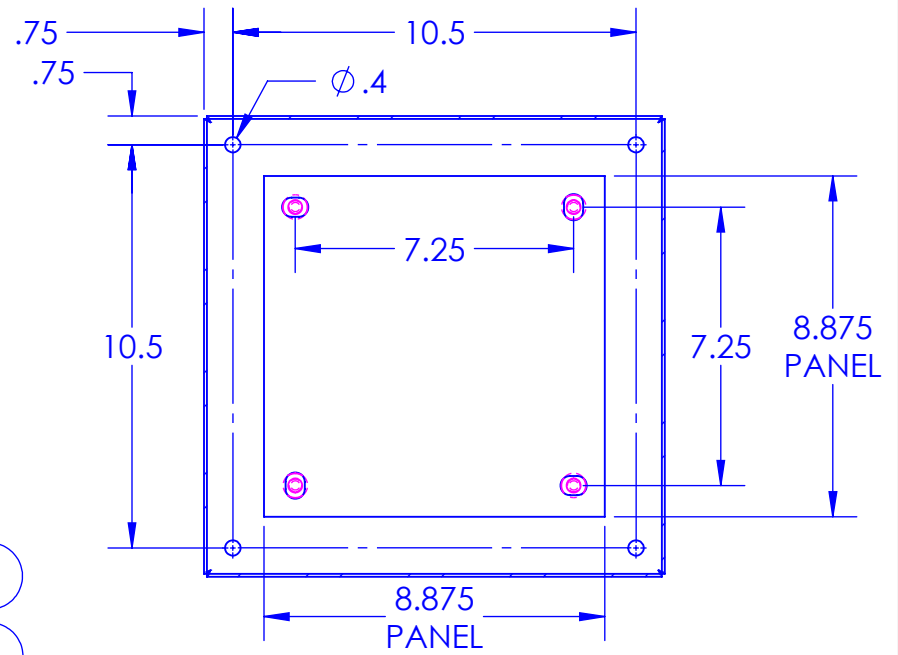
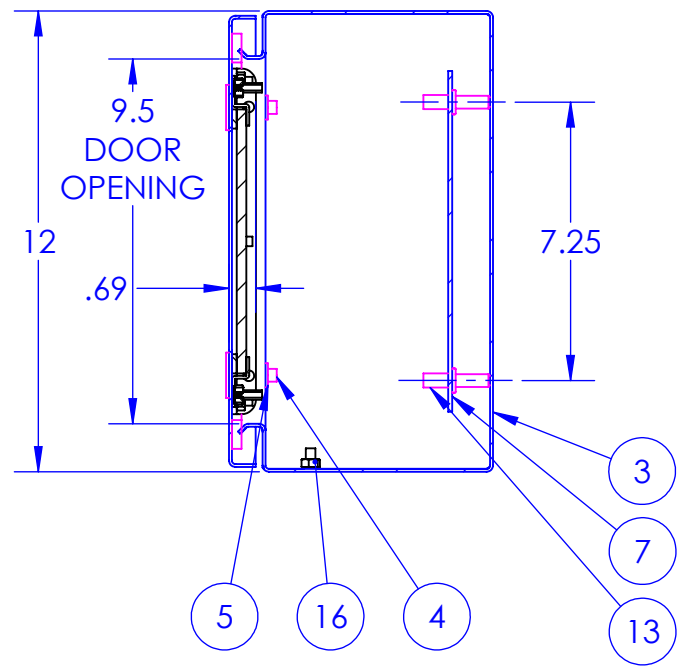
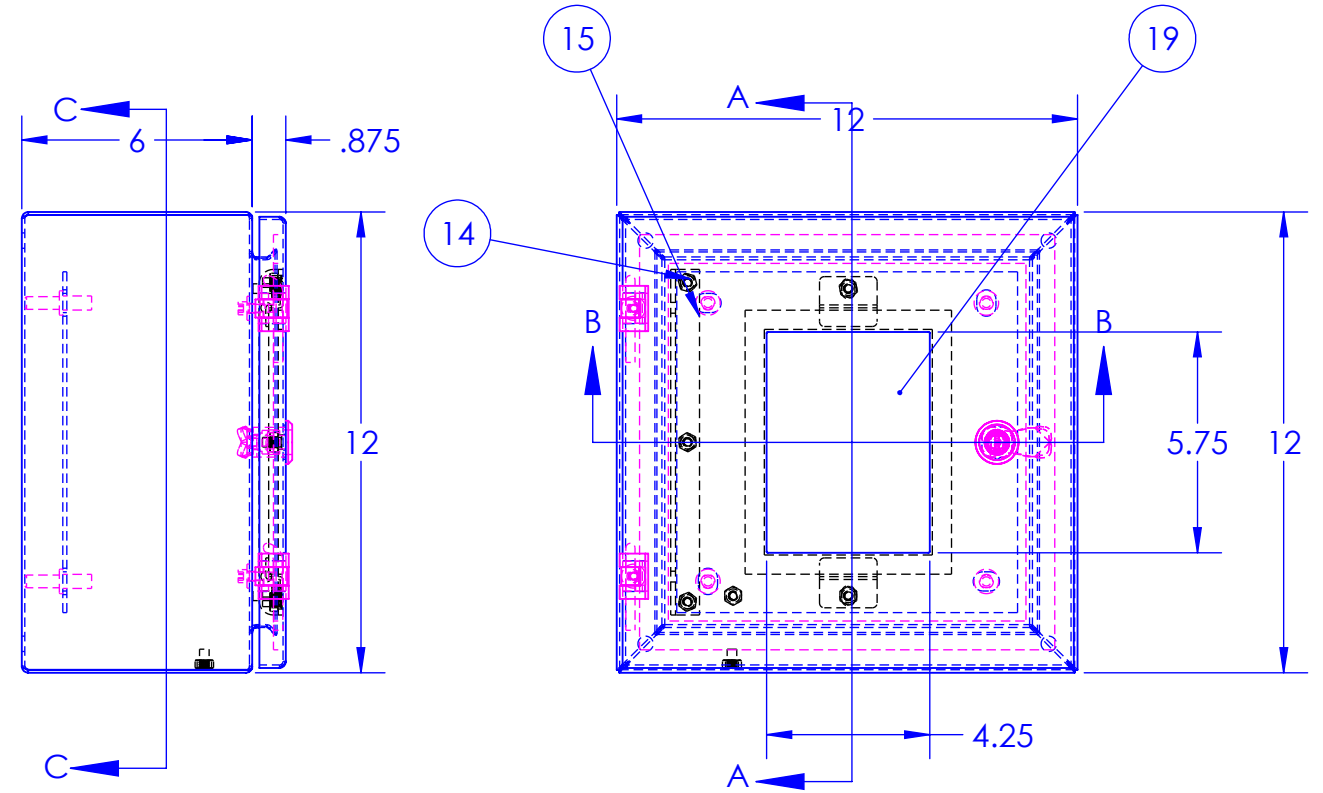
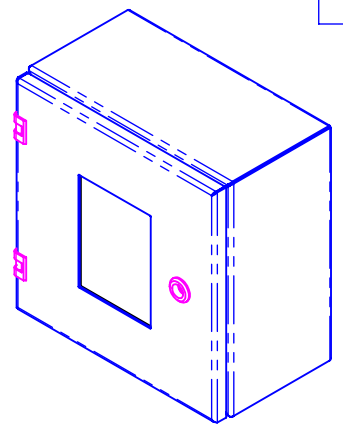
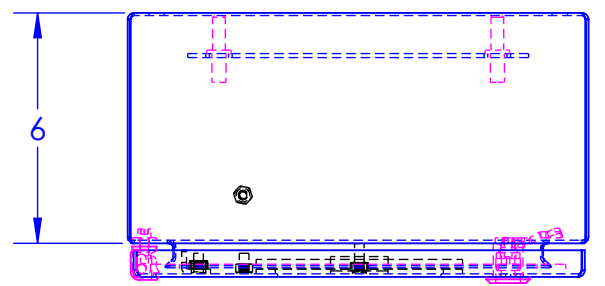

PROPRIETARY AND CONFIDENTIAL
 THE INFORMATION CONTAINED IN THIS DRAWING IS THE SOLE PROPERTY OF RALSTON METAL PRODUCTS. ANY REPRODUCTION IN PART OR AS A WHOLE WITHOUT THE WRITTEN PERMISSION OF RALSTON METAL PRODUCTS IS PROHIBITED.

UNLESS OTHERWISE SPECIFIED
 DIMENSIONS ARE IN INCHES
 TOLERANCES:
 FRACTIONAL ±1/32"
 ANGULAR: MACH ±1° BEND ±1/32"
 ONE PLACE DECIMAL ±0.1"
 TWO PLACE DECIMAL ±0.01"
 THREE PLACE DECIMAL ±0.005"

MATERIAL:
 SEE BOM
 FINISH:
 SEE BOM
 DO NOT SCALE DRAWING

NAME	DATE
DRAWN BY DAVE BURNS	2023-03-02
ISSUED BY DAVE BURNS	2023-03-02
JOB ORDER NO:	
CUSTOMER DRAWING NO:	

(AUTHORIZED SIGNATURE IN RED)

THIRD ANGLE PROJECTION

50 Watson Road
 Guelph, Ontario N1L 1E2
 Phone: (519) 836-2968
 Toll Free: 1-800-265-7611
 Fax: (519) 836-9763
www.ralstonmetal.com

Ralston
 Metal Products Limited

CUSTOMER:
RALSTON STOCK
 SHOP DRAWING NUMBER:

SIZE	PART NAME	REV.
B	V-SW-121206	

PART NO. V-SW-121206
 SCALE: 1:5 WEIGHT: 17.475 SHEET 1 OF 1

4

3

2

1

B

B

A

A