

REVISIONS			
REV.	DESCRIPTION	DATE	APPROVED

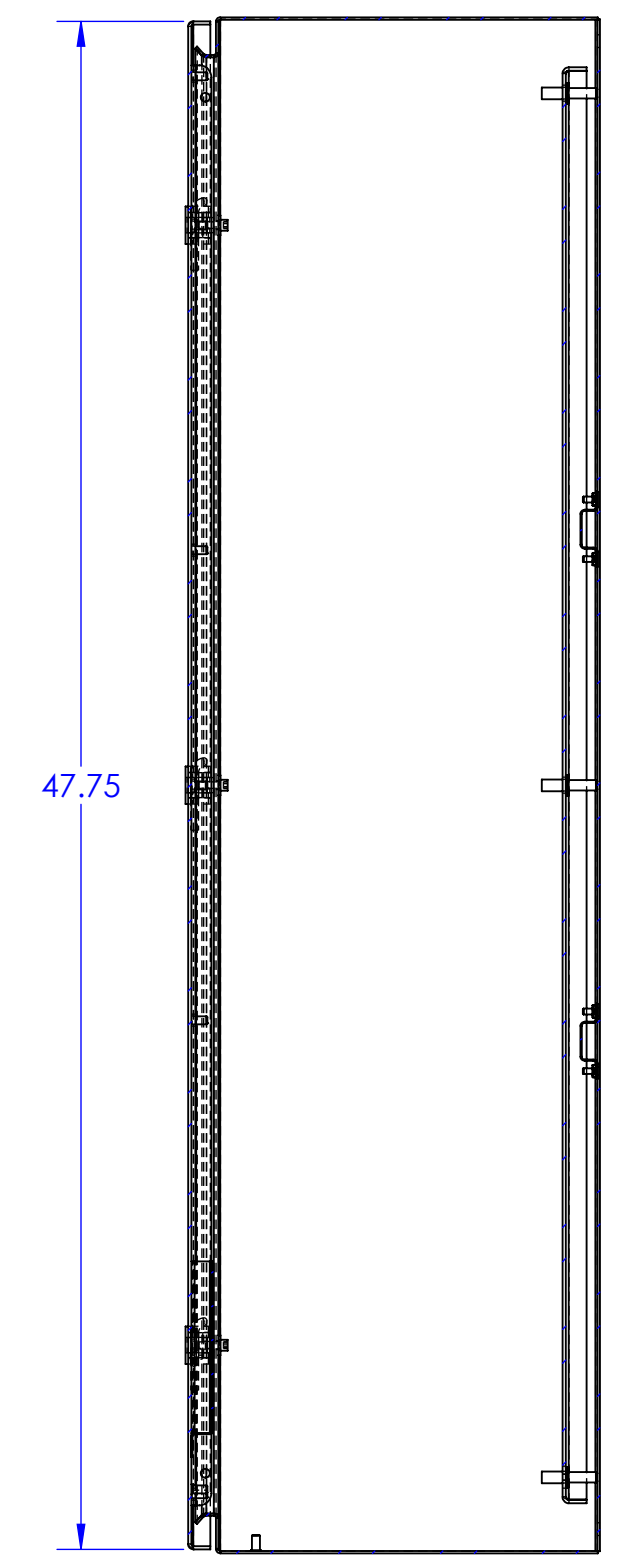

SECTION A-A

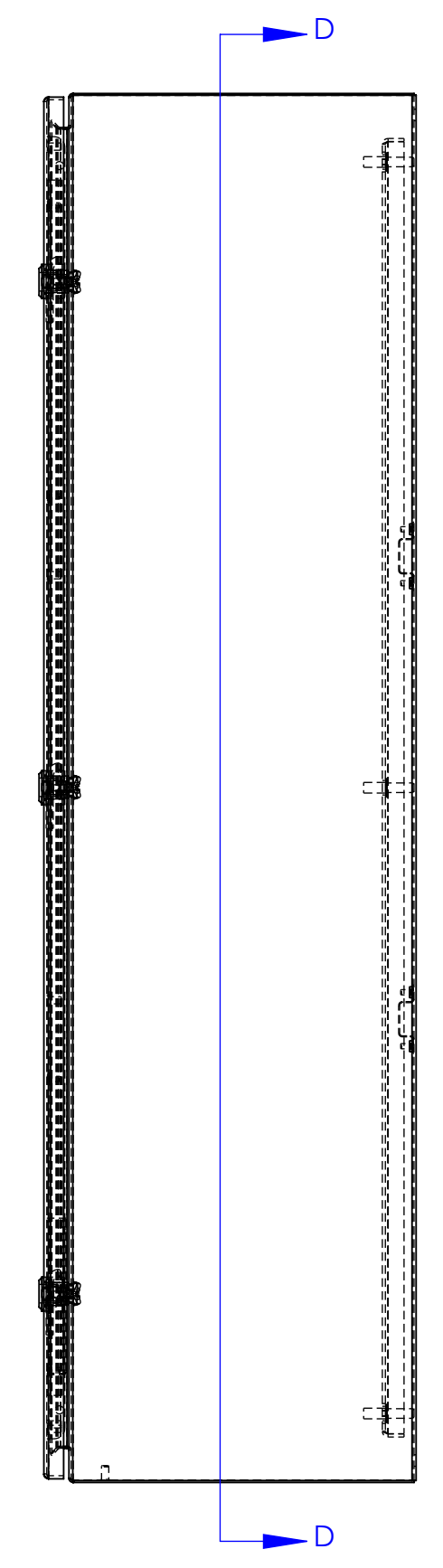
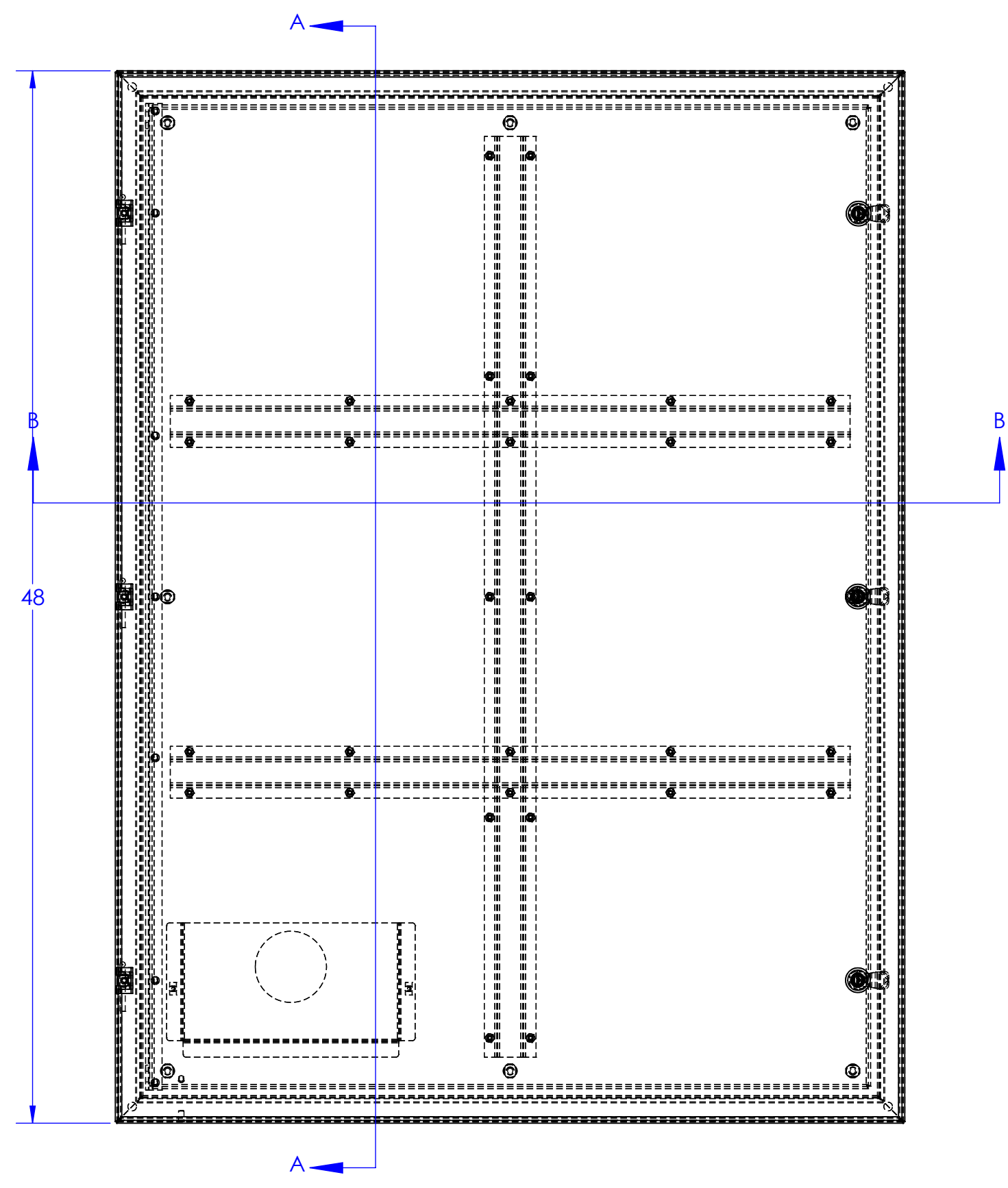
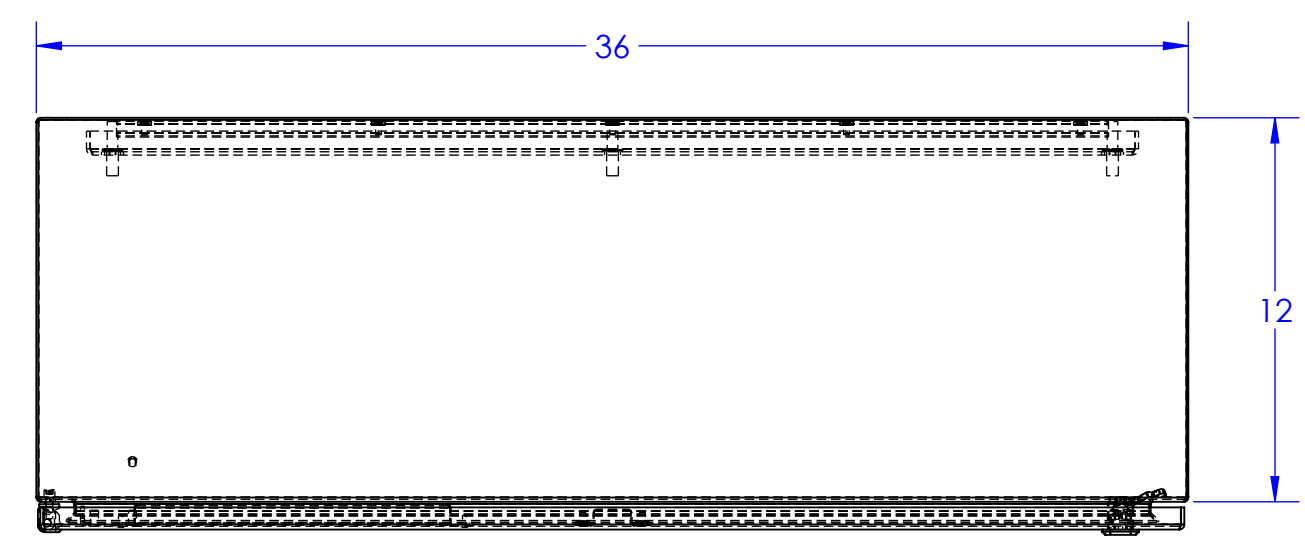
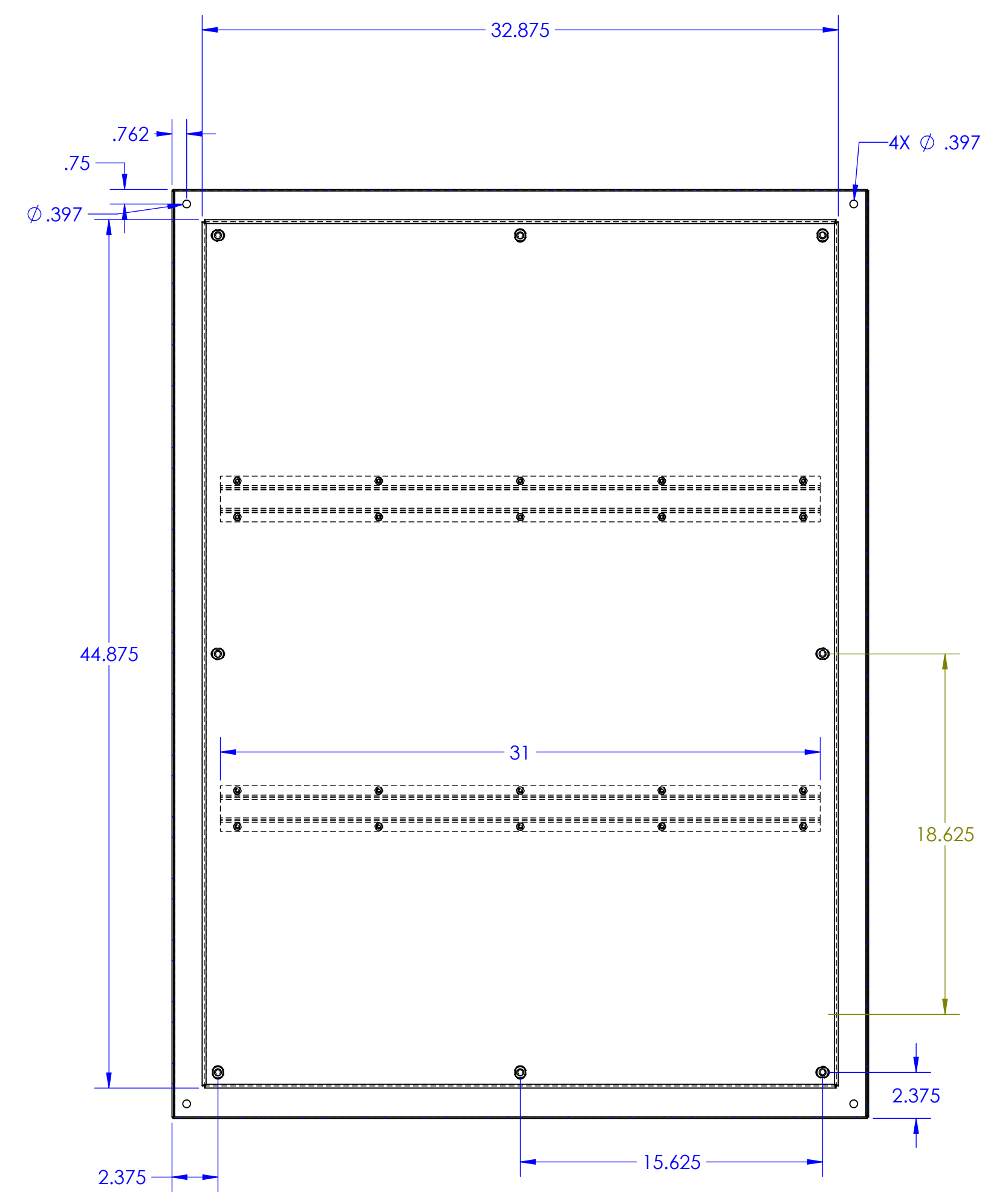

SECTION D-D

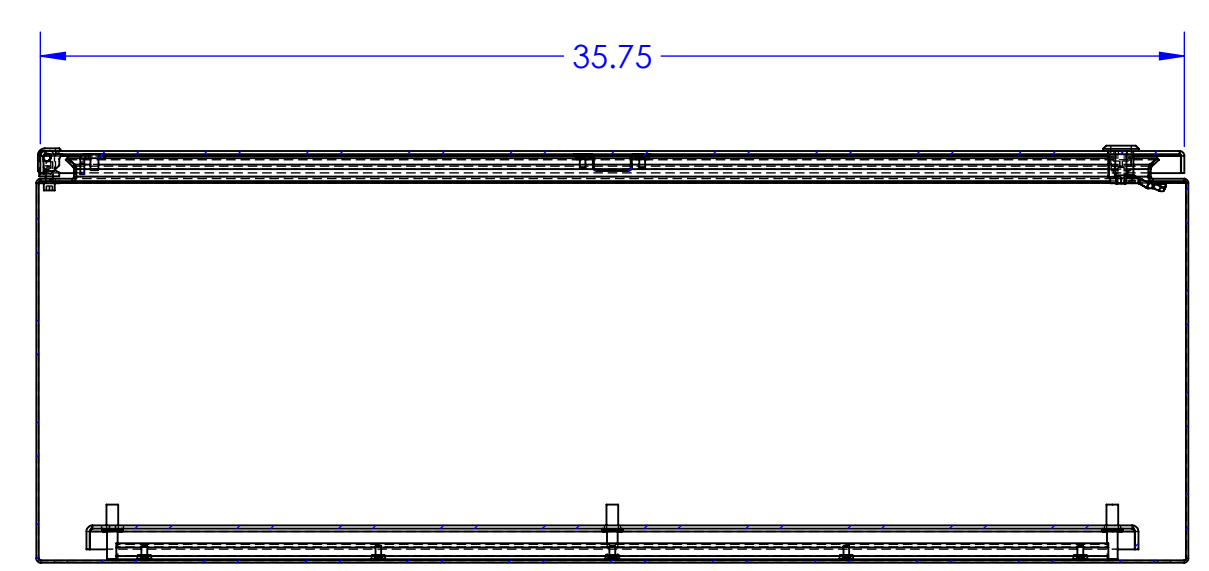

SECTION B-B

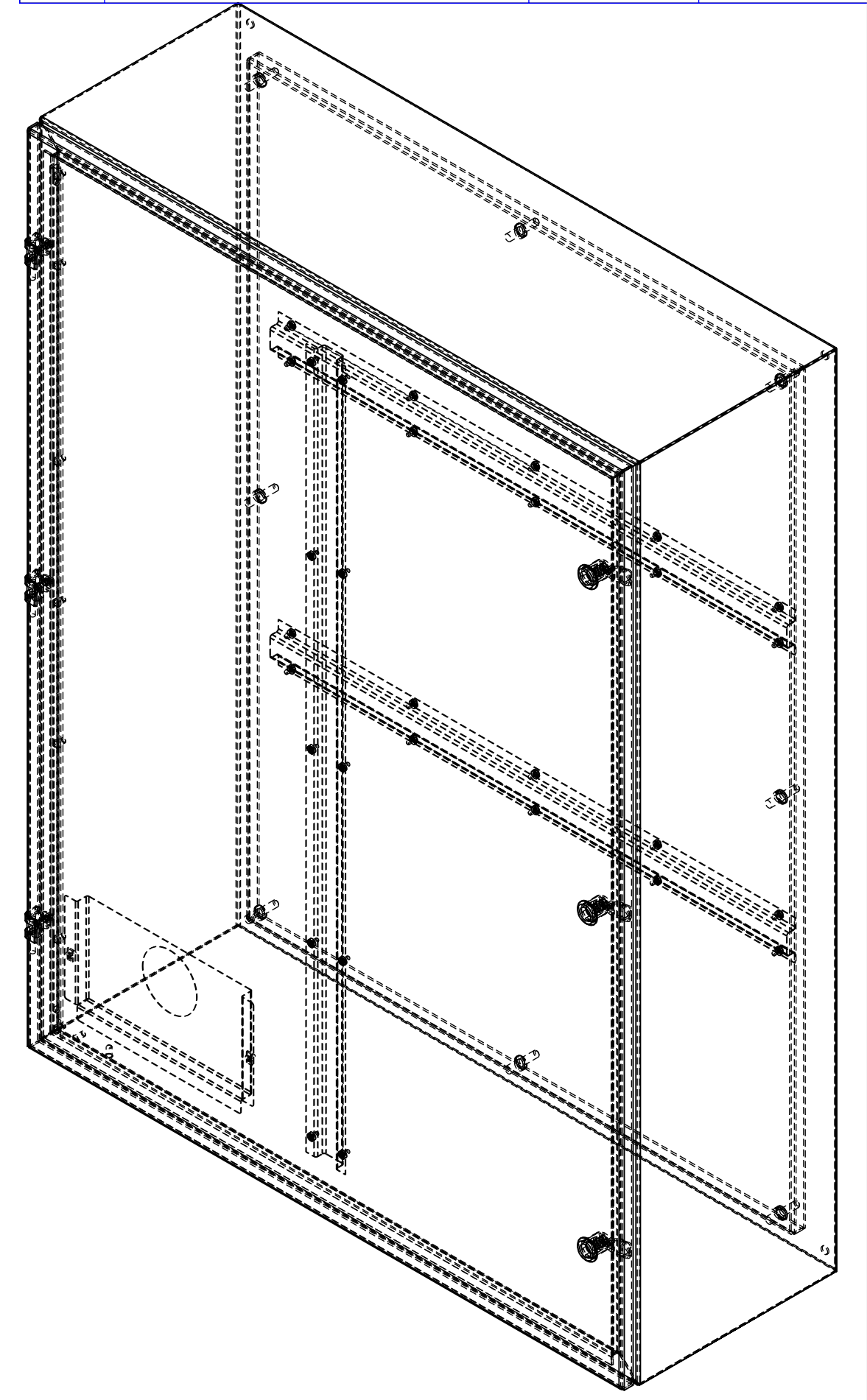

PROPRIETARY AND CONFIDENTIAL		NAME	DATE		15 RALSTON ROAD GUILDFORD ONTARIO N4L 1B2 PHONE: (519) 848-0888 TOLL FREE: 1-800-365-7611 FAX: (519) 848-0891 WWW.RALSTONMETAL.COM
THE INFORMATION CONTAINED IN THIS DRAWING IS THE SOLE PROPERTY OF RALSTON METAL PRODUCTS. ANY REPRODUCTION IN PART OR AS A WHOLE WITHOUT THE WRITTEN PERMISSION OF RALSTON METAL PRODUCTS IS PROHIBITED.		DRAWN BY	WAYNE STINODT		1/25/2023
UNLESS OTHERWISE SPECIFIED: DIMENSIONS ARE IN INCHES TOLERANCES: FRACTIONS: ±1/32" ANGULAR: MATCH 11° ±1/2° ONE PLACE DECIMAL ±.01" TWO PLACE DECIMAL ±.005" SURFACE FINISH: PER SPEC		ISSUED BY	WAYNE STINODT	1/25/2023	RALSTON STOCK PART NO. V-SS-423612 V-SS-483612 ASSEMBLY SCALE: 1:4 WEIGHT: 191.777 SHEET 1 OF 1
SEE BOM FRST: SEE BOM DO NOT SCALE DRAWING		JOB ORDER NO.:			SEE BOM FRST: SEE BOM DO NOT SCALE DRAWING