

REVISIONS			
REV.	DESCRIPTION	DATE	APPROVED

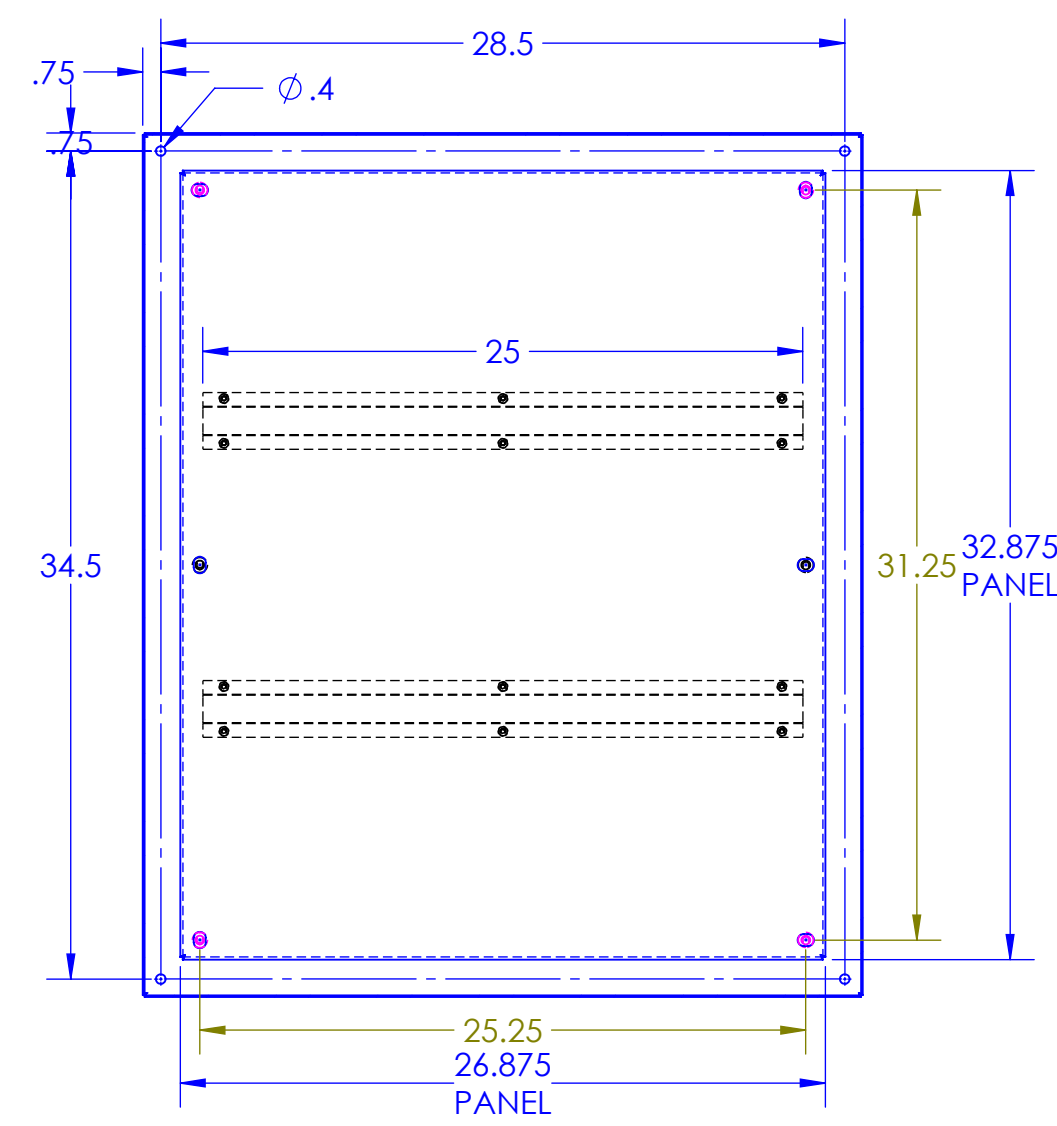

SECTION C-C

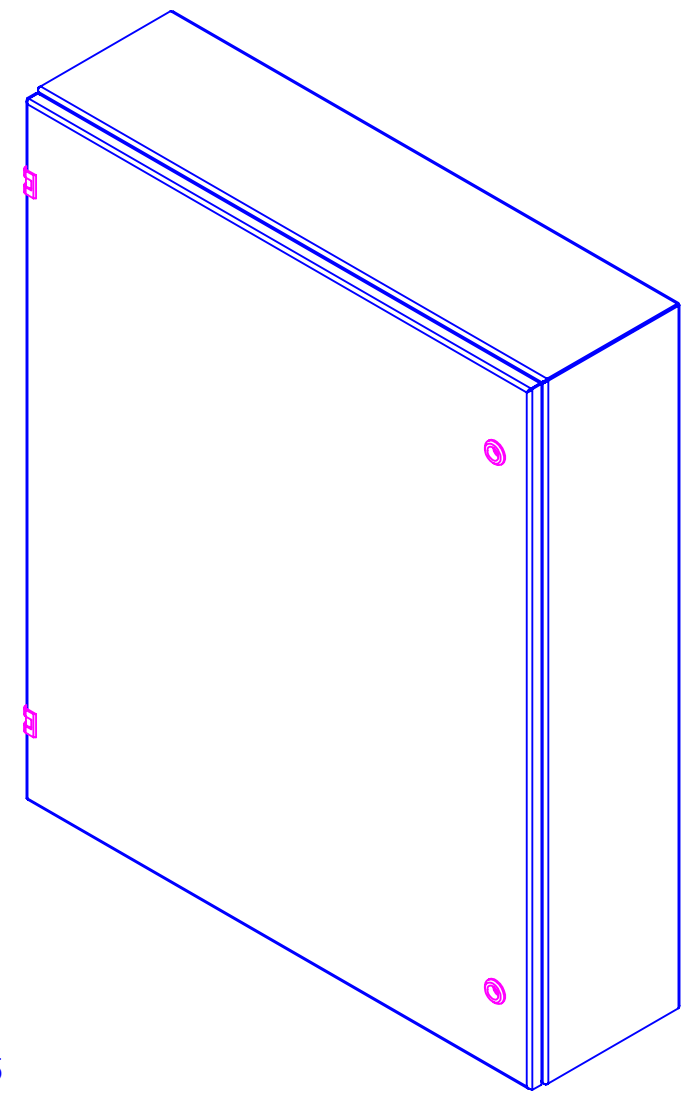
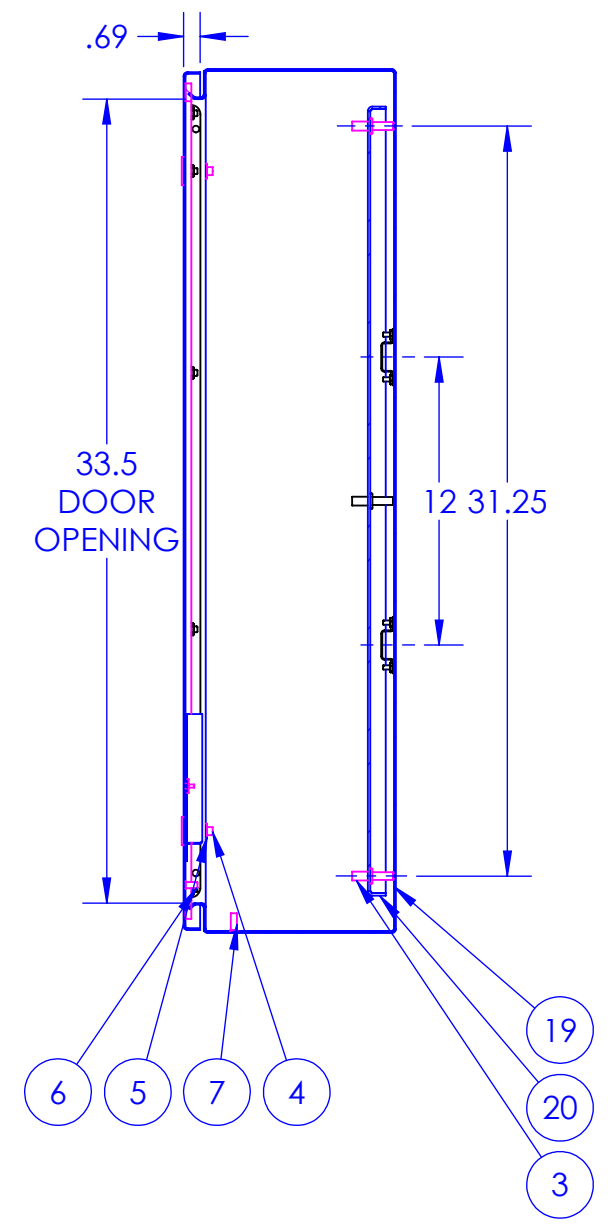

SECTION A-A

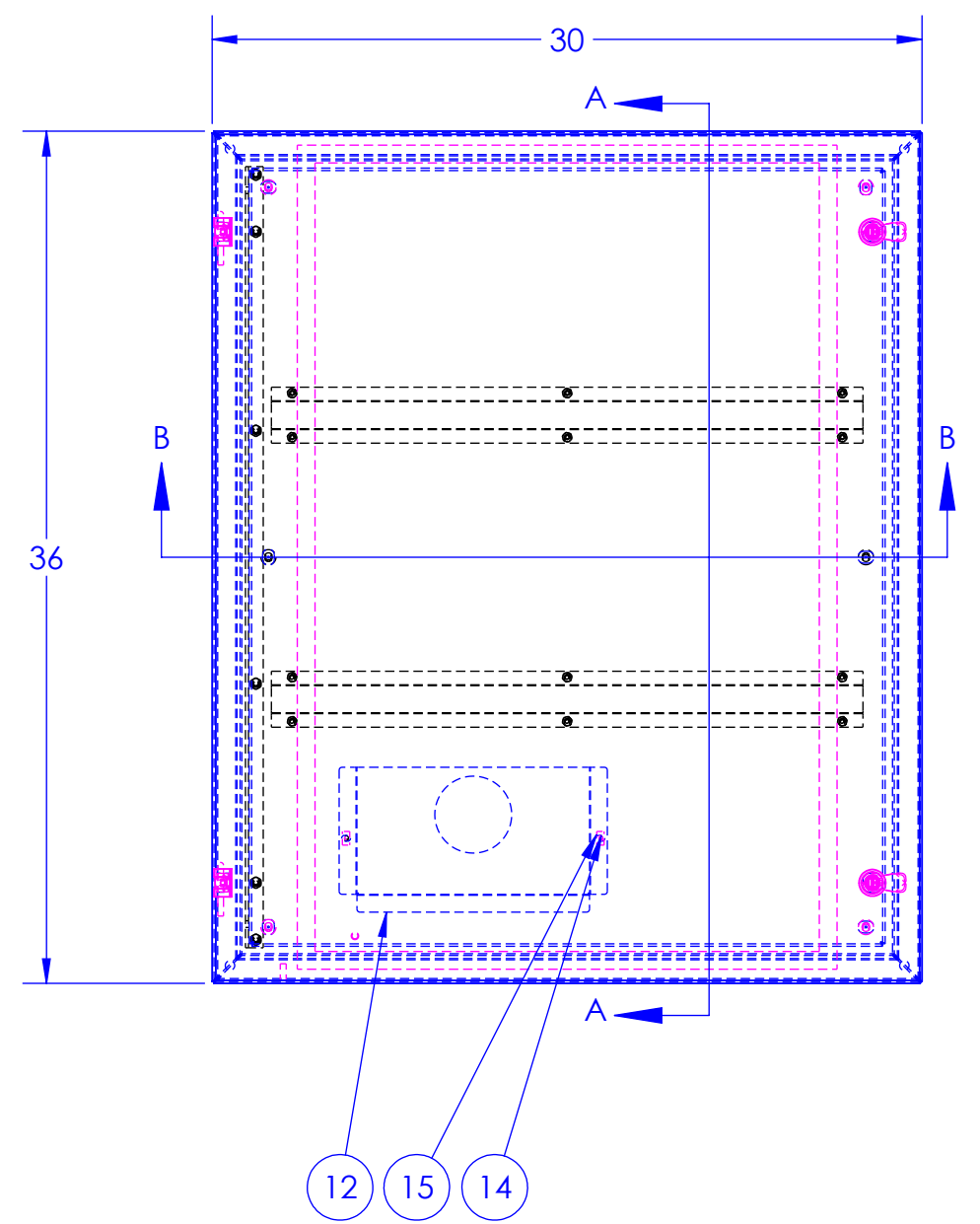

SECTION B-B

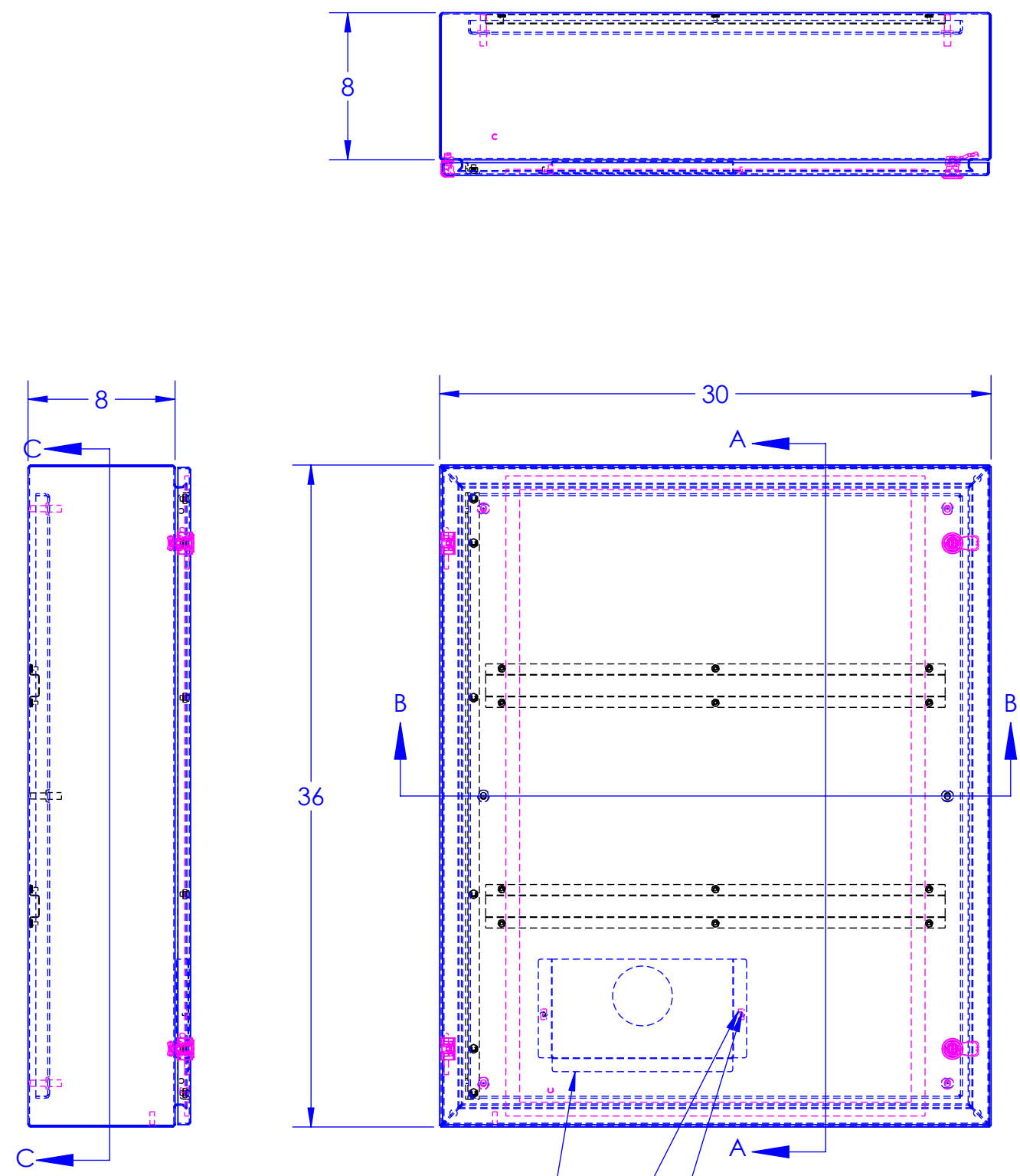

PROPRIETARY AND CONFIDENTIAL THE INFORMATION CONTAINED IN THIS DRAWING IS THE SOLE PROPERTY OF RALSTON METAL PRODUCTS. ANY REPRODUCTION IN PART OR AS A WHOLE WITHOUT THE WRITTEN PERMISSION OF RALSTON METAL PRODUCTS IS PROHIBITED.		NAME	DATE		55 WATSON ROAD QUELUP, ONTARIO N1L 1E2 PHONE: (519) 836-2969 TOLL FREE: 1-800-265-7611 FAX: (519) 836-9793
<small>TOLERANCES: DIMENSIONS ARE IN INCHES FRACTIONAL ±1/32" ANGULAR MACH ±1° ONE PLACE DECIMAL ±0.1" TWO PLACE DECIMAL ±0.01" THREE PLACE DECIMAL ±0.005"</small>		DRAWN BY	ISSUED BY		CUSTOMER:
<small>UNLESS OTHERWISE SPECIFIED</small> FINISH: SEE BOM DO NOT SCALE DRAWING		CUSTOMER DRAWING NO: SHOP ORDER NO:		SHOP DRAWING NUMBER:	SIZE PART NAME: REV. C ASSEMBLY
		(AUTHORIZED SIGNATURE IN RED) 		PART NO. V-SS-363008 SCALE: 1:8 WEIGHT: 108.026 SHEET 1 OF 1	