

REVISIONS			
REV.	DESCRIPTION	DATE	APPROVED

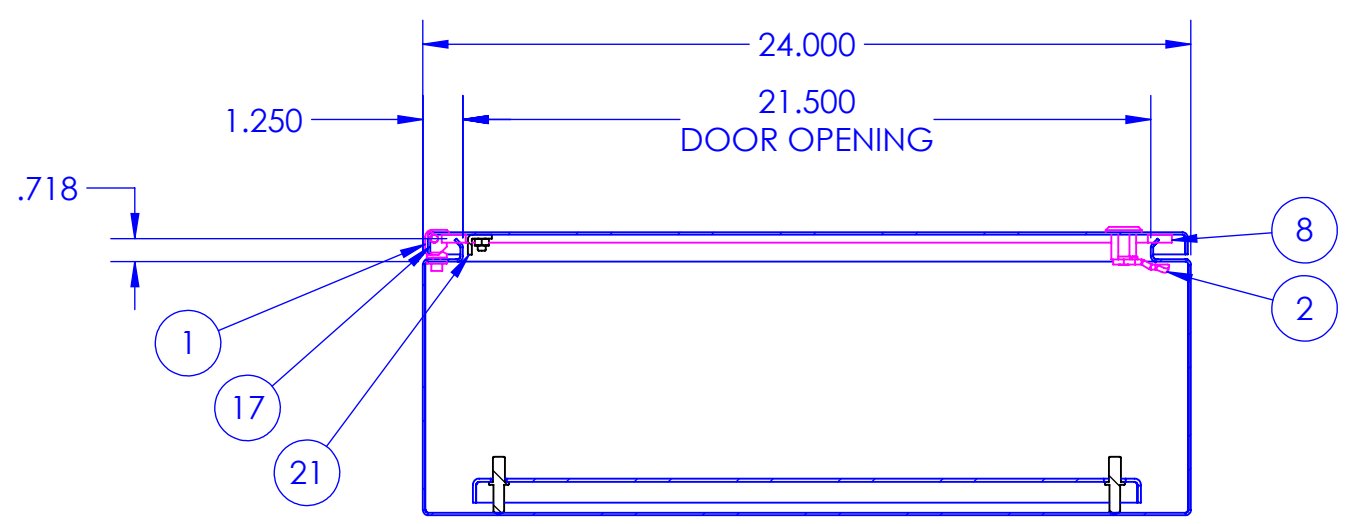
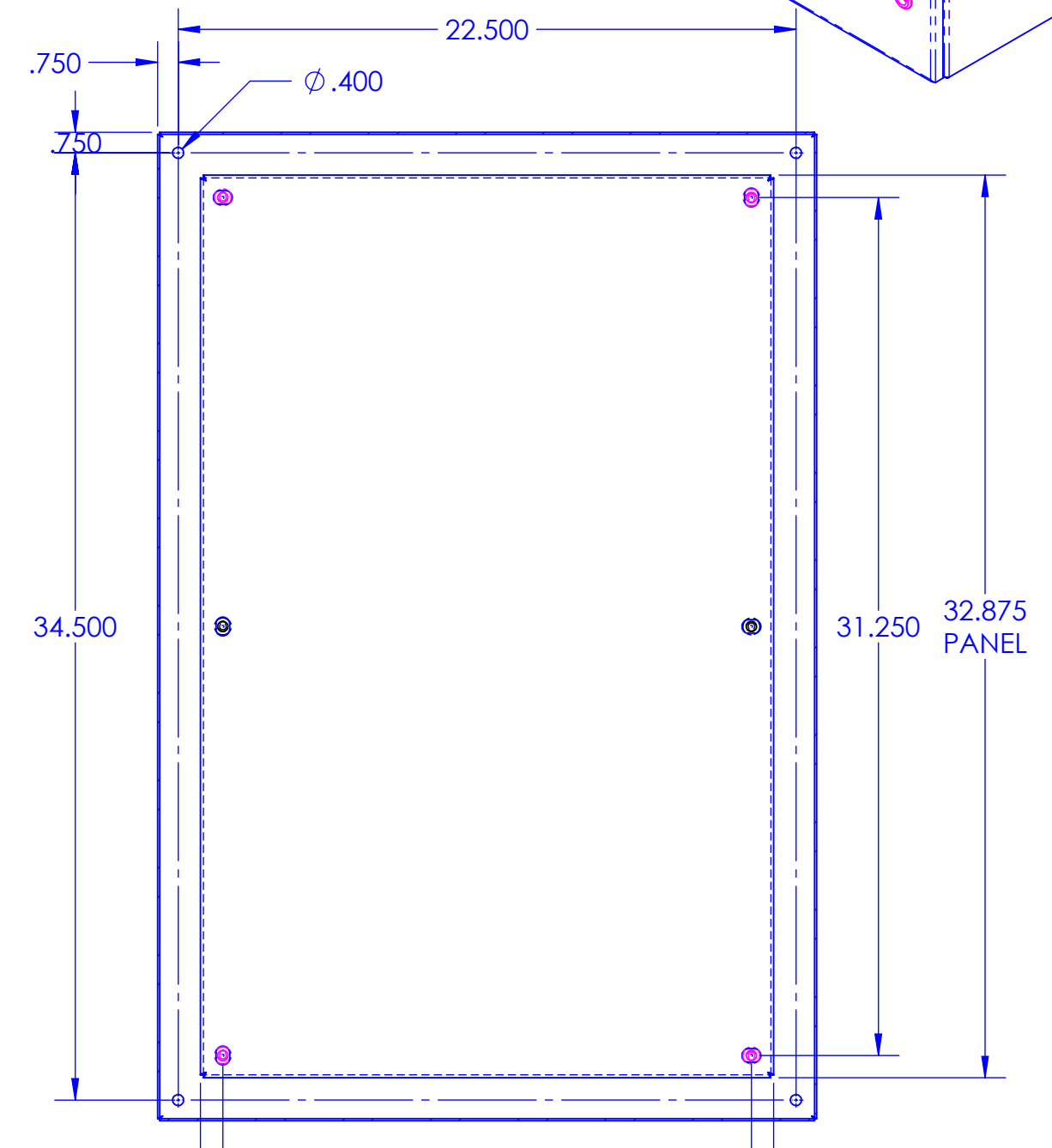
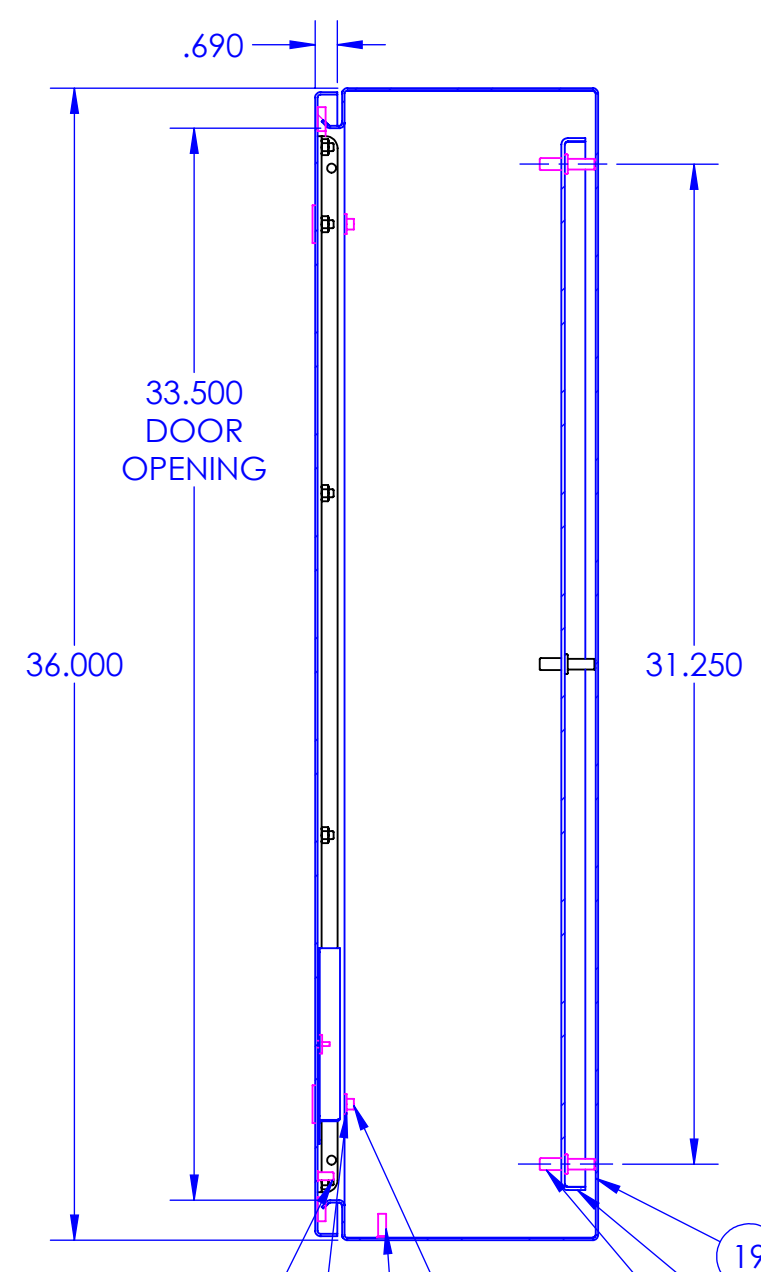
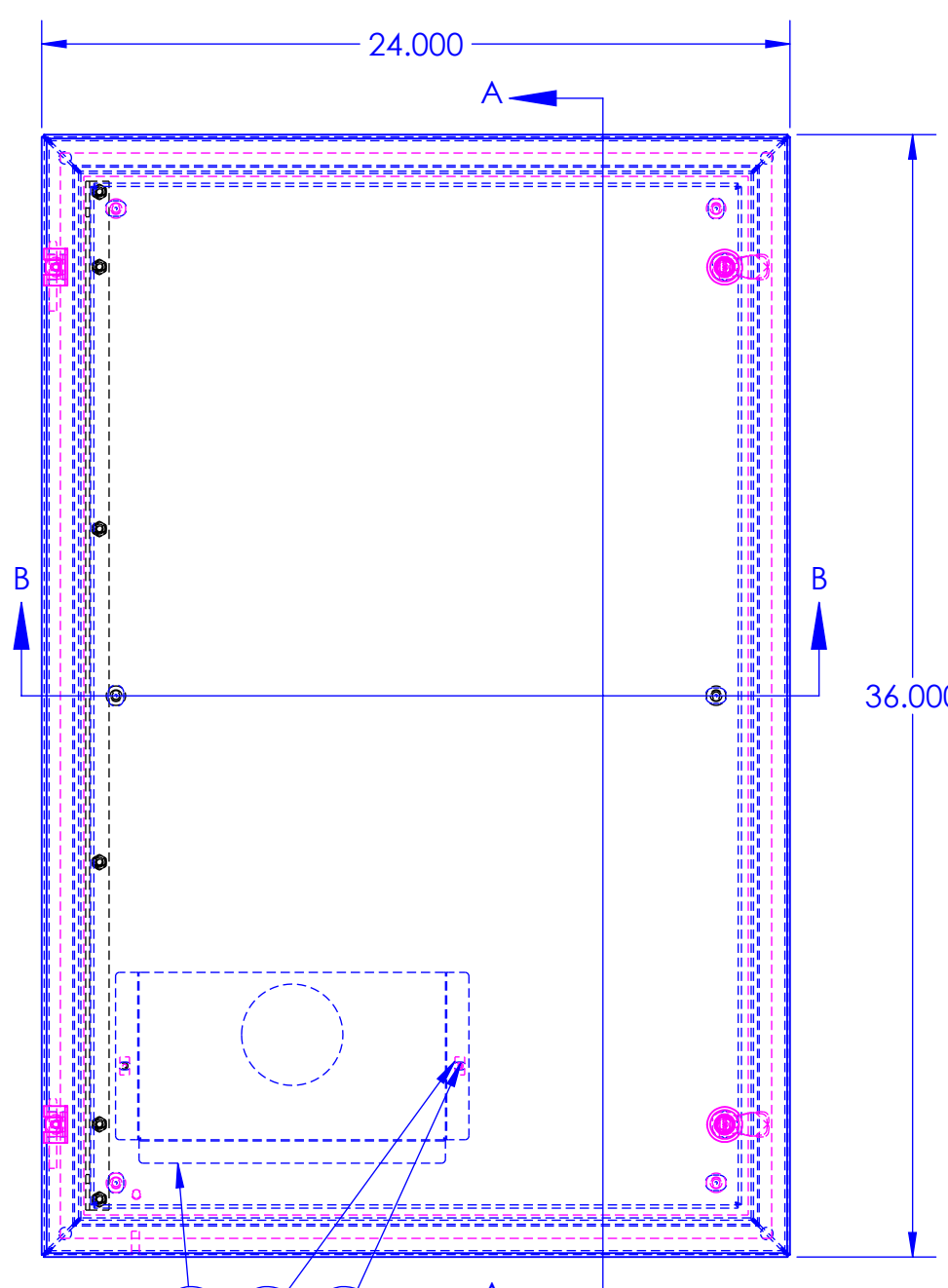
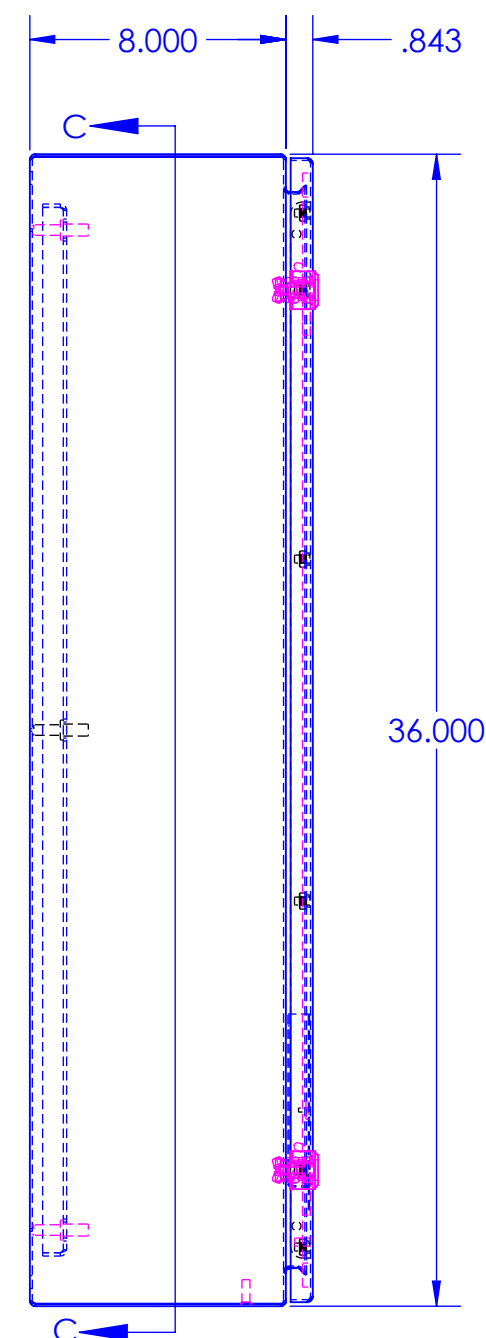
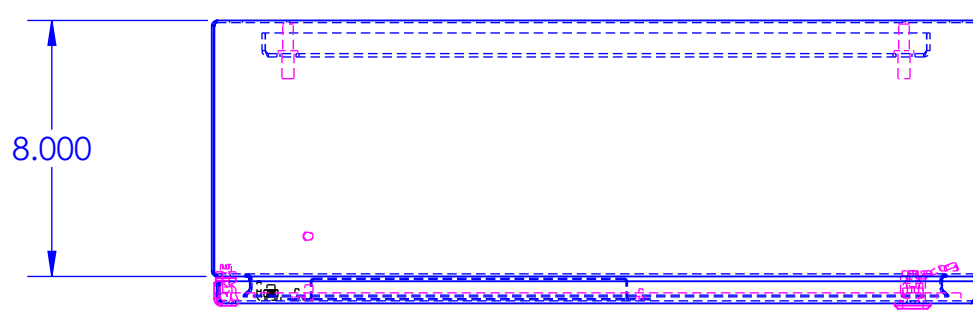
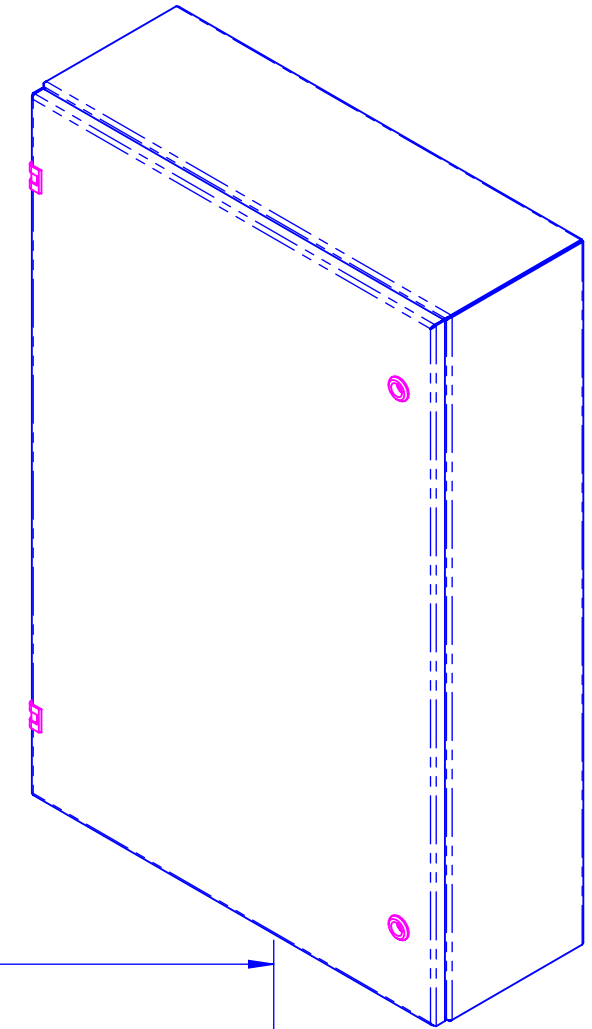

PROPRIETARY AND CONFIDENTIAL
 THE INFORMATION CONTAINED IN THIS DRAWING IS THE SOLE PROPERTY OF RALSTON METAL PRODUCTS. ANY REPRODUCTION IN PART OR AS A WHOLE WITHOUT THE WRITTEN PERMISSION OF RALSTON METAL PRODUCTS IS PROHIBITED.

UNLESS OTHERWISE SPECIFIED
 DIMENSIONS ARE IN INCHES
 TOLERANCES:
 FRACTIONAL ± 1/32"
 ANGULAR ± 0.01°
 ONE PLACE DECIMAL ± 0.1"
 TWO PLACE DECIMAL ± 0.01"
 THREE PLACE DECIMAL ± 0.005"
 MATERIAL:

SEE BOM
 FINISH:
 SEE BOM
 DO NOT SCALE DRAWING

NAME: _____ DATE: _____
 DRAWN BY: _____
 ISSUED BY: _____
 JOB ORDER NO: _____

CUSTOMER: _____
 SHOP DRAWING NUMBER: _____

SIZE: _____ PART NAME: _____ REV: _____
C ASSEMBLY
 PART NO. V-SS-362408
 WEIGHT: 88.359

55 WATSON ROAD
 GUELPH, ONTARIO N1L 1E2
 PHONE: (519) 836-2968
 TOLL FREE: 1-800-265-7611
 FAX: (519) 836-9793
 WWW.RALSTONMETAL.COM

THIRD ANGLE PROJECTION

SHEET 1 OF 1