

REVISIONS			
REV.	DESCRIPTION	DATE	APPROVED

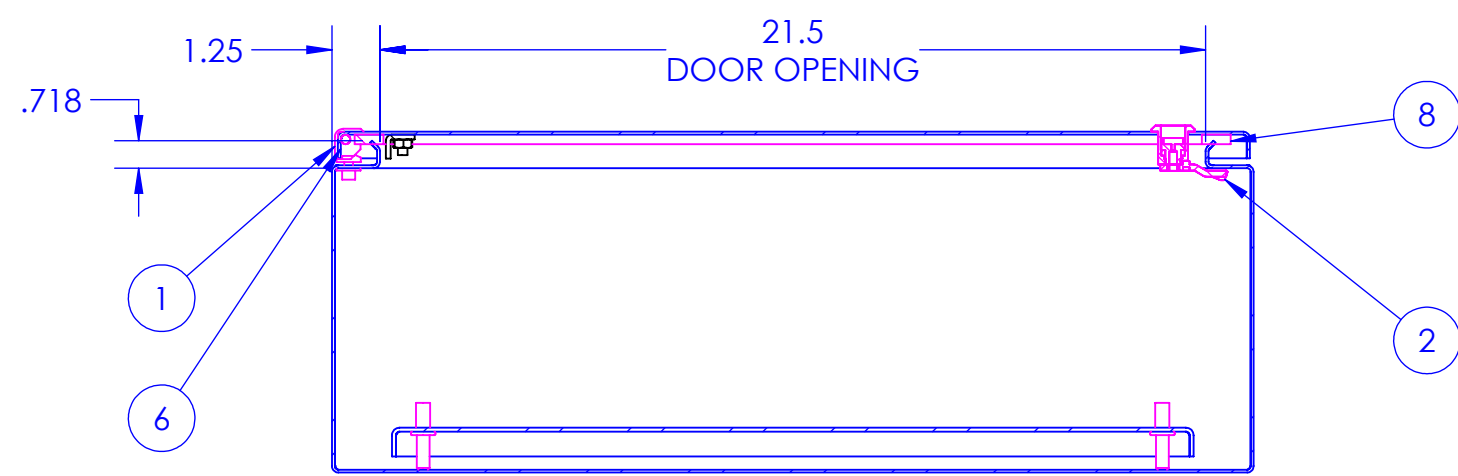
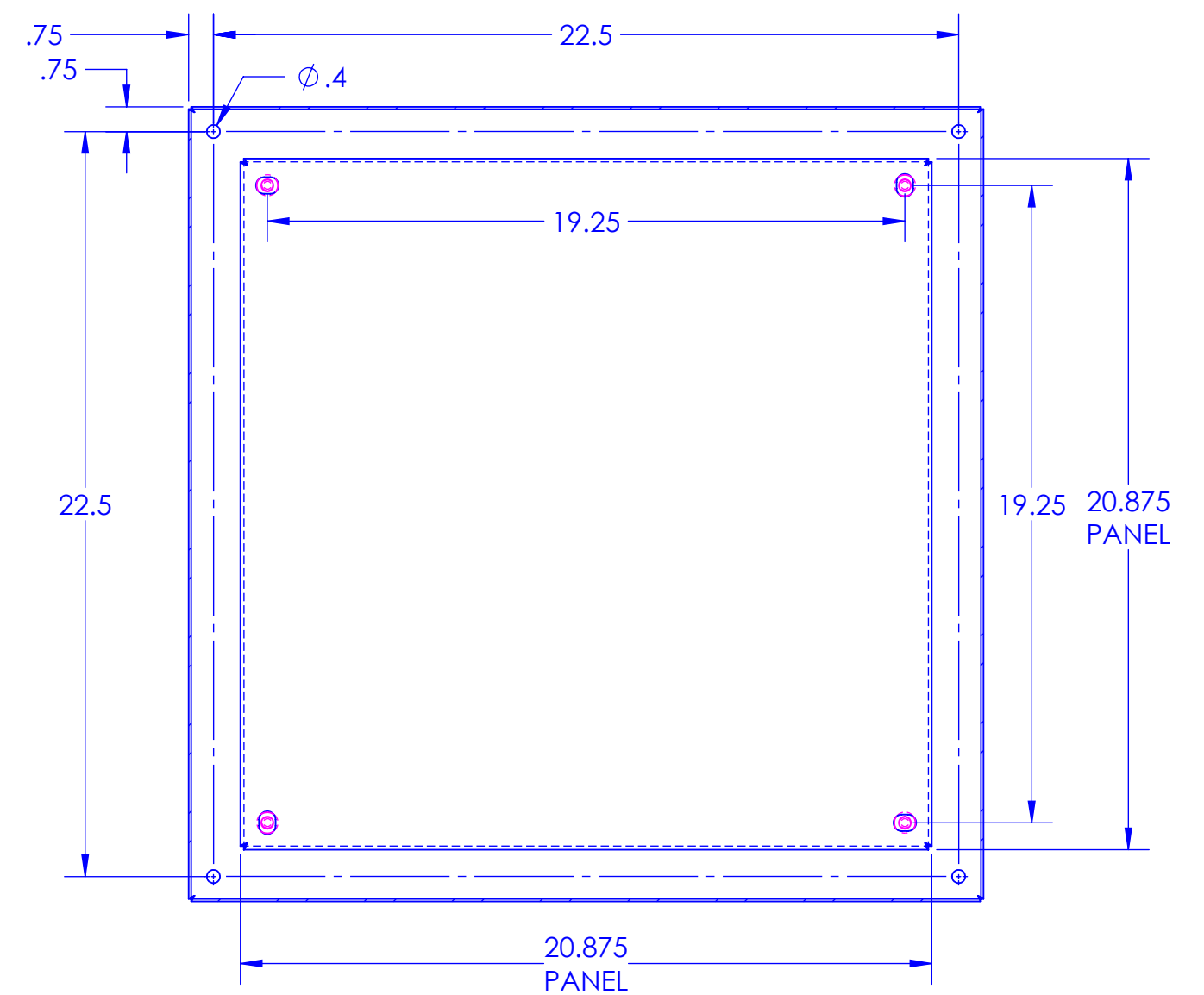
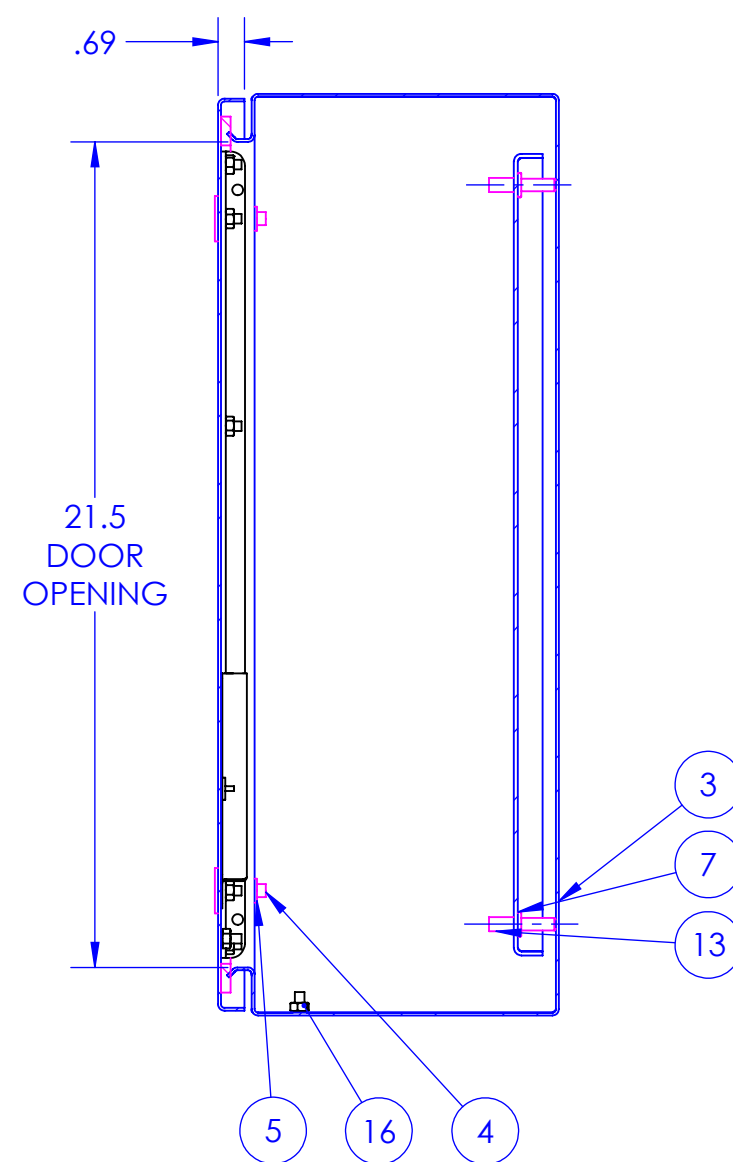
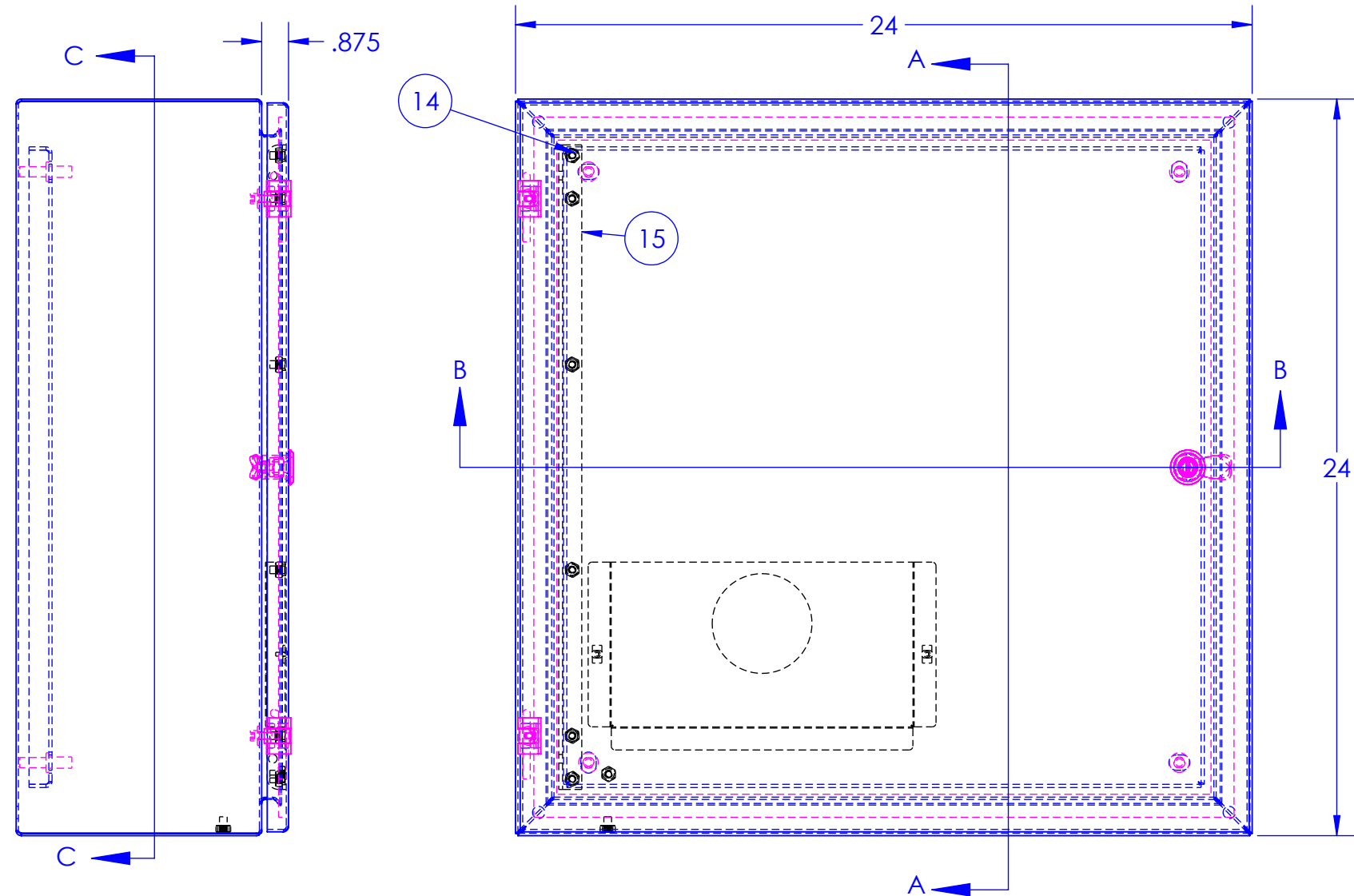
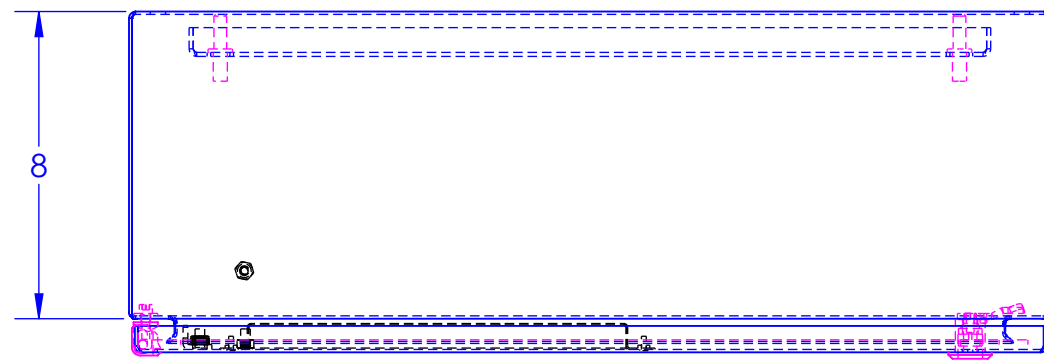
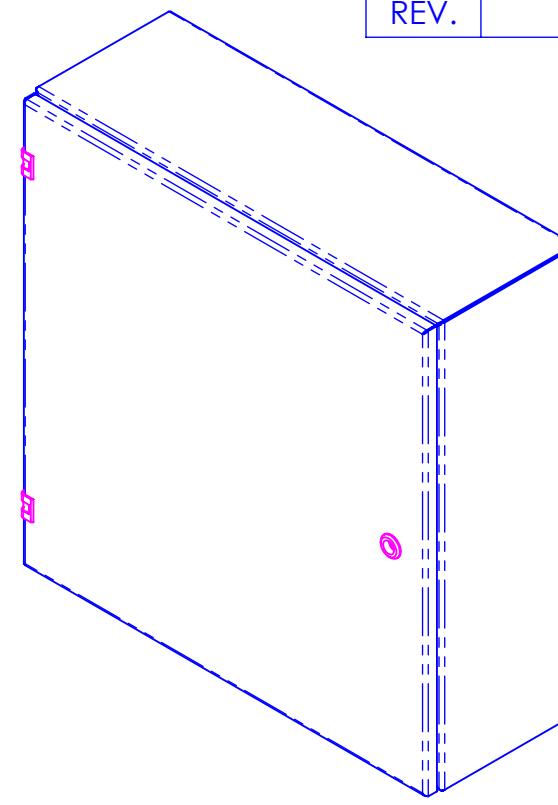

PROPRIETARY AND CONFIDENTIAL THE INFORMATION CONTAINED IN THIS DRAWING IS THE SOLE PROPERTY OF RALSTON METAL PRODUCTS. ANY REPRODUCTION IN PART OR AS A WHOLE WITHOUT THE WRITTEN PERMISSION OF RALSTON METAL PRODUCTS IS PROHIBITED.	NAME	DATE		55 WATSON ROAD QUELUP, ONTARIO N1L 1E2 PHONE: (519) 836-2969 TOLL FREE: 1-800-265-7611 FAX: (519) 836-9793 WWW.RALSTONMETAL.COM
	DRAWN BY	DATE		
UNLESS OTHERWISE SPECIFIED DIMENSIONS ARE IN INCHES TOLERANCES: FRACTIONAL ±1/32" ANGULAR ±MACH 1" ONE PLACE DECIMAL ±0.1" TWO PLACE DECIMAL ±0.01" THREE PLACE DECIMAL ±0.005" MATERIAL:	ISSUED BY	DATE	CUSTOMER DRAWING NO.: SHOP DRAWING NUMBER: V-SS-242408	SIZE PART NAME: REV. C ASSEMBLY
	SEE BOM	DATE		
FINISH:	THIRD ANGLE PROJECTION			
SEE BOM				