

REVISIONS			
REV.	DESCRIPTION	DATE	APPROVED

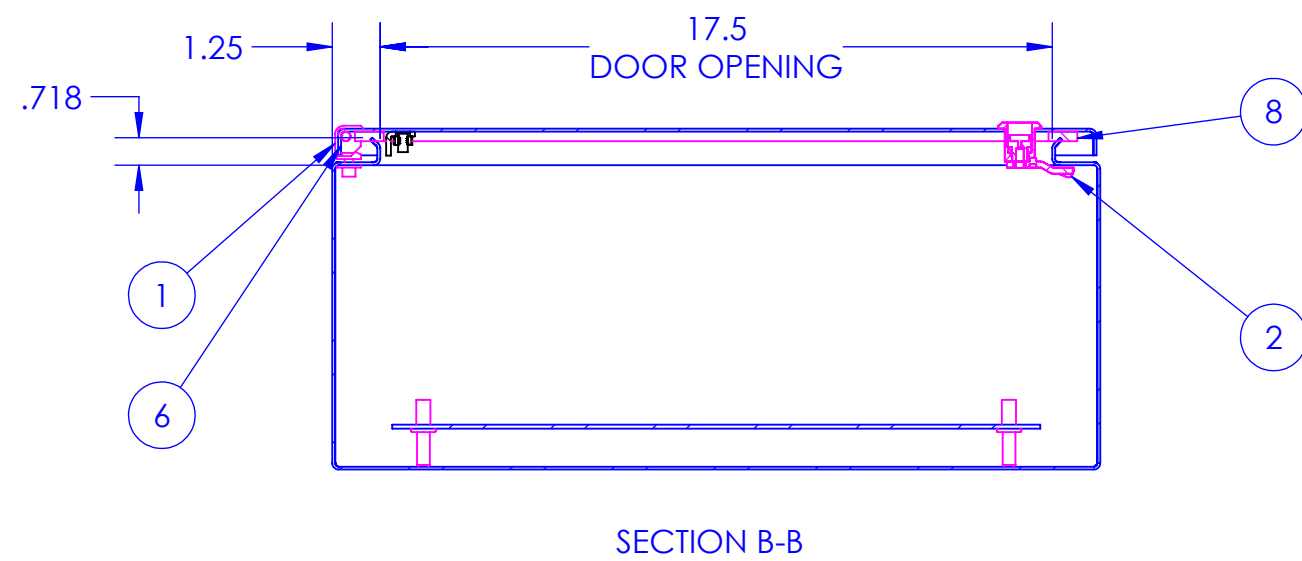
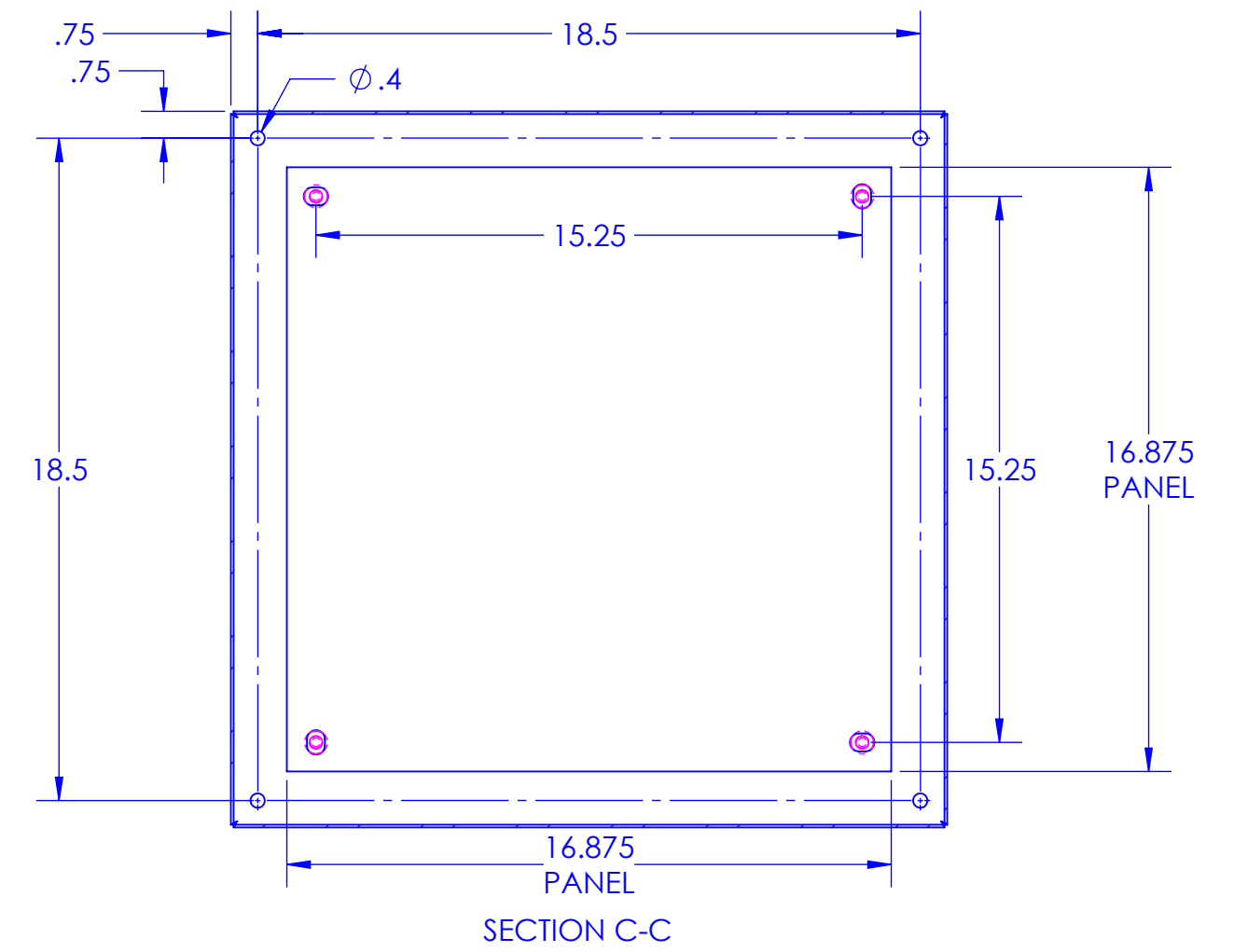
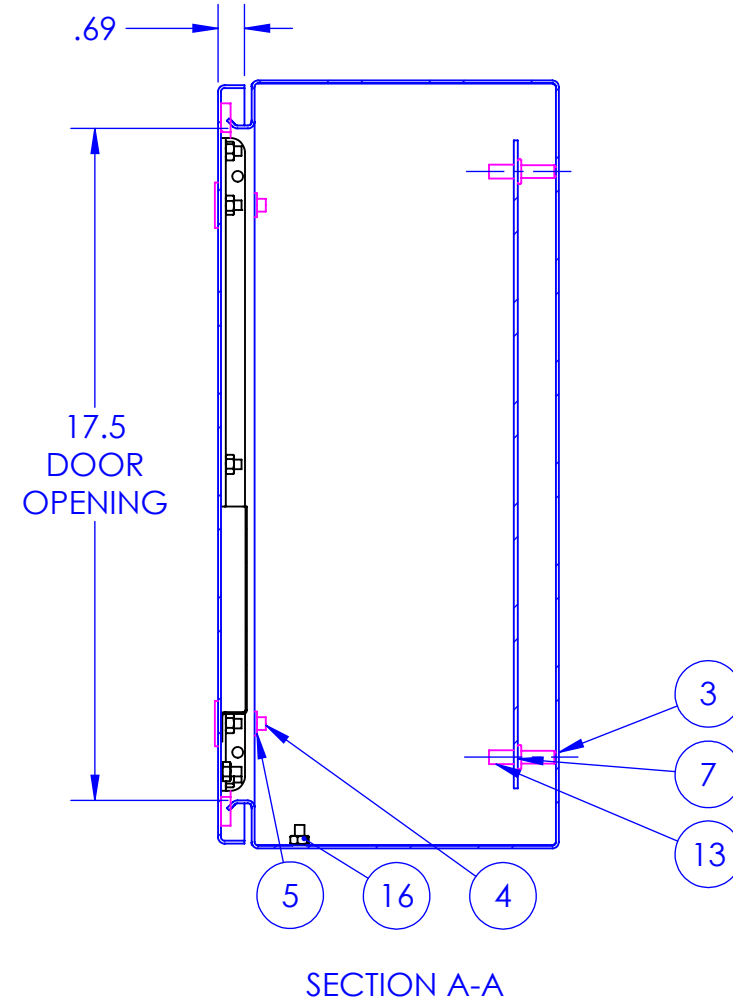
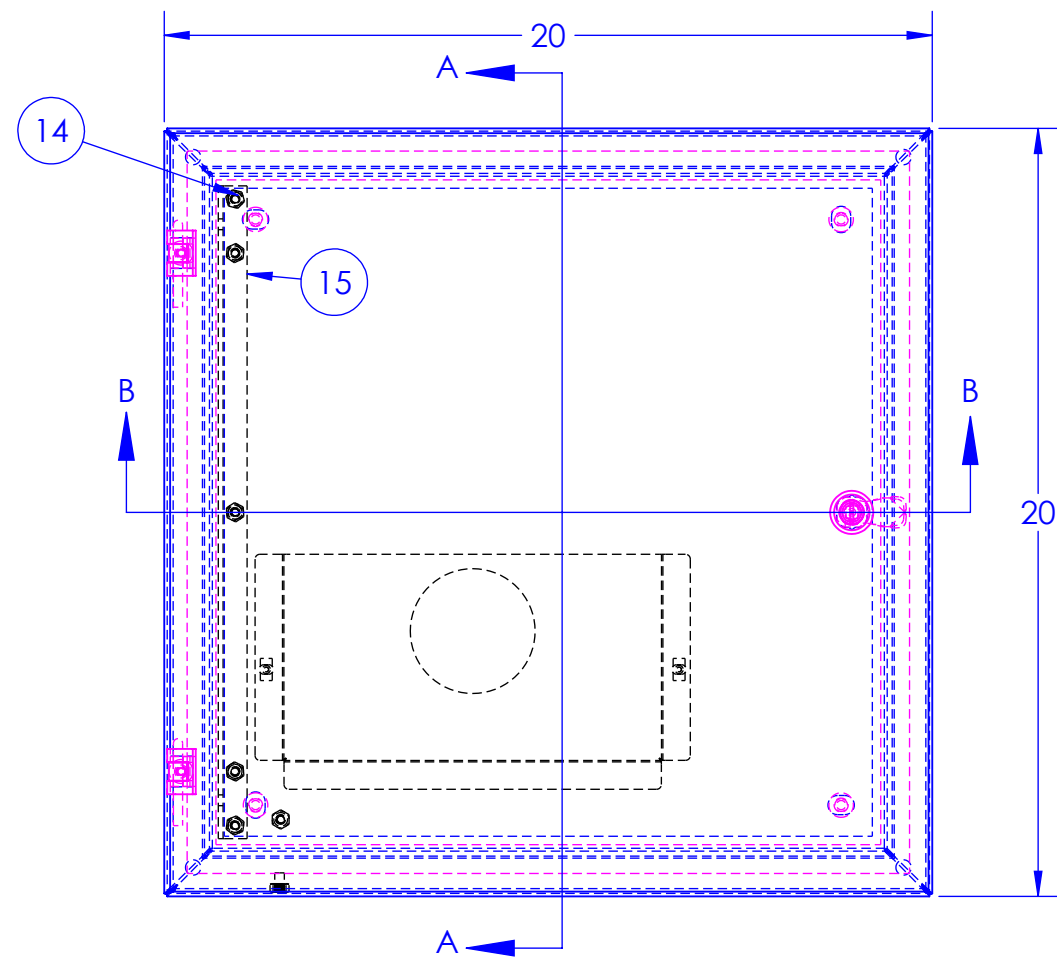
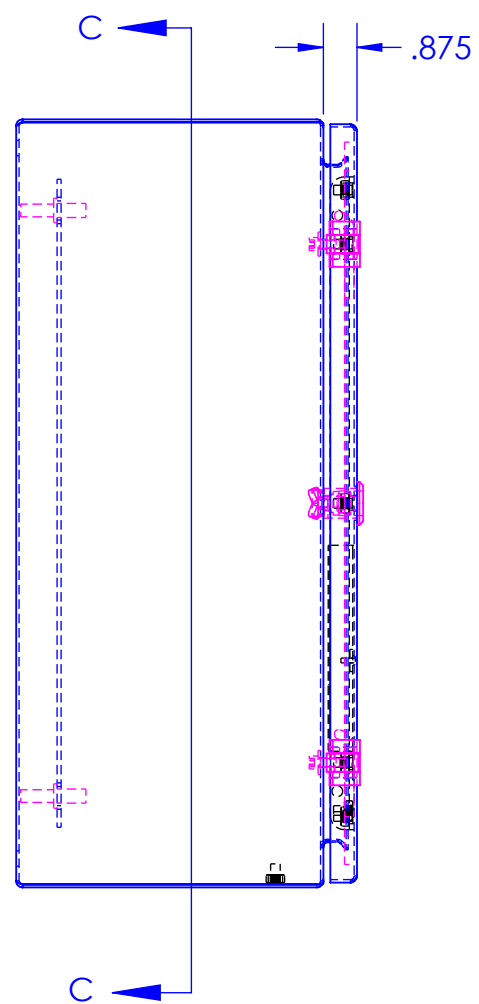
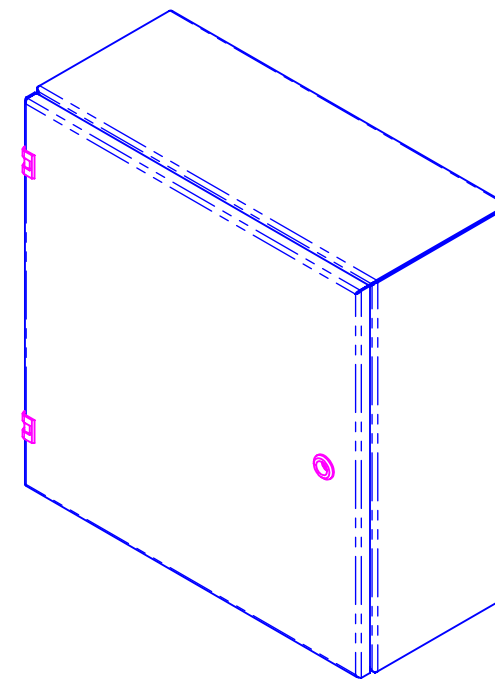
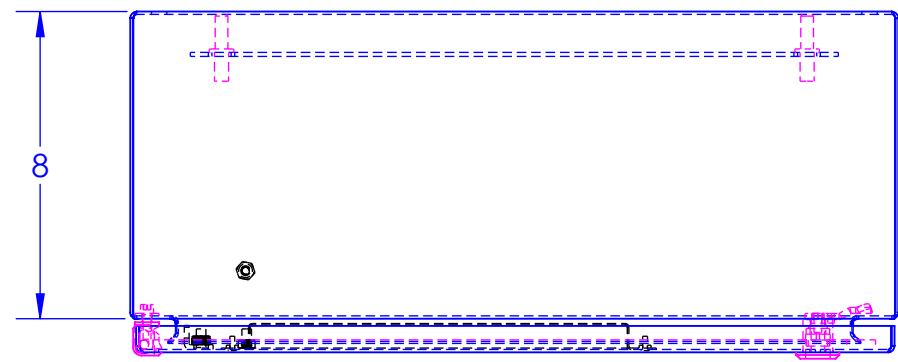

PROPRIETARY AND CONFIDENTIAL THE INFORMATION CONTAINED IN THIS DRAWING IS THE SOLE PROPERTY OF RALSTON METAL PRODUCTS. ANY REPRODUCTION IN PART OR AS A WHOLE WITHOUT THE WRITTEN PERMISSION OF RALSTON METAL PRODUCTS IS PROHIBITED.	NAME	DATE		55 WATSON ROAD QUELUP, ONTARIO N1L 1E2 PHONE: (519) 836-2969 TOLL FREE: 1-800-265-7611 FAX: (519) 836-9793 WWW.RALSTONMETAL.COM
	DRAWN BY	WAYNE SYNNOIT		
UNLESS OTHERWISE SPECIFIED DIMENSIONS ARE IN INCHES TOLERANCES: FRACTIONAL ±1/32" ANGULAR ±MACH1" ONE PLACE DECIMAL ±0.1" TWO PLACE DECIMAL ±0.01" THREE PLACE DECIMAL ±0.005" MATERIAL:	ISSUED BY	WAYNE SYNNOIT	1/17/2023	CUSTOMER: SHOP DRAWING NUMBER: V-SS-202008
	JOB ORDER NO.			
SEE BOM	CUSTOMER DRAWING NO.			
FINISH:				
SEE BOM				
DO NOT SCALE DRAWING	THIRD ANGLE PROJECTION			
		(AUTHORIZED SIGNATURE IN RED) 		SIZE PART NAME: C ASSEMBLY
		PART NO. V-SS-202008 WEIGHT: 44.923		REV. SHEET 1 OF 1