

REVISIONS			
REV.	DESCRIPTION	DATE	APPROVED

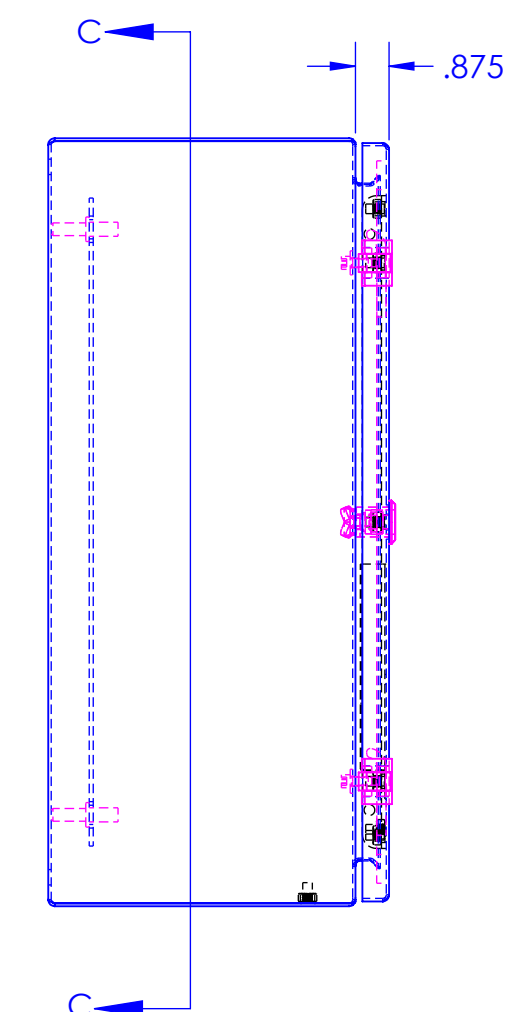
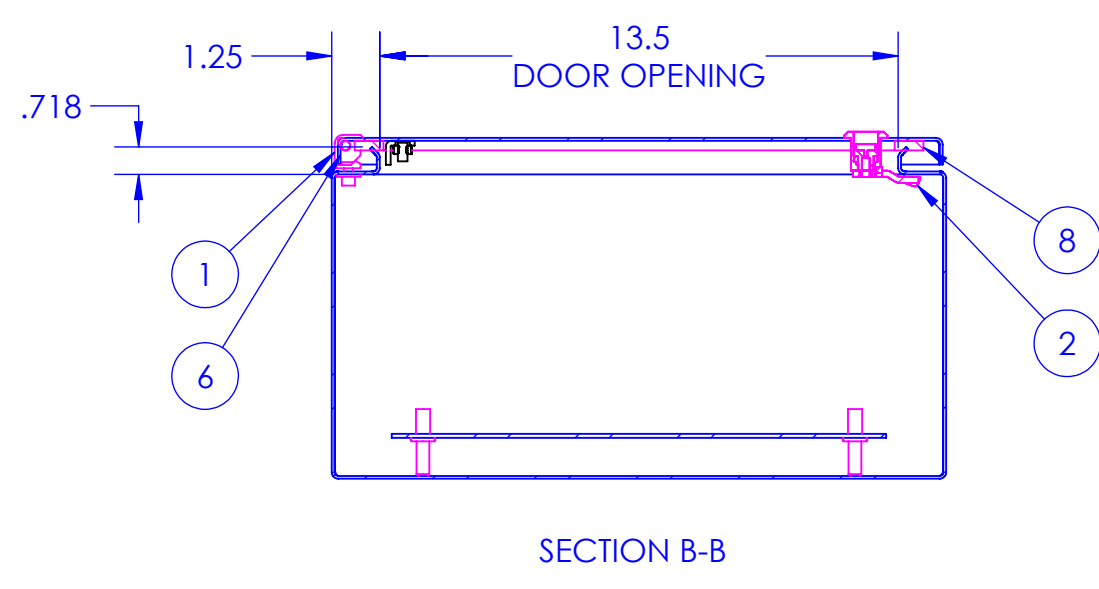
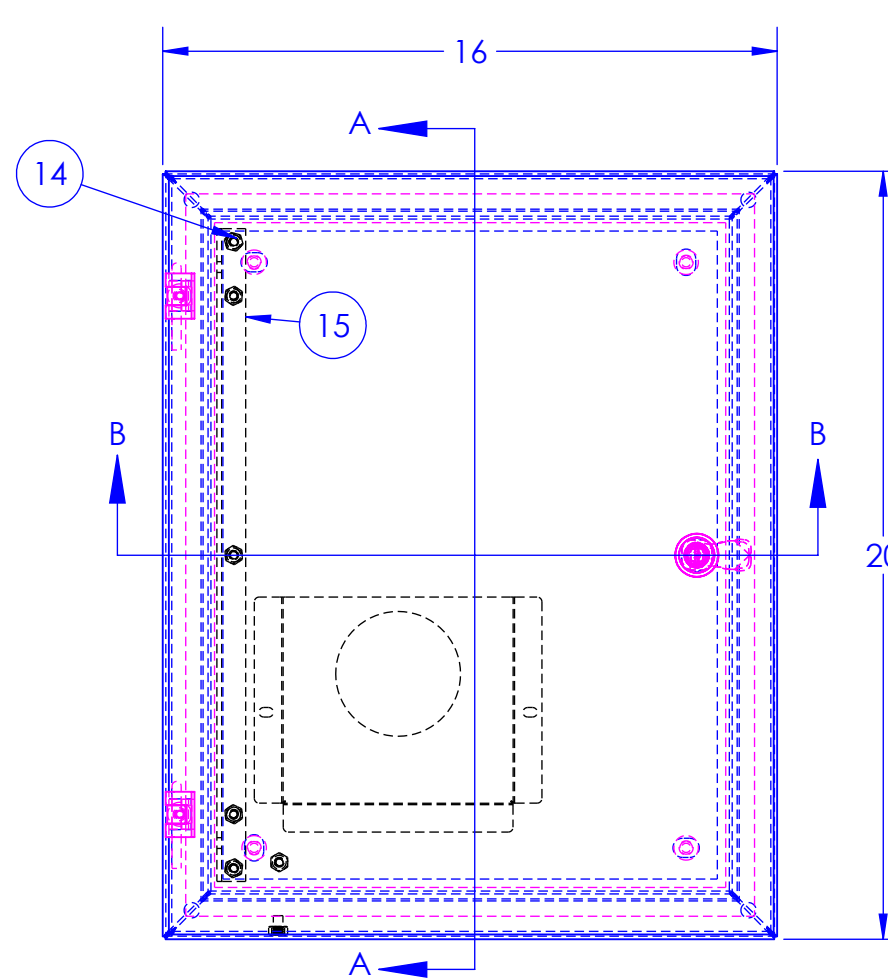
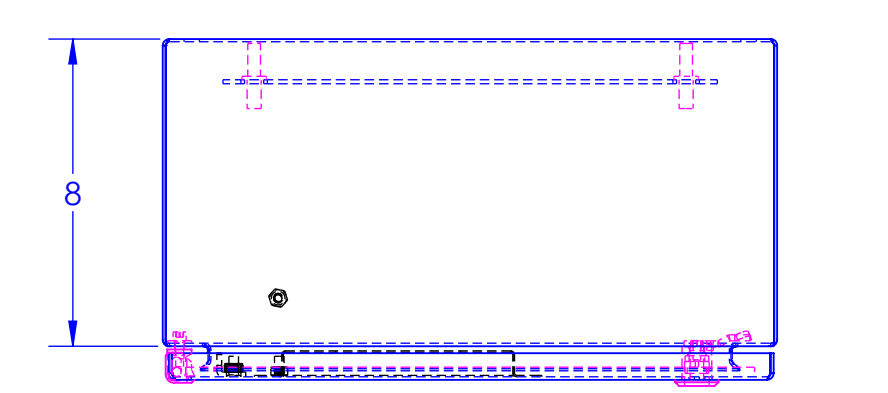
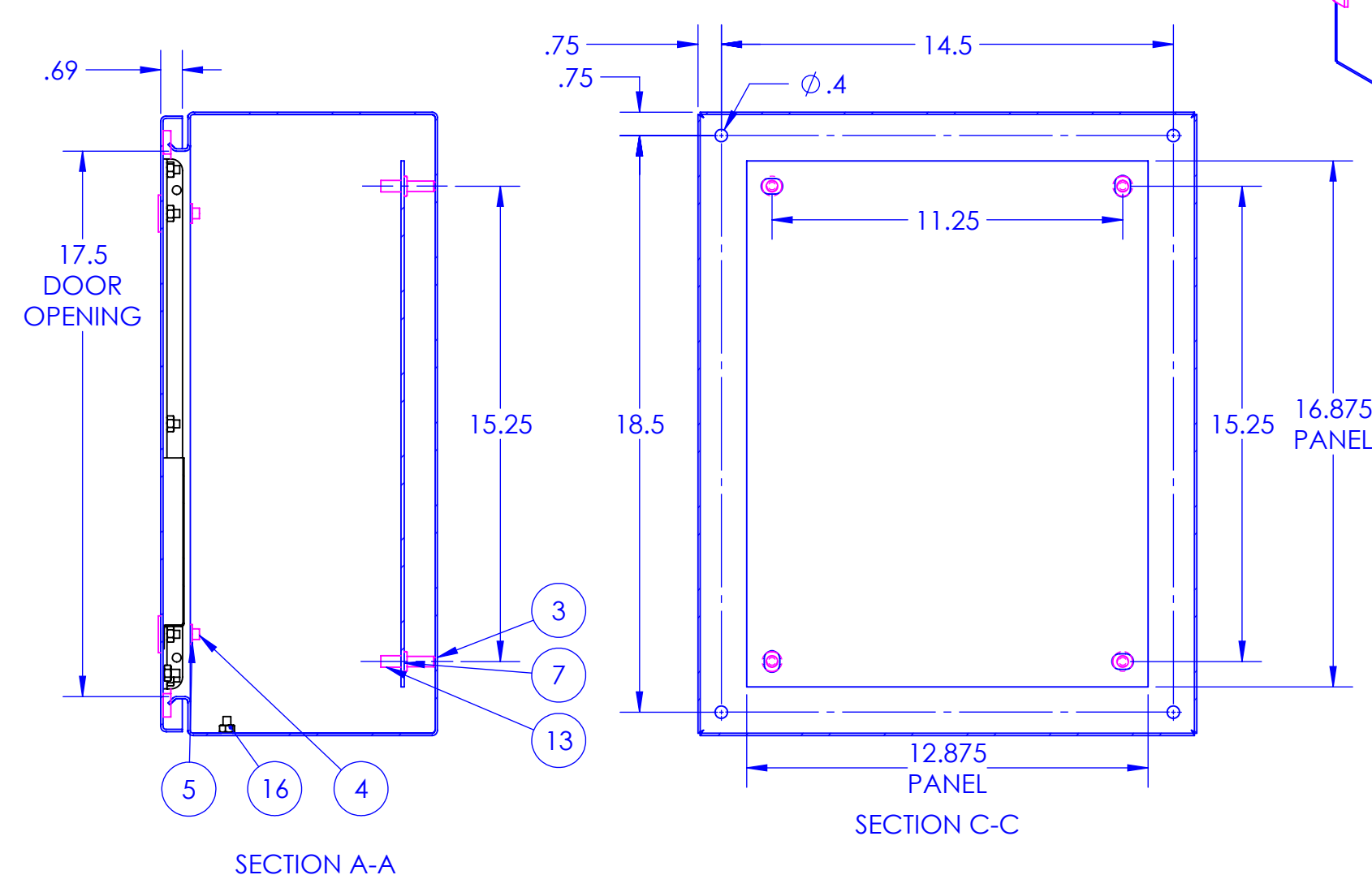
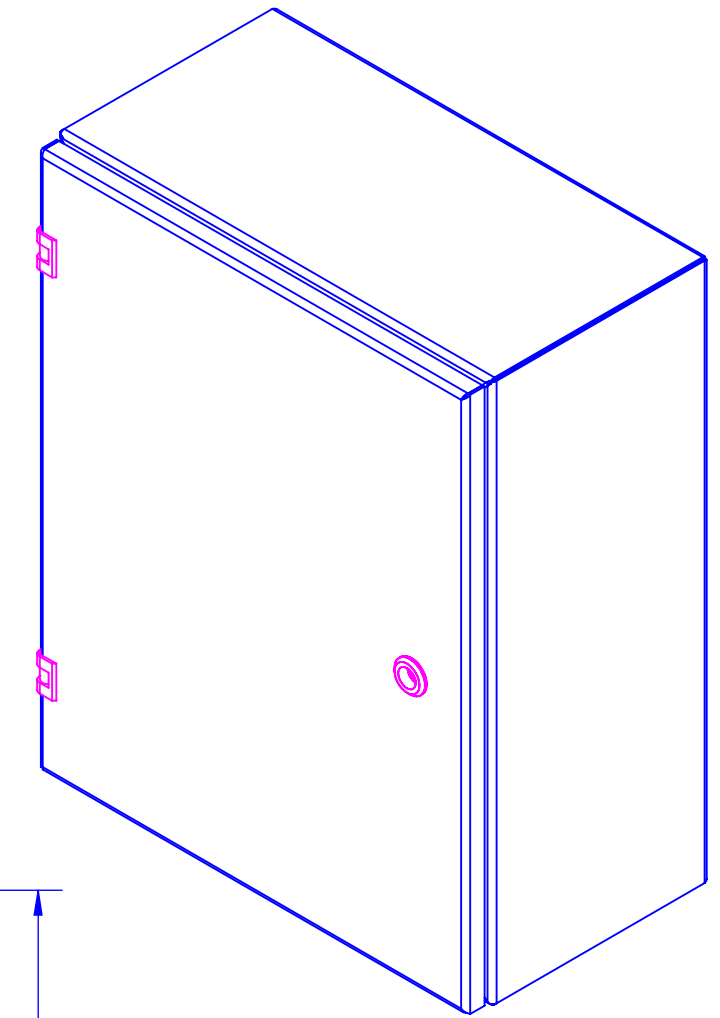

PROPRIETARY AND CONFIDENTIAL THE INFORMATION CONTAINED IN THIS DRAWING IS THE SOLE PROPERTY OF RALSTON METAL PRODUCTS. ANY REPRODUCTION IN PART OR AS A WHOLE WITHOUT THE WRITTEN PERMISSION OF RALSTON METAL PRODUCTS IS PROHIBITED.	NAME	DATE		55 WATSON ROAD QUELPP, ONTARIO N1L 1E2 PHONE: (519) 836-2969 TOLL FREE: 1-800-265-7611 FAX: (519) 836-9793
	DRAWN BY	WAYNE SYMNOIT		
UNLESS OTHERWISE SPECIFIED DIMENSIONS ARE IN INCHES TOLERANCES: FRACTIONAL ± 1/32" ANGULAR ± MACH 1" ONE PLACE DECIMAL ± 0.1" TWO PLACE DECIMAL ± 0.01" THREE PLACE DECIMAL ± 0.005" MATERIAL:	ISSUED BY	WAYNE SYMNOIT	1/17/2023	CUSTOMER: SHOP DRAWING NUMBER: V-SS-201608
	JOB ORDER NO.	CUSTOMER DRAWING NO.		
SEE BOM	(AUTHORIZED SIGNATURE IN RED) 			SIZE PART NAME: C ASSEMBLY
SEE BOM	THIRD ANGLE PROJECTION 			PART NO. V-SS-201608 SCALE: 1:5 WEIGHT: 37.422 SHEET 1 OF 1