

4

3

2

1

REVISIONS			
REV.	DESCRIPTION	DATE	APPROVED

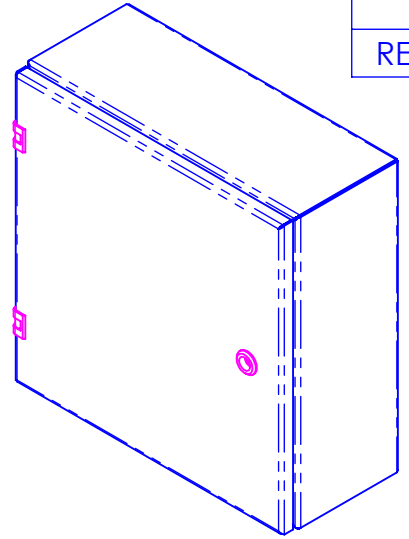
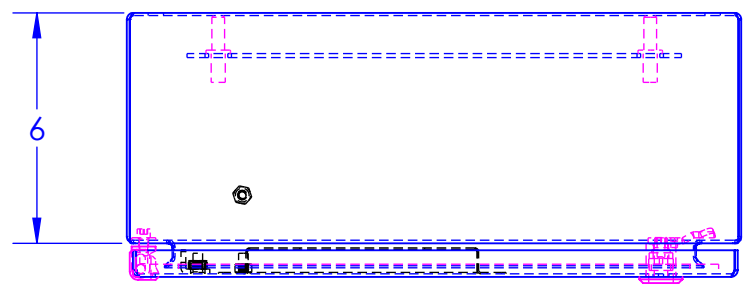

B

B

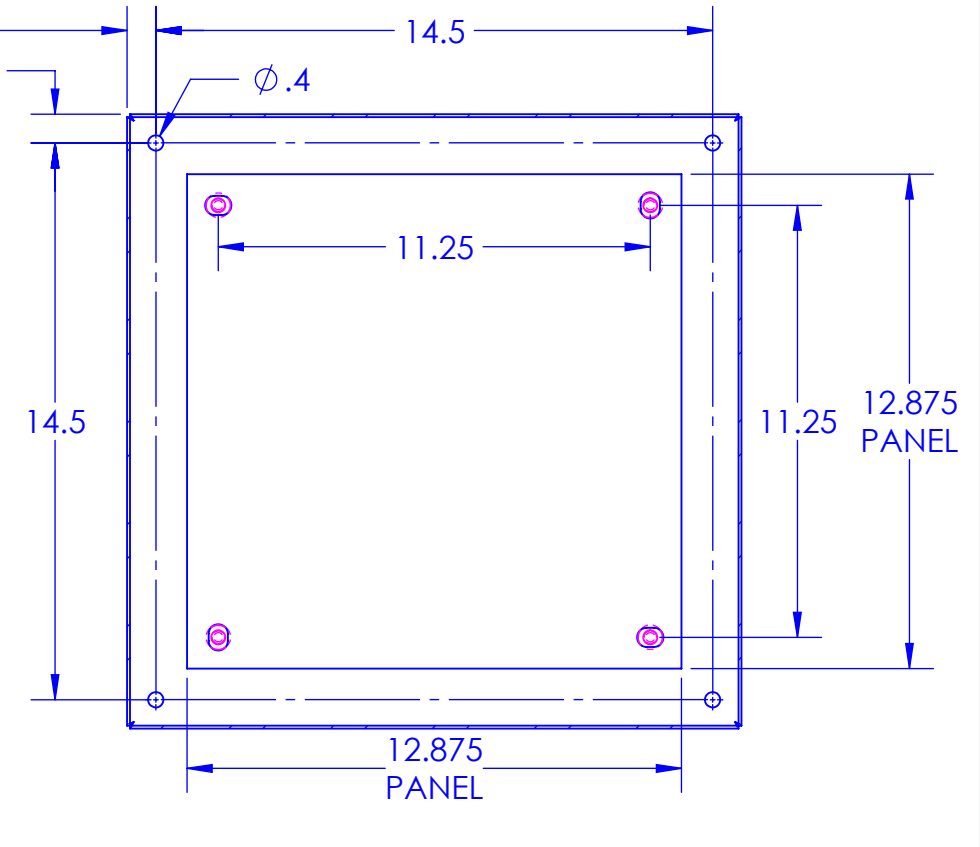
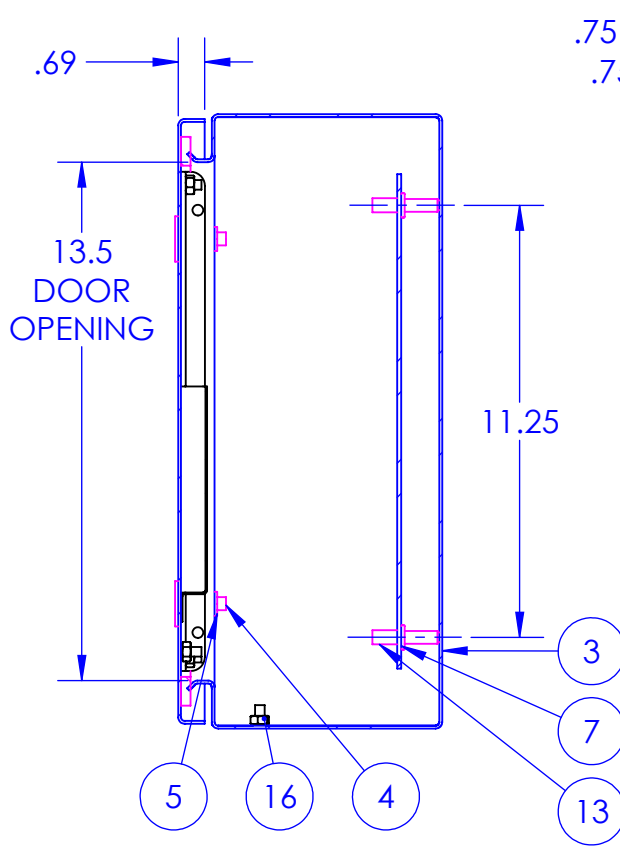
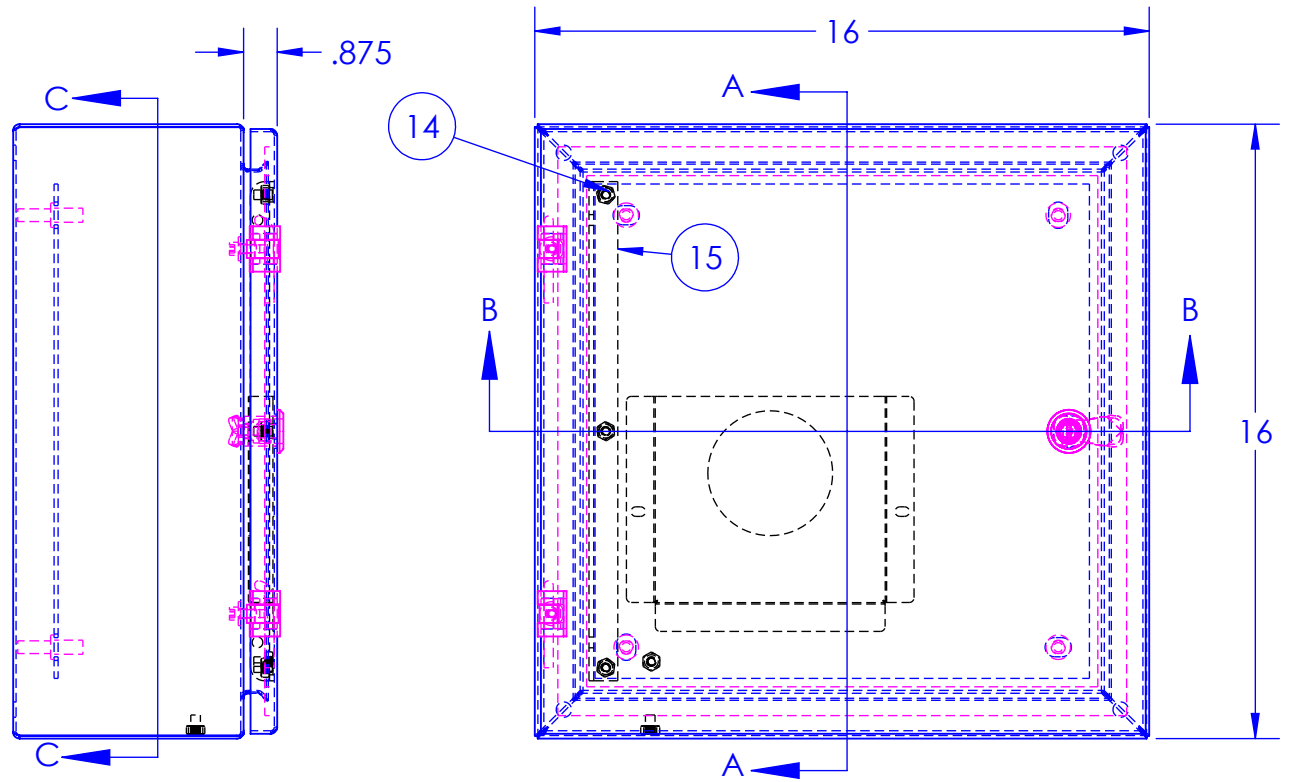

A

A

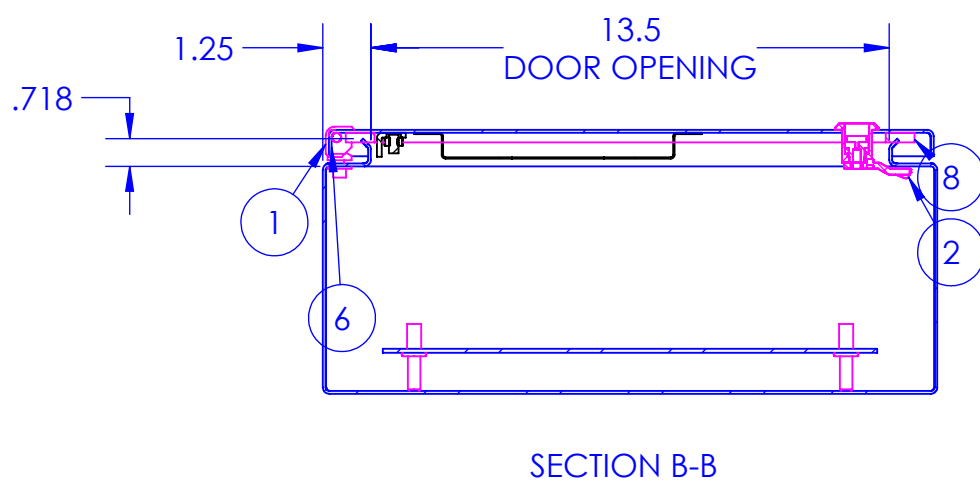

PROPRIETARY AND CONFIDENTIAL THE INFORMATION CONTAINED IN THIS DRAWING IS THE SOLE PROPERTY OF RALSTON METAL PRODUCTS. ANY REPRODUCTION IN PART OR AS A WHOLE WITHOUT THE WRITTEN PERMISSION OF RALSTON METAL PRODUCTS IS PROHIBITED. UNLESS OTHERWISE SPECIFIED DIMENSIONS ARE IN INCHES TOLERANCES: FRACTIONAL: $\pm 1/32"$ ANGULAR: MACH $\pm 1^\circ$ BEND $\pm 1/32"$ ONE PLACE DECIMAL $\pm 0.1"$ TWO PLACE DECIMAL $\pm 0.01"$ THREE PLACE DECIMAL $\pm 0.005"$ MATERIAL: SEE BOM FINISH: SEE BOM DO NOT SCALE DRAWING	NAME DRAWN BY WAYNE SYNNOTT ISSUED BY WAYNE SYNNOTT JOB ORDER NO: CUSTOMER DRAWING NO: (AUTHORIZED SIGNATURE IN RED) 	DATE 1/17/2023 1/17/2023 SHOP DRAWING NUMBER: V-SS-161606 SIZE B PART NAME ASSEMBLY PART NO. V-SS-161606 SCALE: 1:5 WEIGHT: 28.428 SHEET 1 OF 1	50 Watson Road Guelph, Ontario N1L 1E2 Phone: (519) 836-2968 Toll Free: 1-800-265-7611 Fax: (519) 836-9763 www.ralstonmetal.com
---	---	---	--

4

3

2

1