

4

3

2

1

REVISIONS			
REV.	DESCRIPTION	DATE	APPROVED

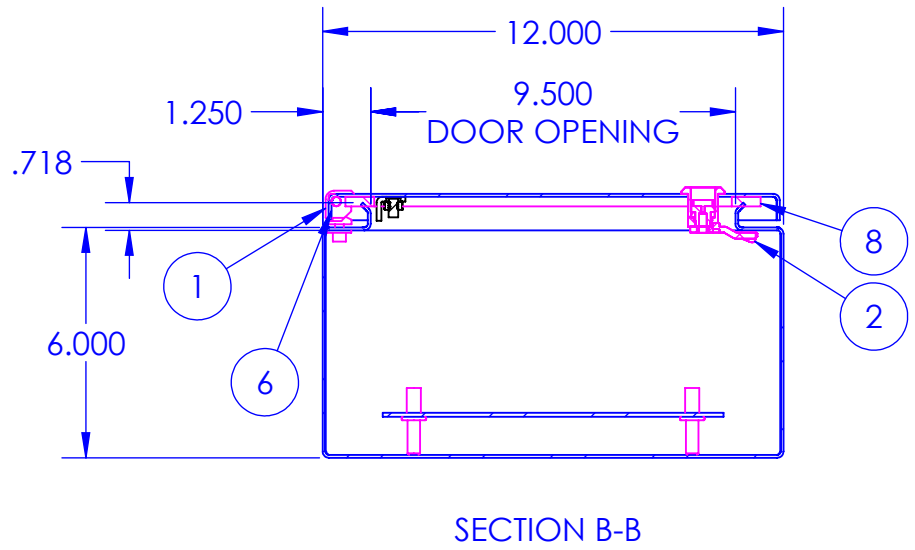
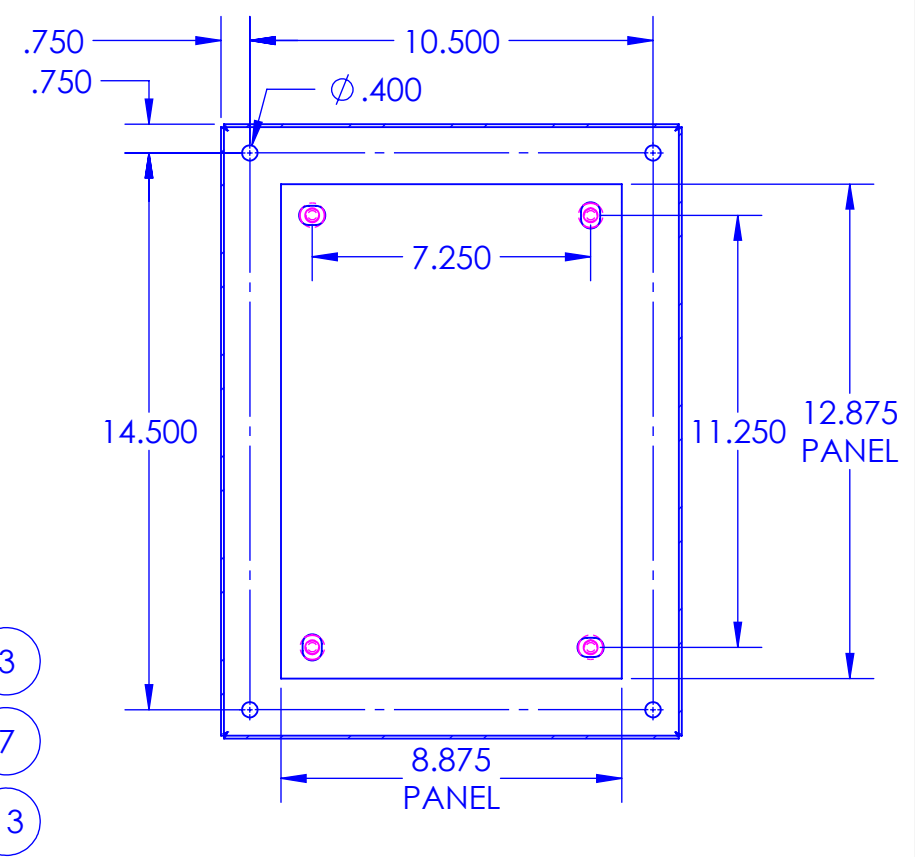
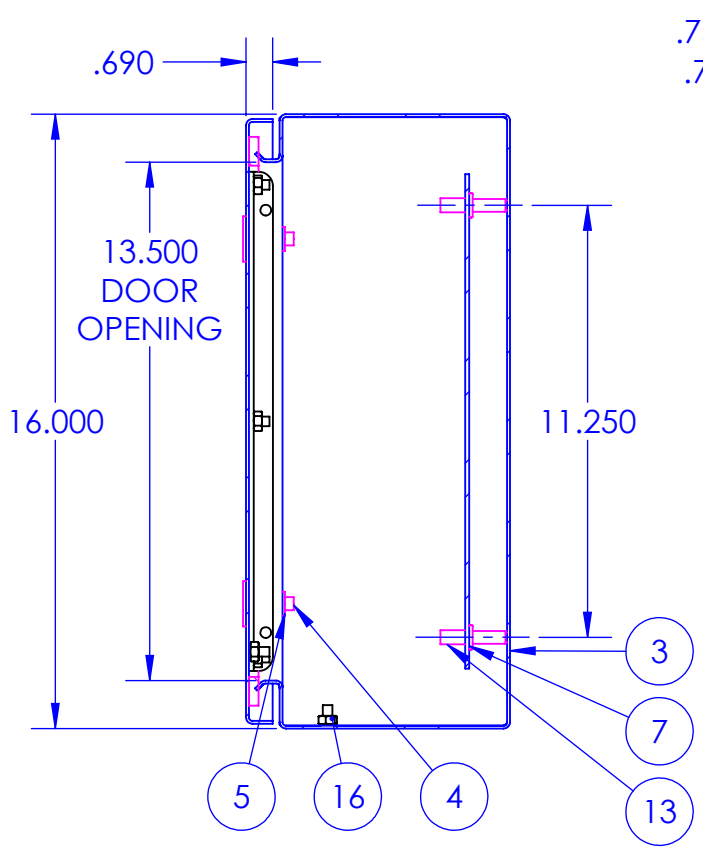
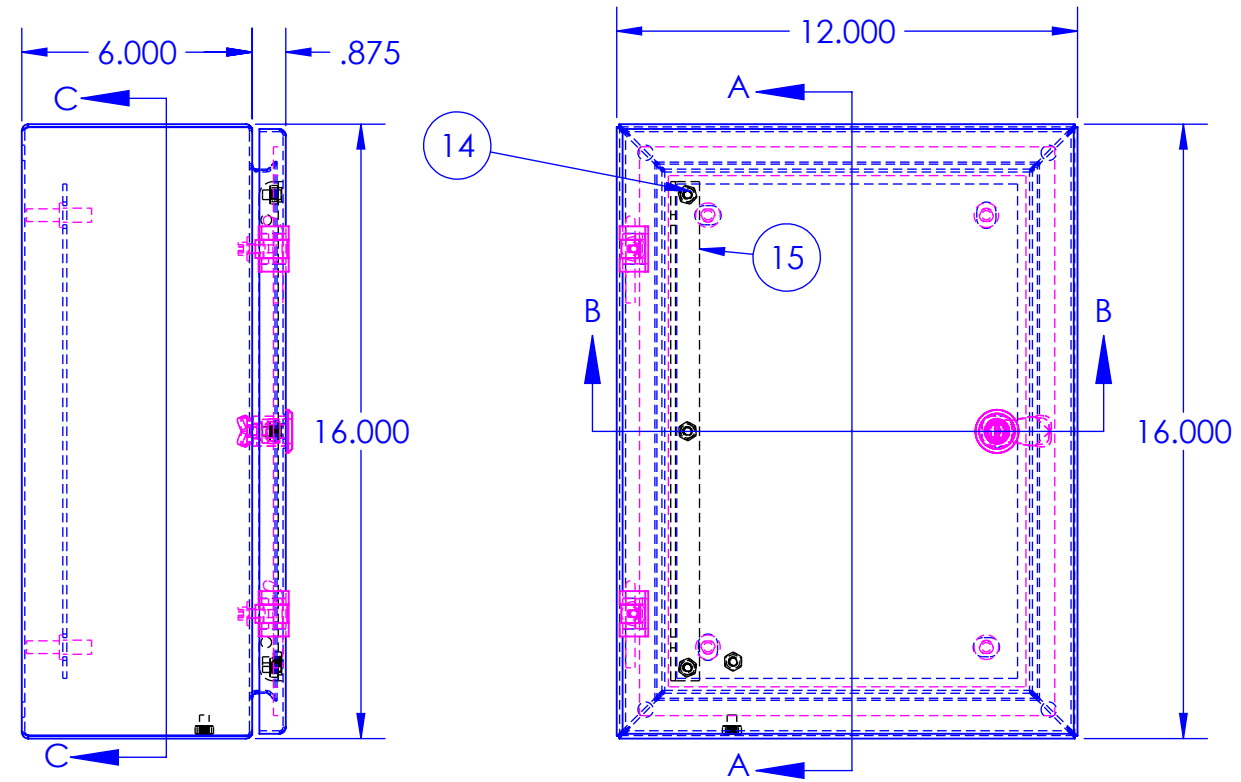
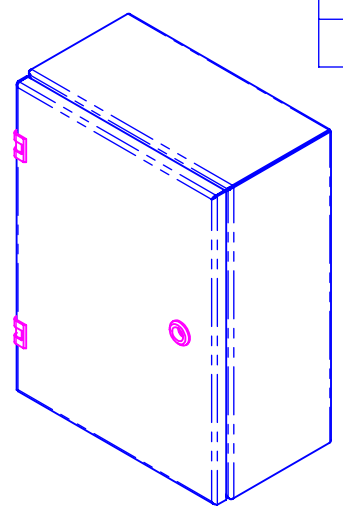
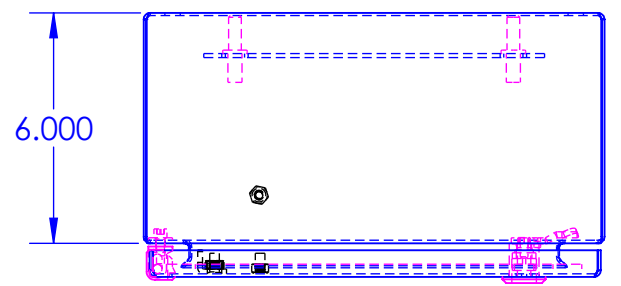

PROPRIETARY AND CONFIDENTIAL
 THE INFORMATION CONTAINED IN THIS DRAWING IS THE SOLE PROPERTY OF RALSTON METAL PRODUCTS. ANY REPRODUCTION IN PART OR AS A WHOLE WITHOUT THE WRITTEN PERMISSION OF RALSTON METAL PRODUCTS IS PROHIBITED.

UNLESS OTHERWISE SPECIFIED
 DIMENSIONS ARE IN INCHES
 TOLERANCES:
 FRACTIONAL: ±1/32"
 ANGULAR: MACH ±1° BEND ±1/32"
 ONE PLACE DECIMAL ±0.1"
 TWO PLACE DECIMAL ±0.01"
 THREE PLACE DECIMAL ±0.005"

MATERIAL:
 SEE BOM

FINISH:
 SEE BOM

DO NOT SCALE DRAWING

NAME	DATE
DRAWN BY DHANIK DESAI	
ISSUED BY DHANIK DESAI	11/16/2022
JOB ORDER NO:	
CUSTOMER DRAWING NO:	
(AUTHORIZED SIGNATURE IN RED)	

50 Watson Road
 Guelph, Ontario N1L 1E2
 Phone: (519) 836-2968
 Toll Free: 1-800-265-7611
 Fax: (519) 836-9763
www.ralstonmetal.com

Ralston
 Metal Products Limited

CUSTOMER:
 SHOP DRAWING NUMBER:
V-SS-161206

SIZE	PART NAME	REV.
B	ASSEMBLY	

PART NO. V-SS-161206
 SCALE: 1:5
 WEIGHT: 22.236
 SHEET 1 OF 1

4

3

2

1

B

B

A

A