

REVISIONS			
REV.	DESCRIPTION	DATE	APPROVED

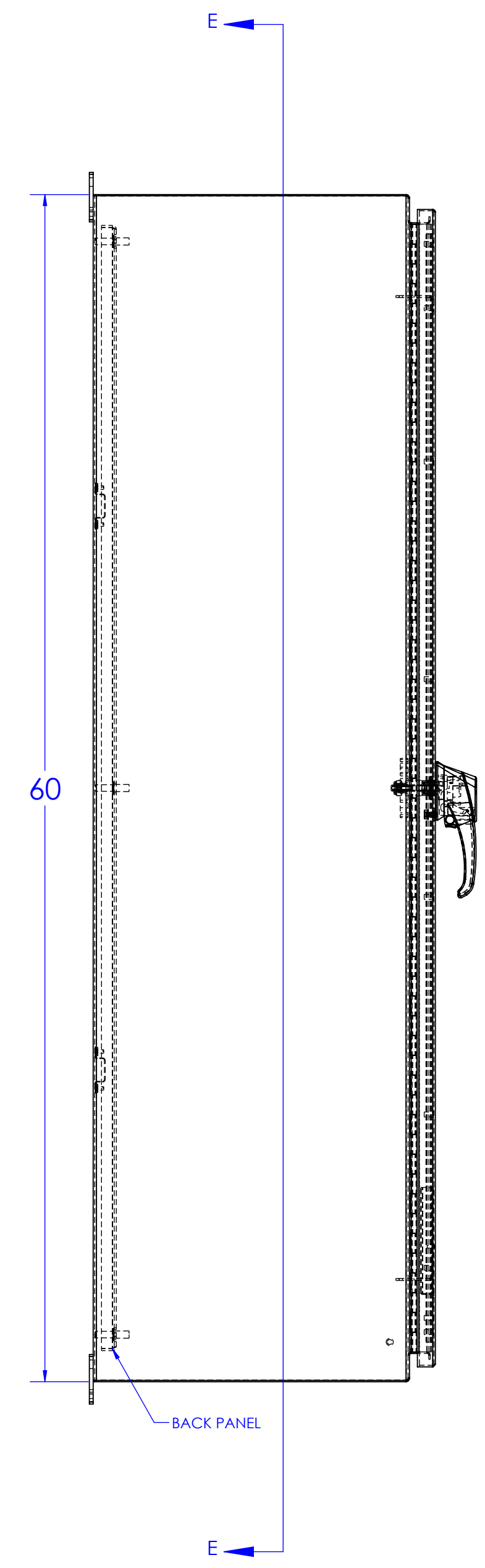
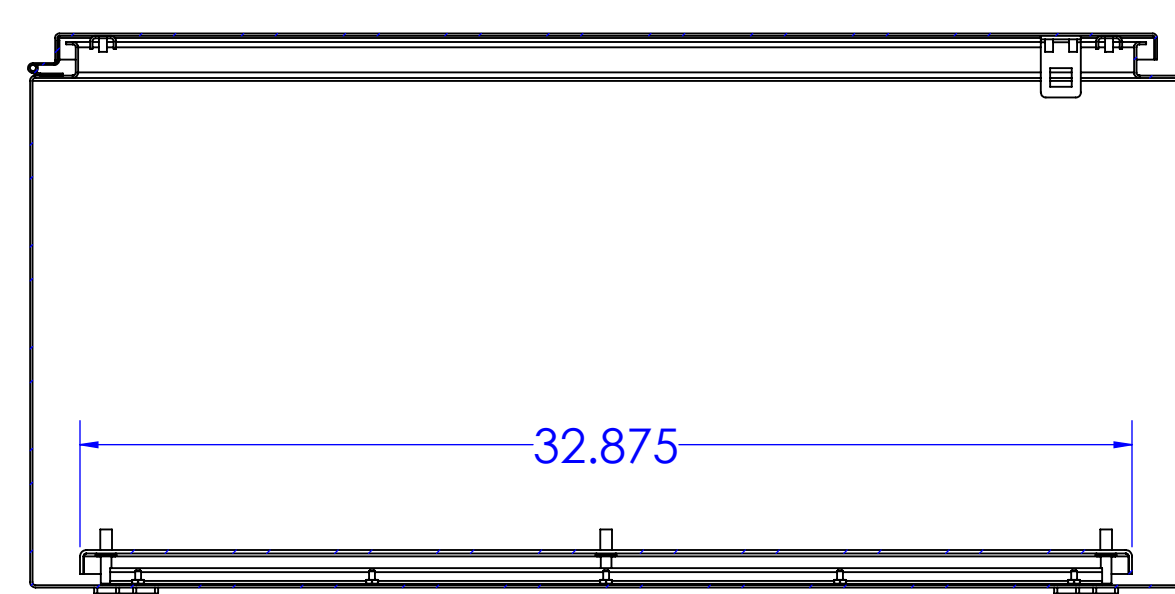
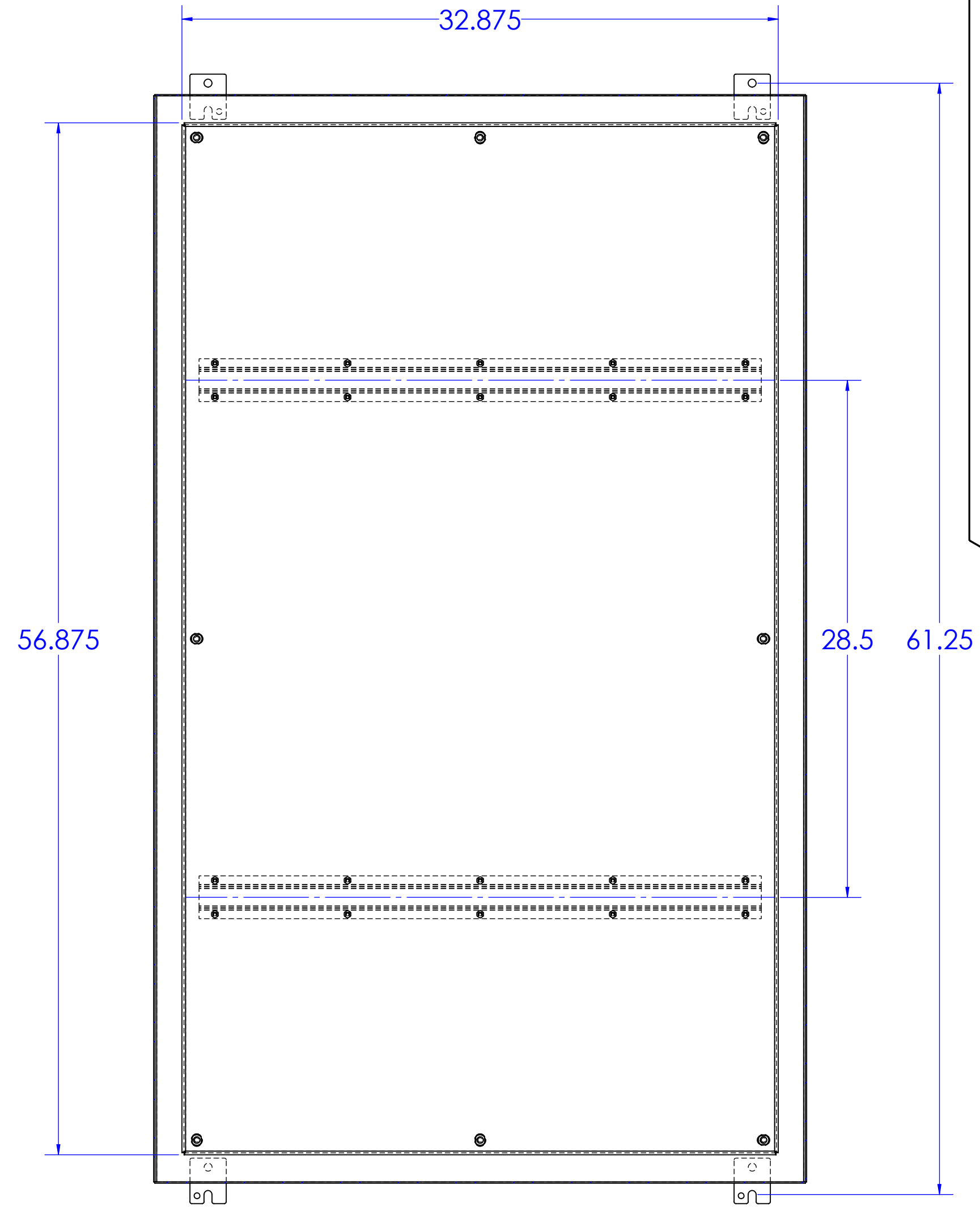
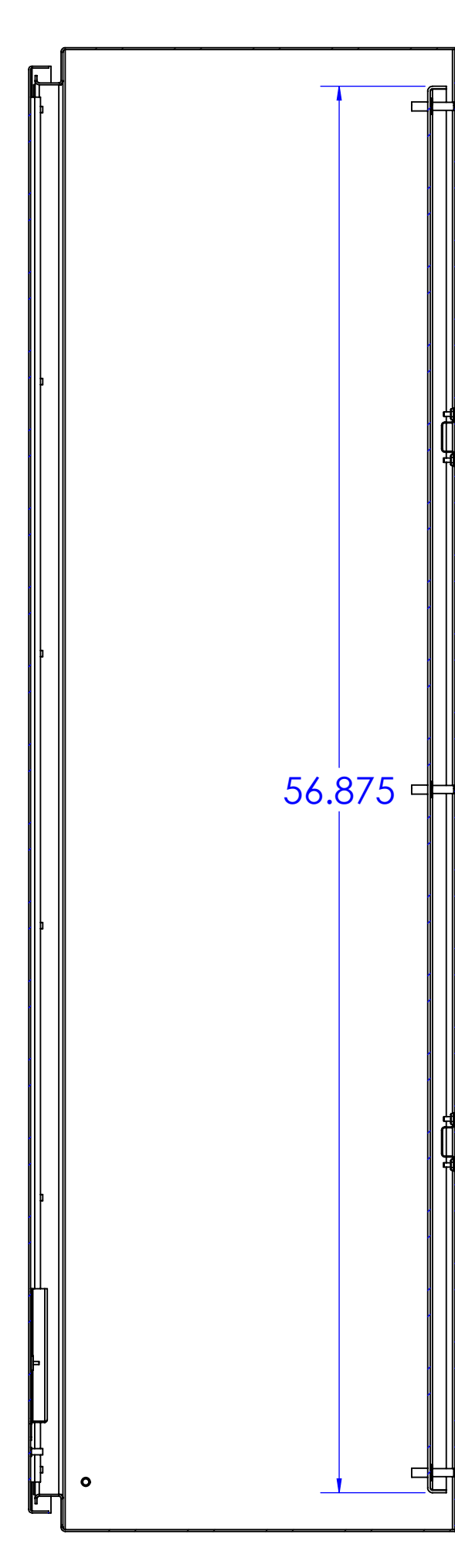
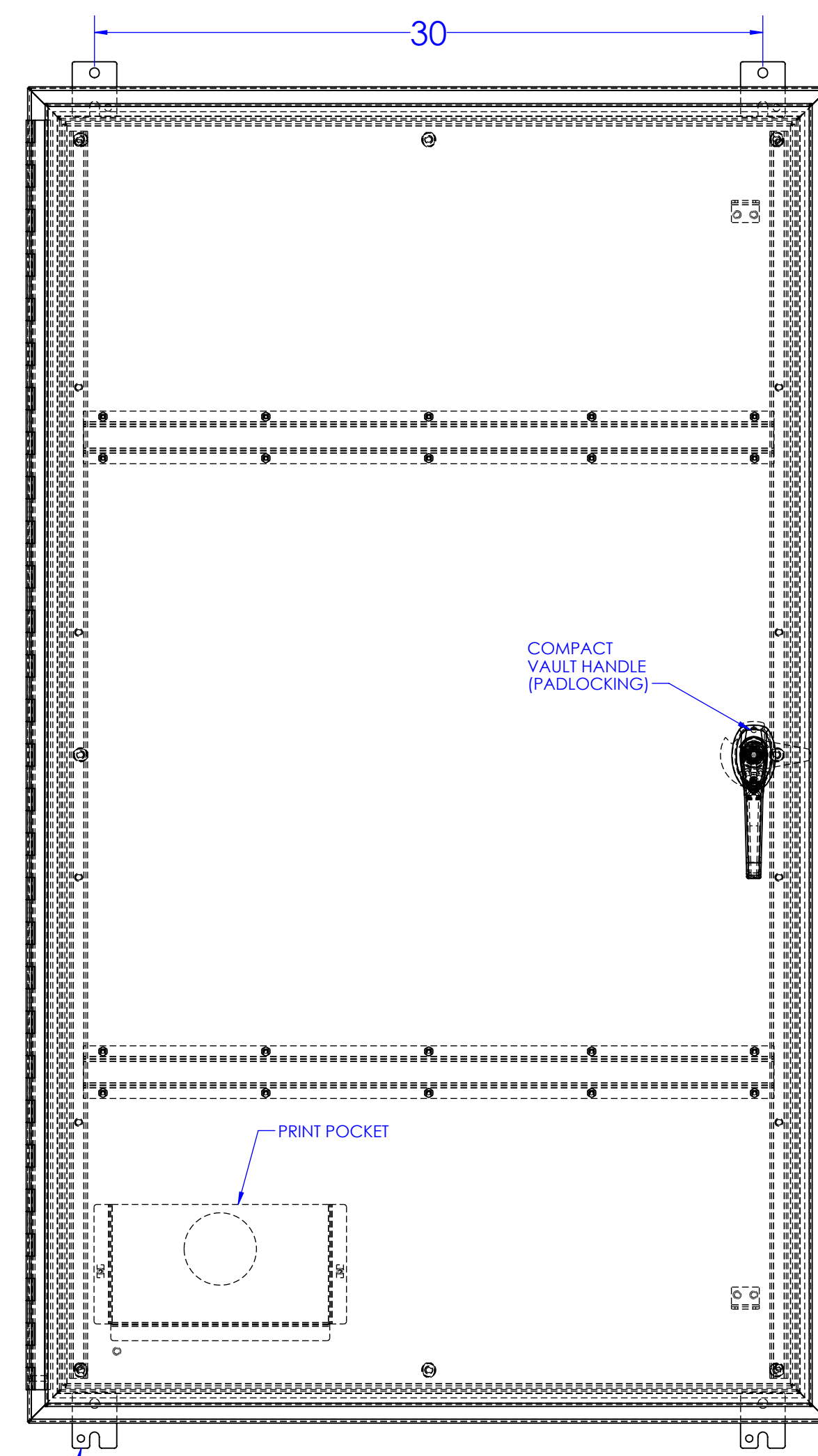
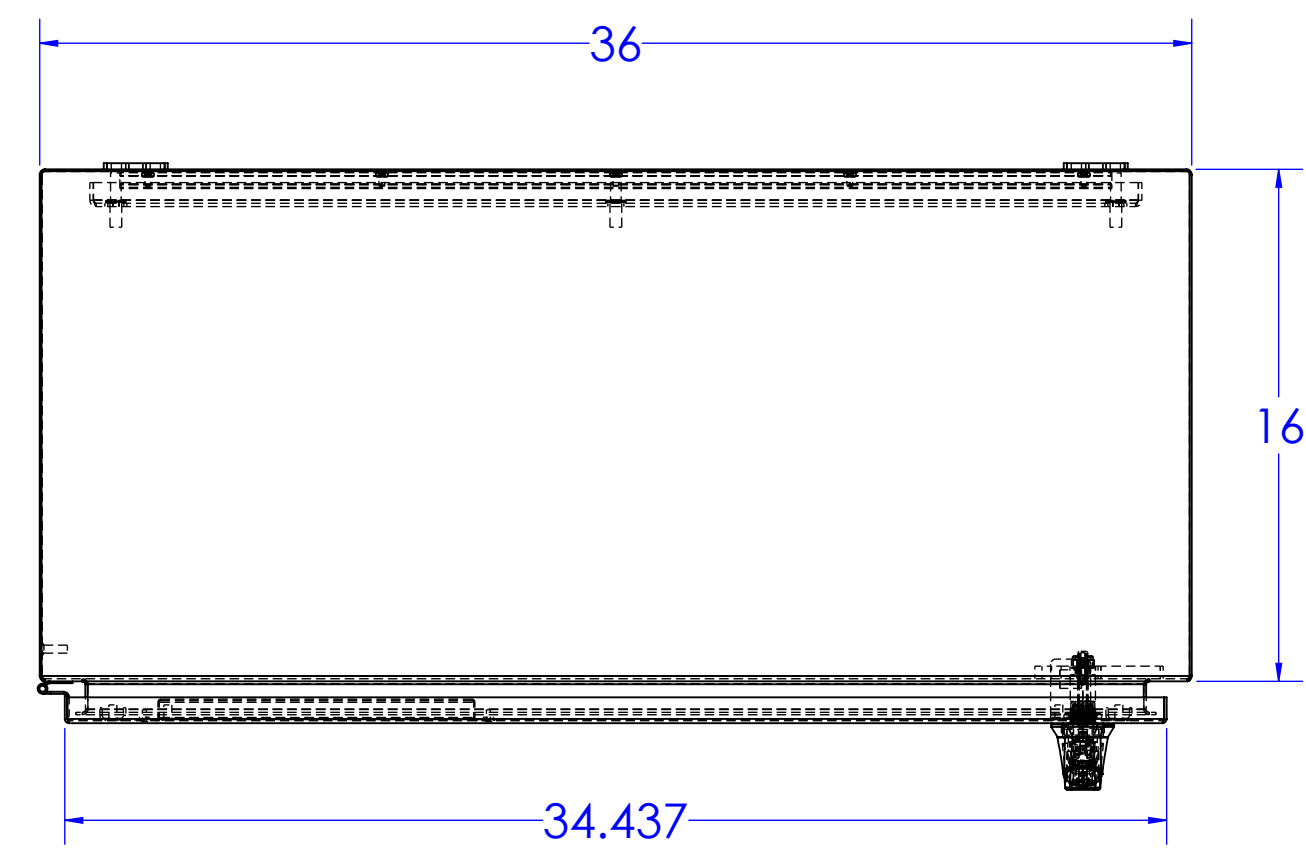
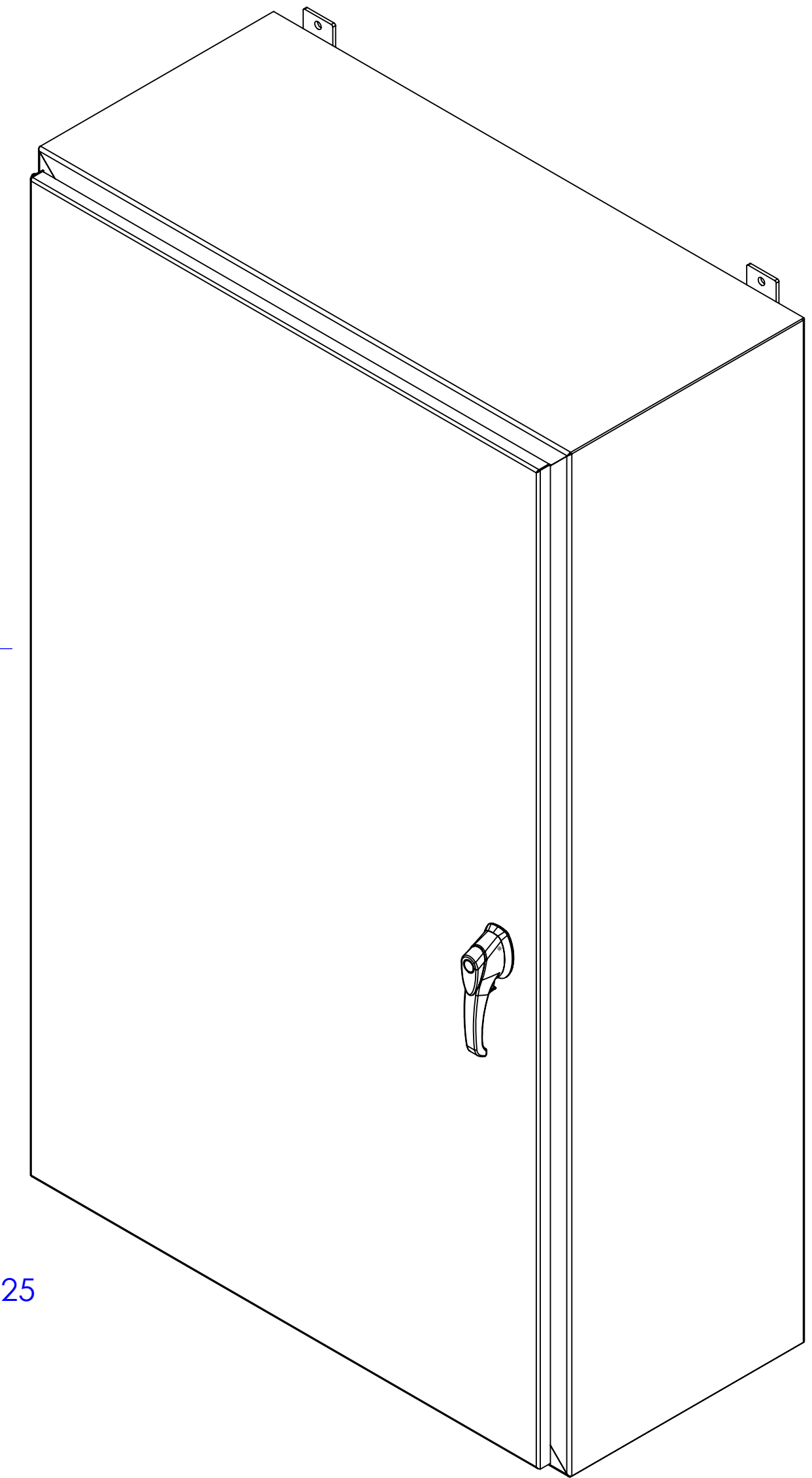

PROPRIETARY AND CONFIDENTIAL
 THE INFORMATION CONTAINED IN THIS DRAWING IS THE SOLE PROPERTY OF RALSTON METAL PRODUCTS. ANY REPRODUCTION OR TRANSMISSION WITHOUT THE WRITTEN PERMISSION OF RALSTON METAL PRODUCTS IS PROHIBITED.

UNLESS OTHERWISE SPECIFIED
 DIMENSIONS ARE IN INCHES
 TOLERANCES:
 FINISHES:
 FINISHES:
 ANGLE AT MATCH 11° REND 1/2°
 ONE PLACE DECIMAL .5"
 TWO PLACE DECIMAL .05"
 THREE PLACE DECIMAL .005"
 UNLESS OTHERWISE SPECIFIED

SEE BOM
 FRST:
 SEE BOM
 DO NOT SCALE DRAWING

NAME	DATE
DRAWN BY: WAYNE STINNETT	2023-12-20
ISSUED BY: WAYNE STINNETT	2023-12-20
JOB ORDER NO.:	

CUSTOMER: **RALSTON STOCK**
 PREPARED BY: **WAYNE STINNETT**

REV. **D** PART NAME: **N43P-SS-603616**

PART NO. **N43P-SS-603616** WEIGHT: 238.711

THIRD ANGLE PROJECTION SCALE: 1:4 SHEET 1 OF 1

