

REVISIONS			
REV.	DESCRIPTION	DATE	APPROVED

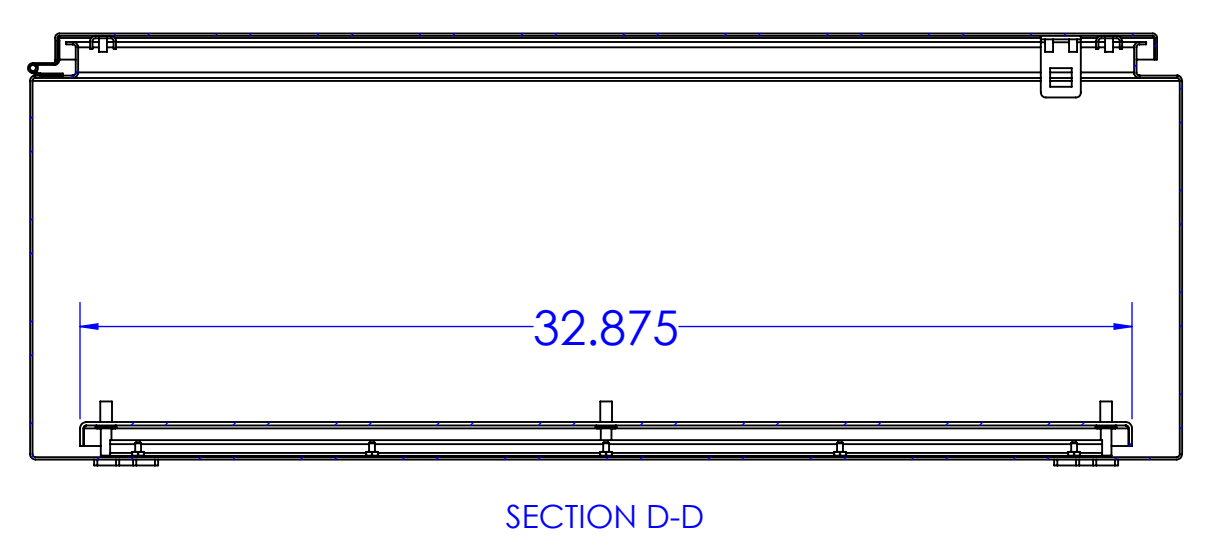
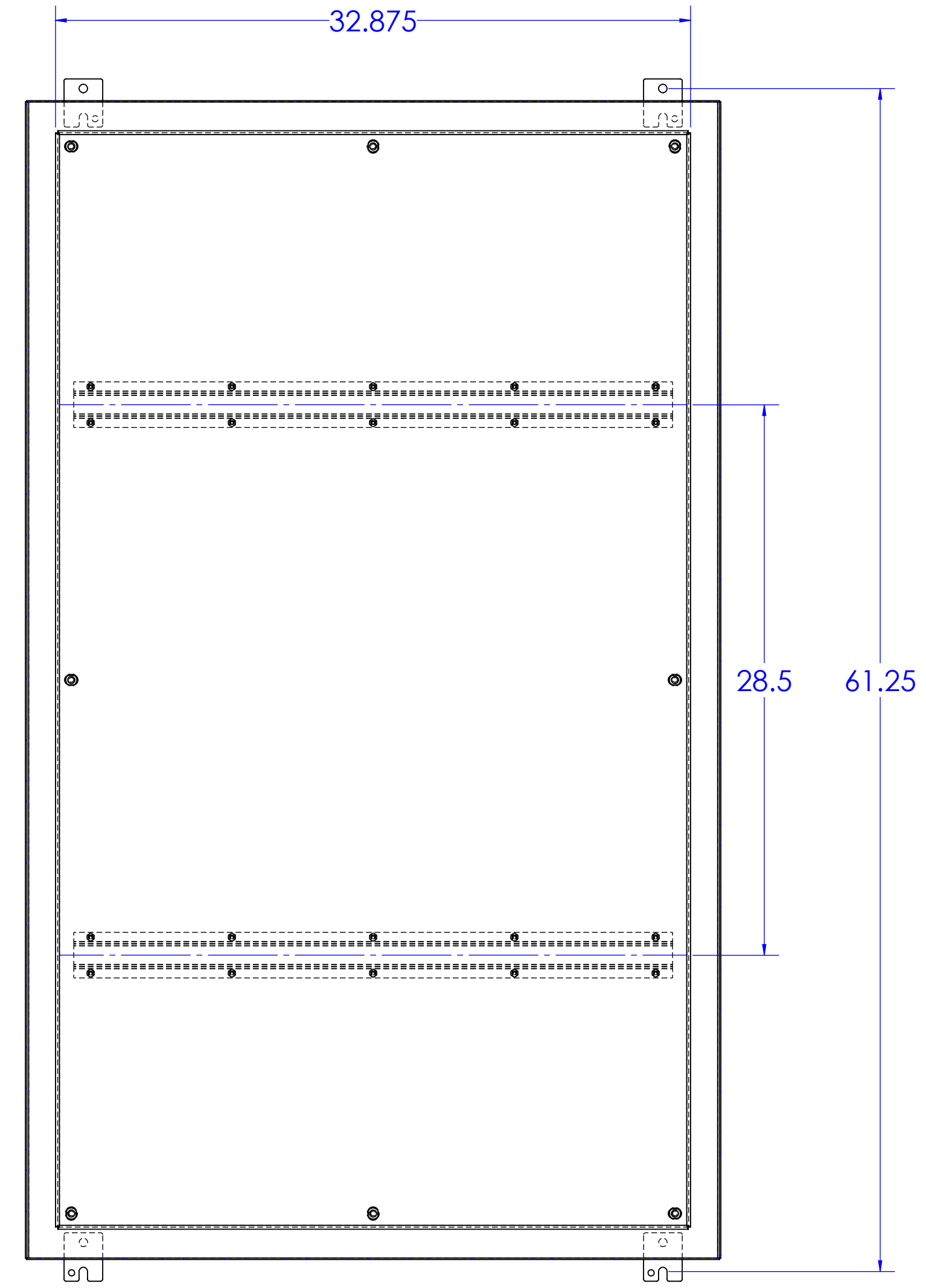
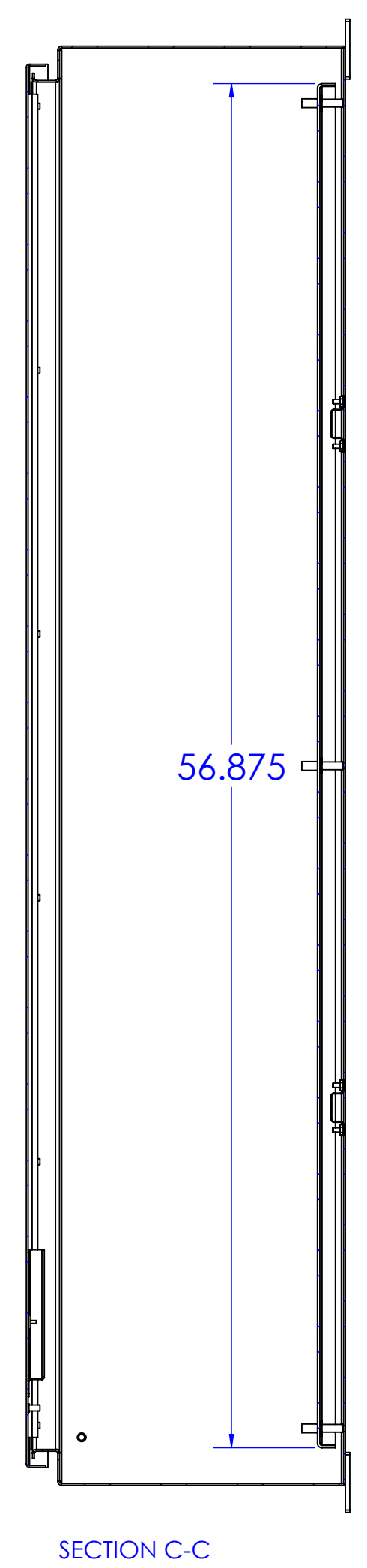
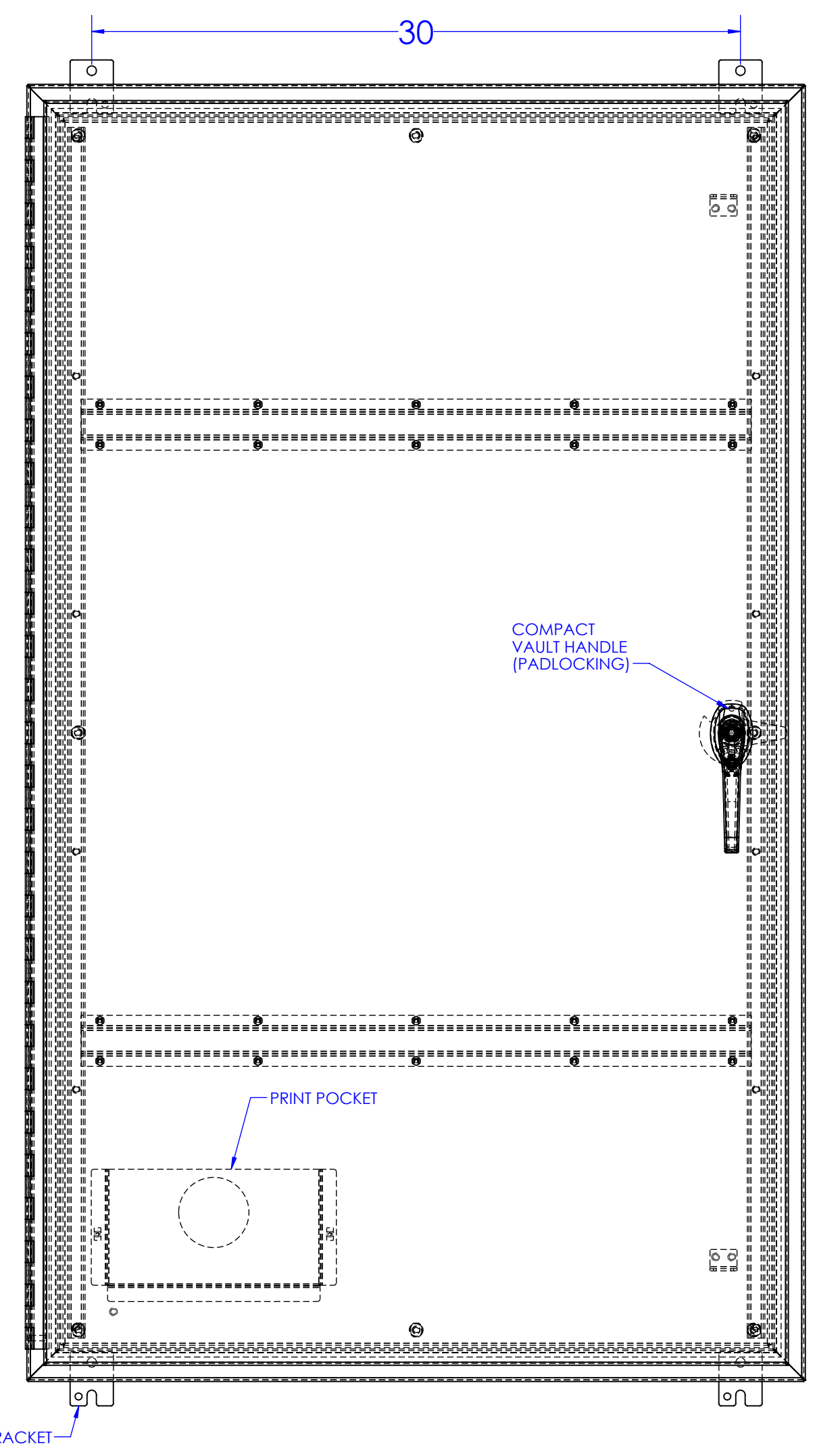
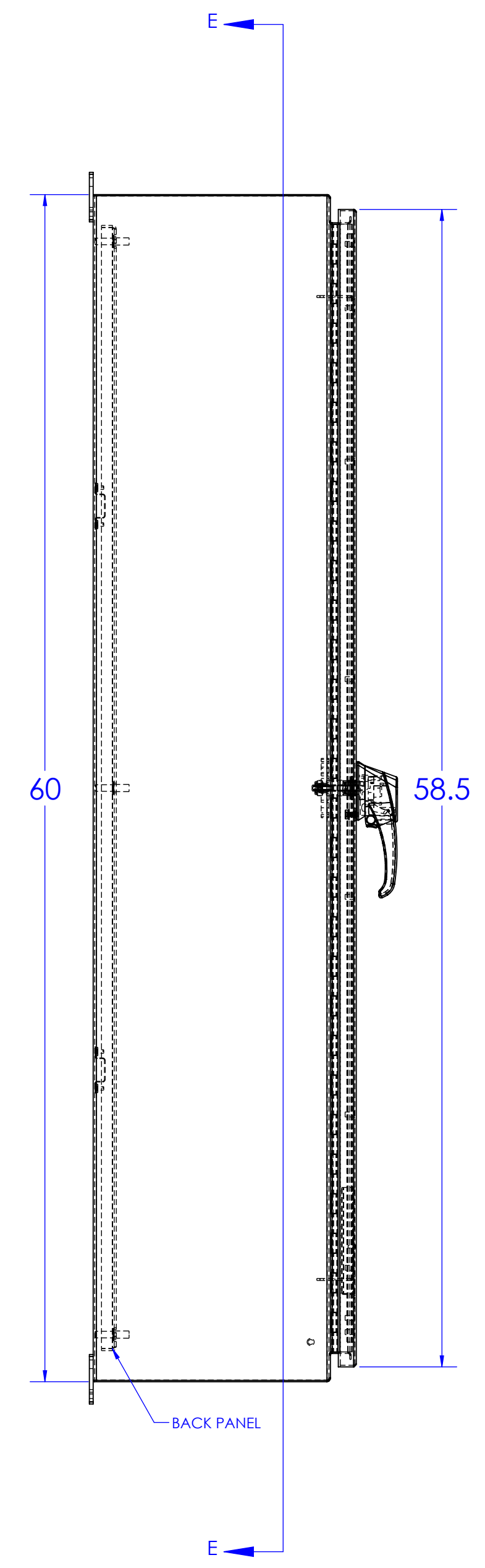
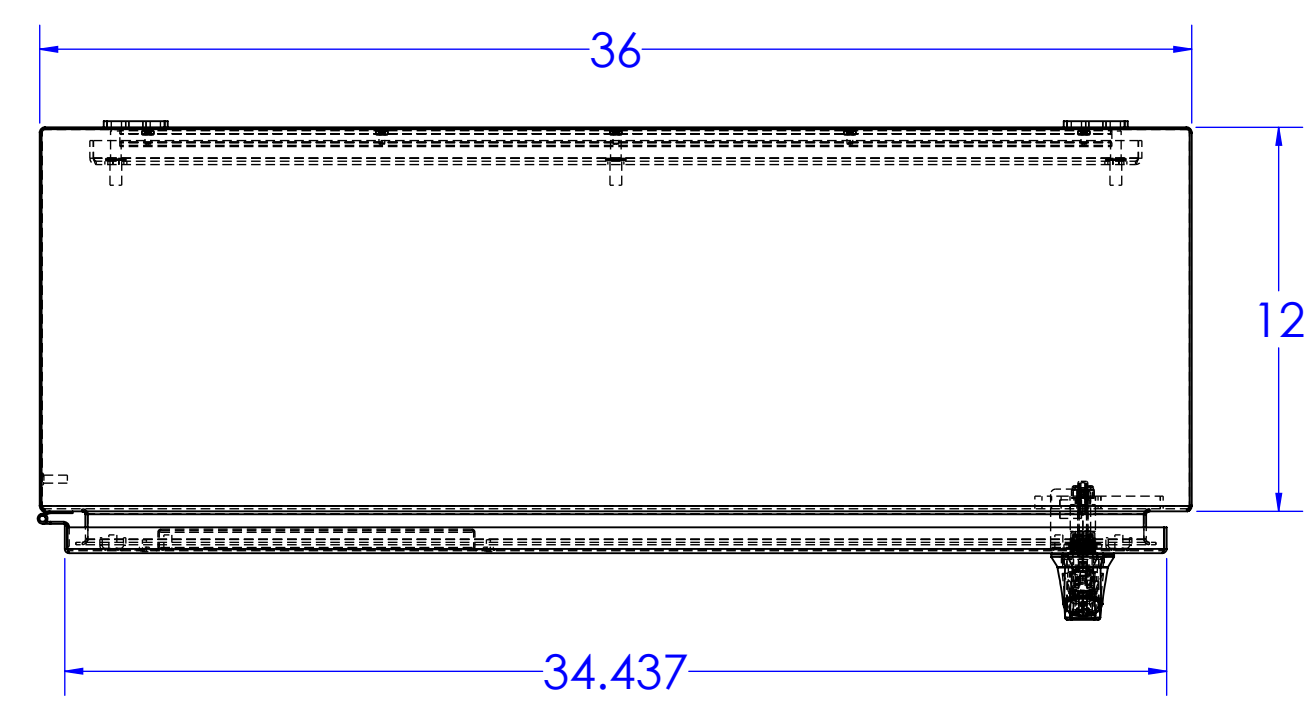
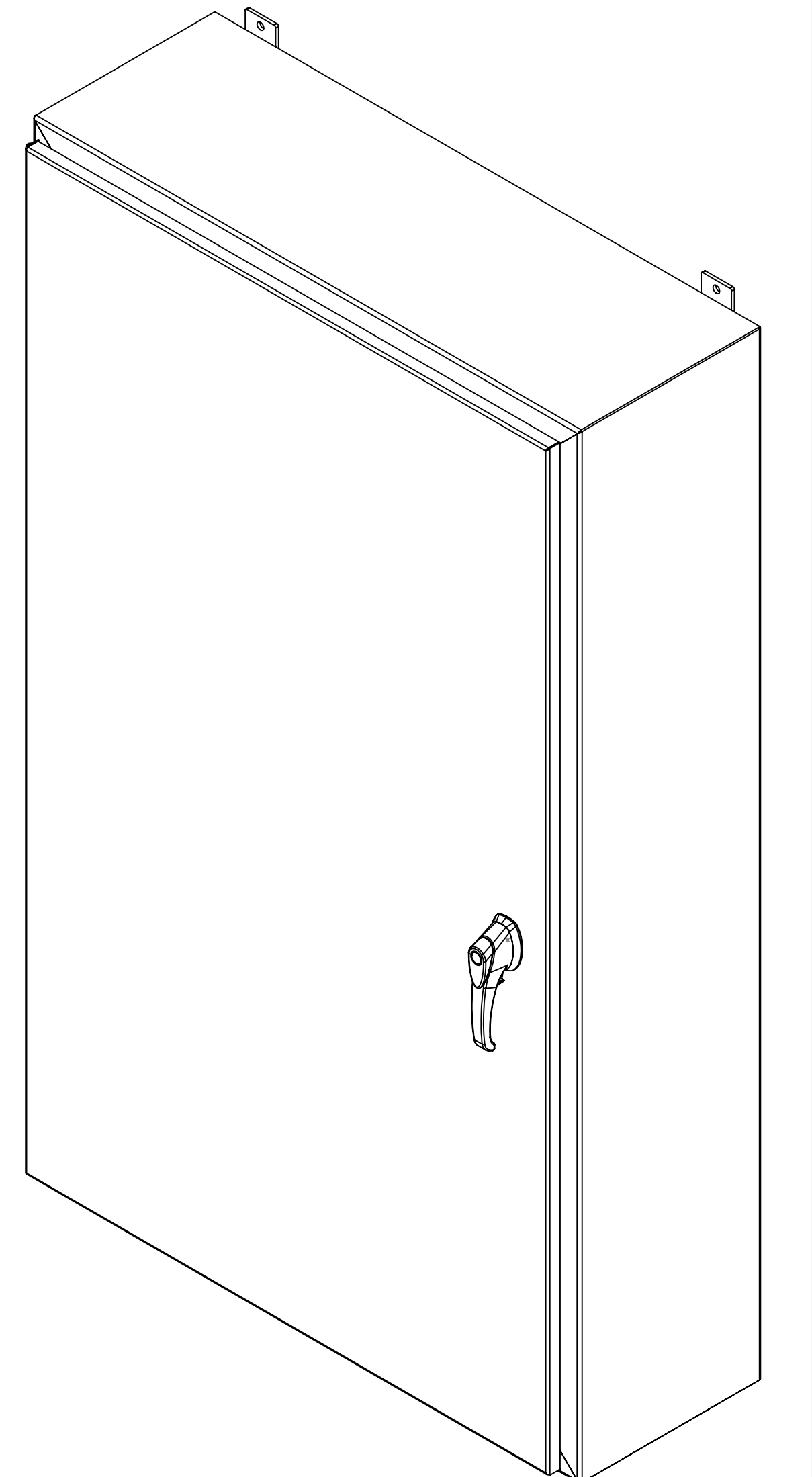

PROPRIETARY AND CONFIDENTIAL
 THE INFORMATION CONTAINED IN THIS DRAWING IS THE SOLE PROPERTY OF RALSTON METAL PRODUCTS. ANY REPRODUCTION OR TRANSMISSION WITHOUT THE WRITTEN PERMISSION OF RALSTON METAL PRODUCTS IS PROHIBITED.

UNLESS OTHERWISE SPECIFIED
 DIMENSIONS ARE IN INCHES
 TOLERANCES:
 FINISHES:
 ANGLES: AS SHOWN
 ONE PLACE DECIMAL
 TWO PLACE DECIMAL
 THIRTY SECOND DECIMAL
 FURFILL

SEE BOM
 FRST:
 SEE BOM
 DO NOT SCALE DRAWING

NAME	DATE
DRAWN BY: WAYNE STRODT	2023-12-20
ISSUED BY: WAYNE STRODT	2023-12-20
JOB ORDER NO.:	

CUSTOMER: RALSTON STOCK
 PROPRIETARY NUMBER:

SEE PART NAME: **D** N43P-SS-603612
 PART NO. N43P-SS-603612
 SCALE: 1:4
 WEIGHT: 222.107
 SHEET 1 OF 1

Ralston
 Metal Products Limited
 15 WESTON ROAD
 GUILFORD, ONTARIO, M7L 1E3
 PHONE: (905) 886-1000
 FAX: (905) 886-1011
 WWW.RALSTONMETAL.COM