

REVISIONS			
REV.	DESCRIPTION	DATE	APPROVED

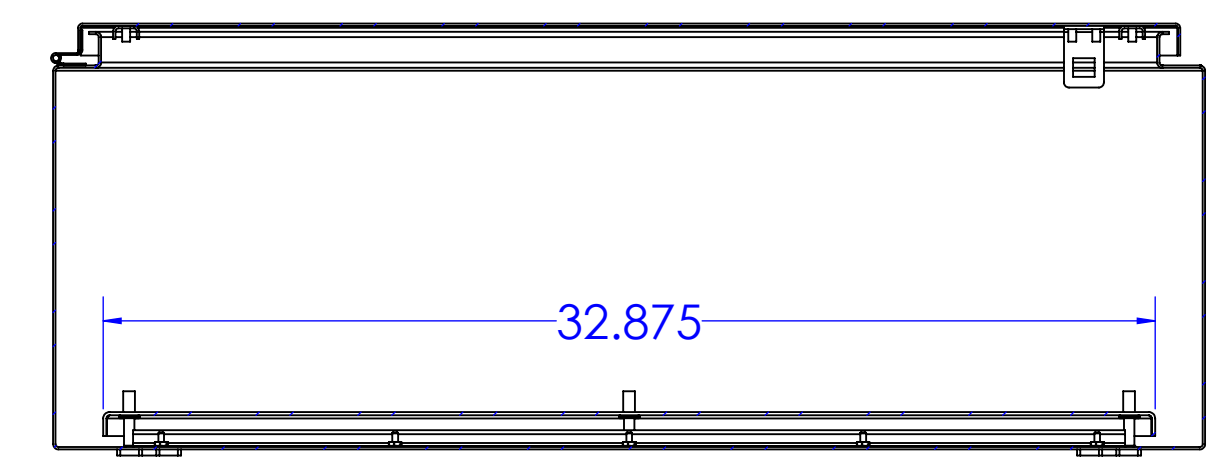
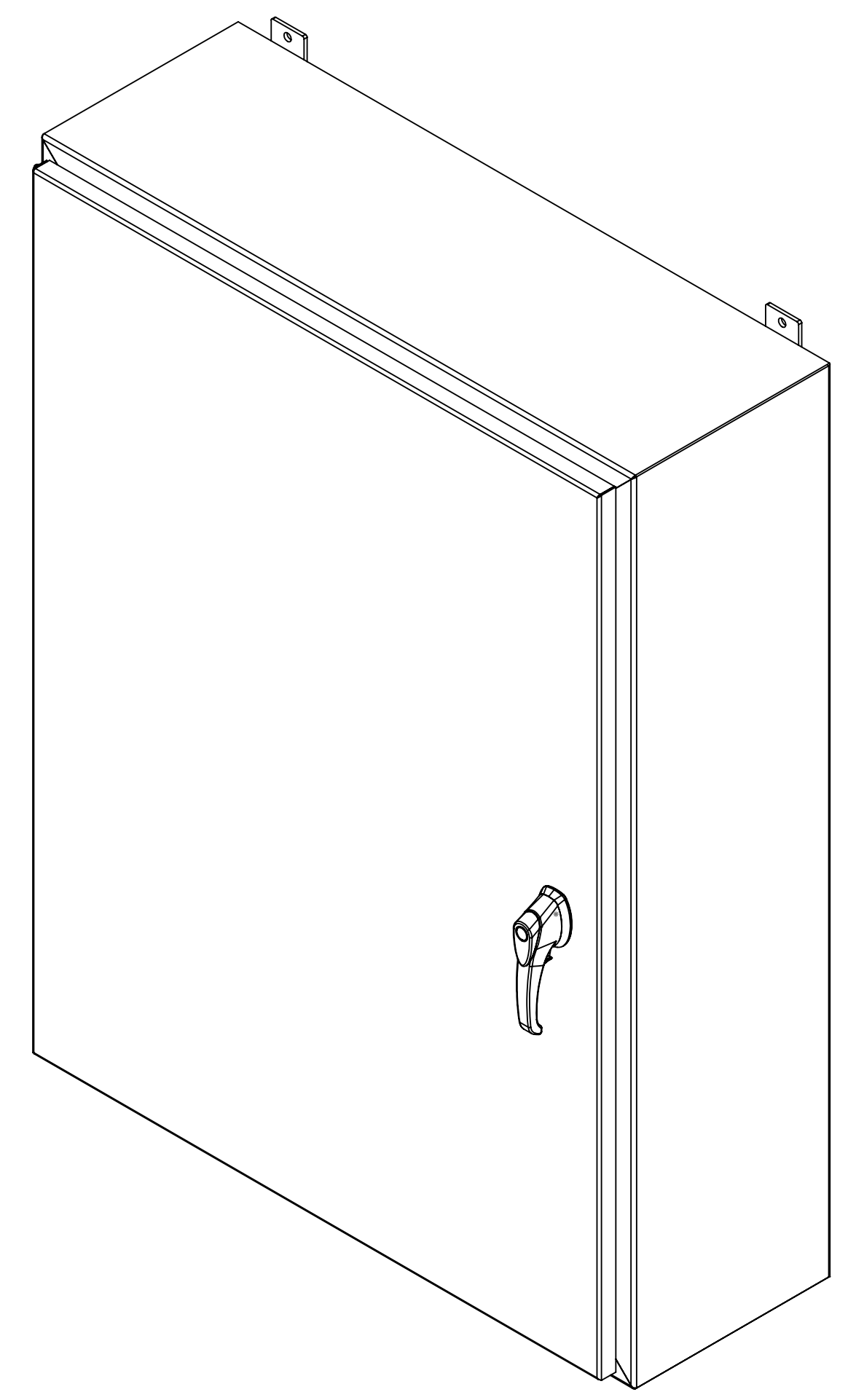
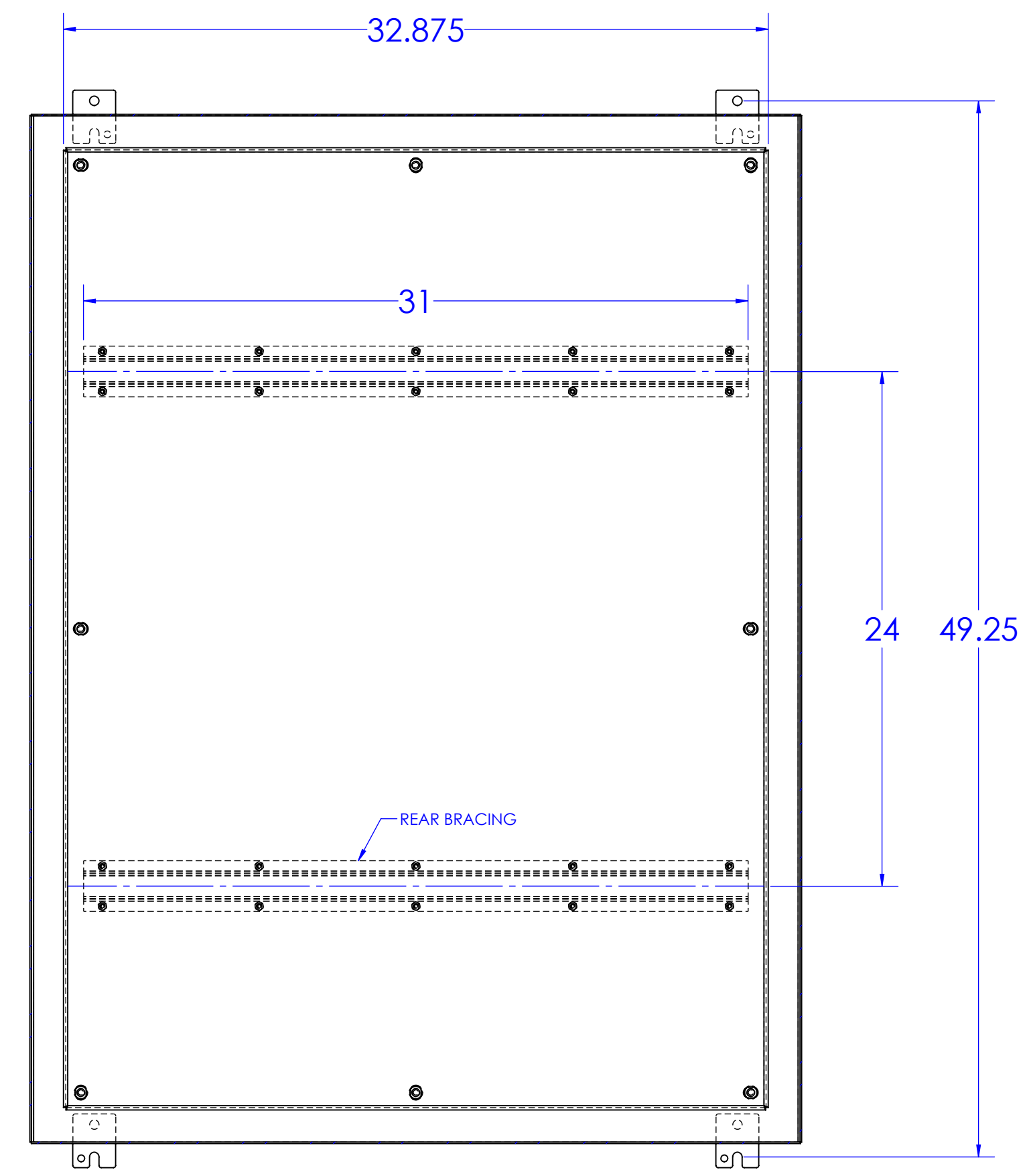
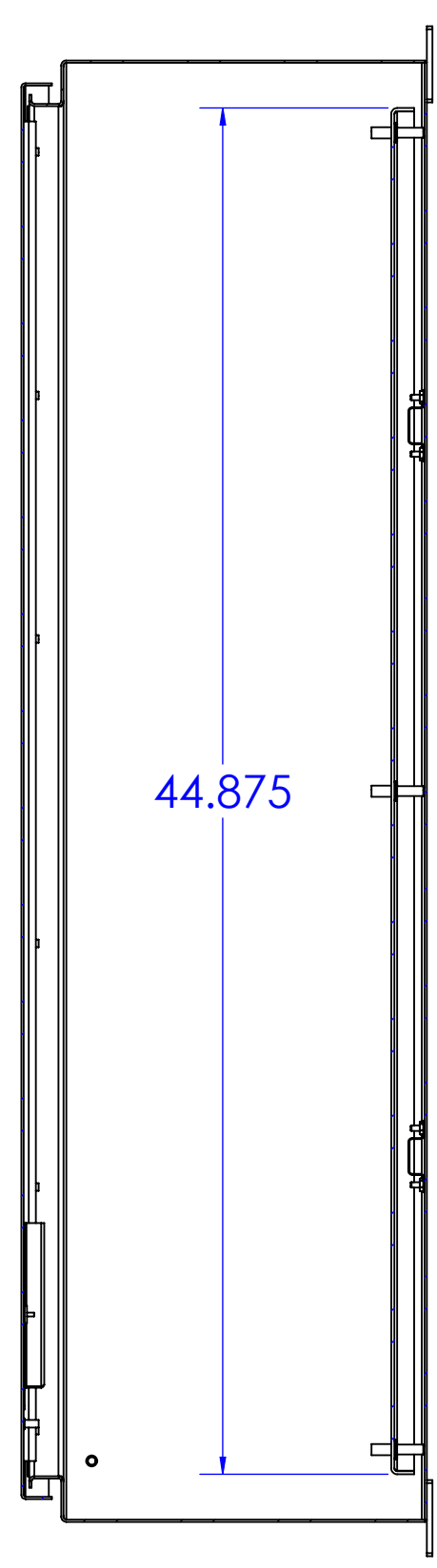
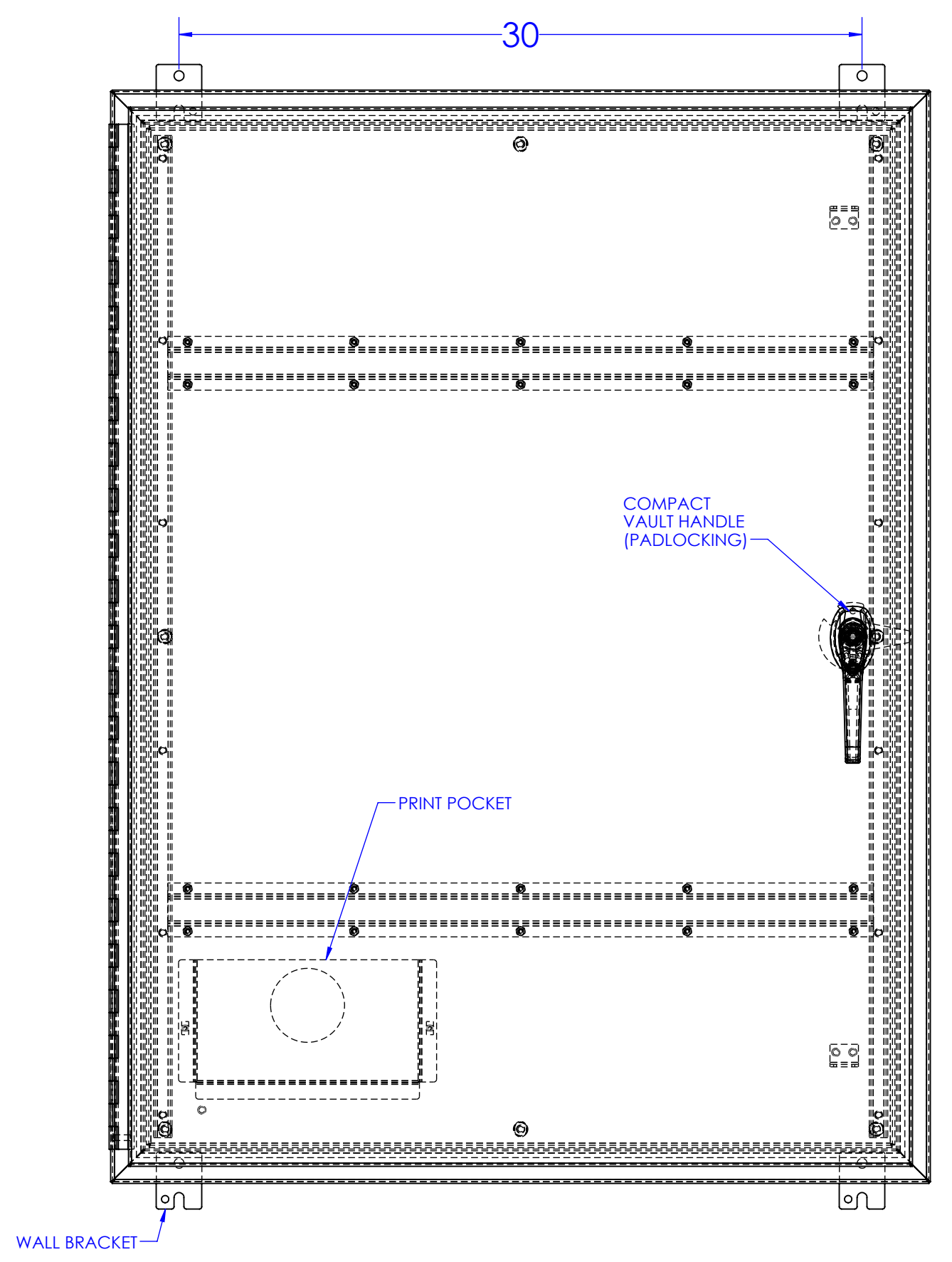
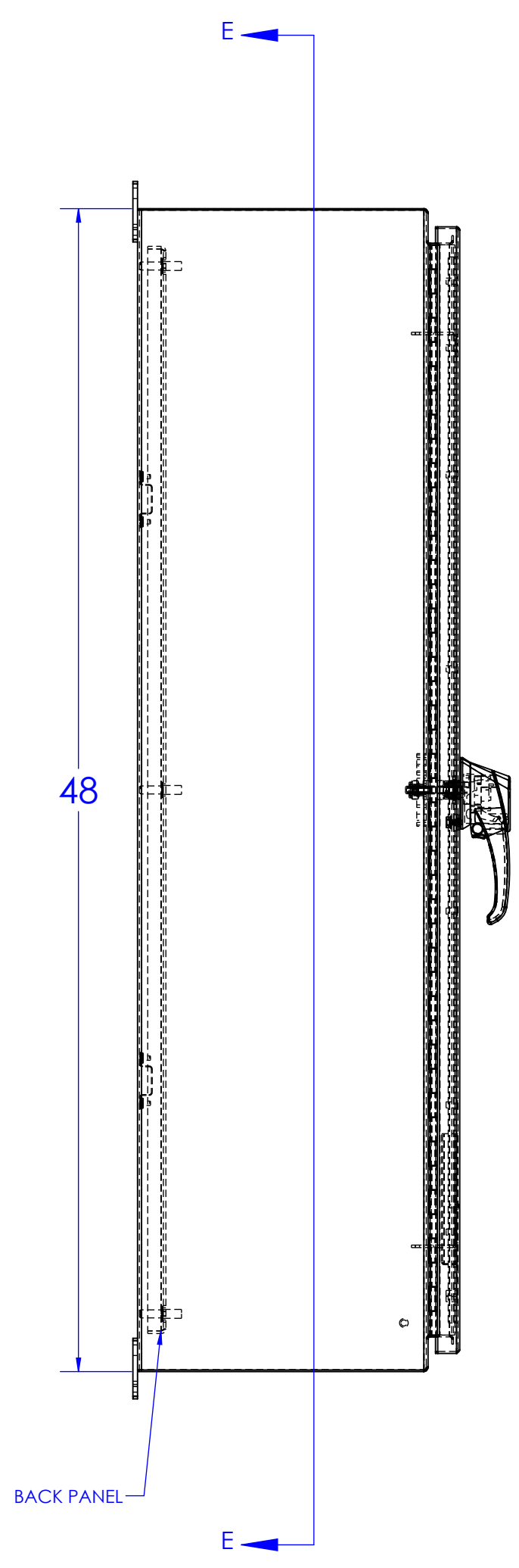
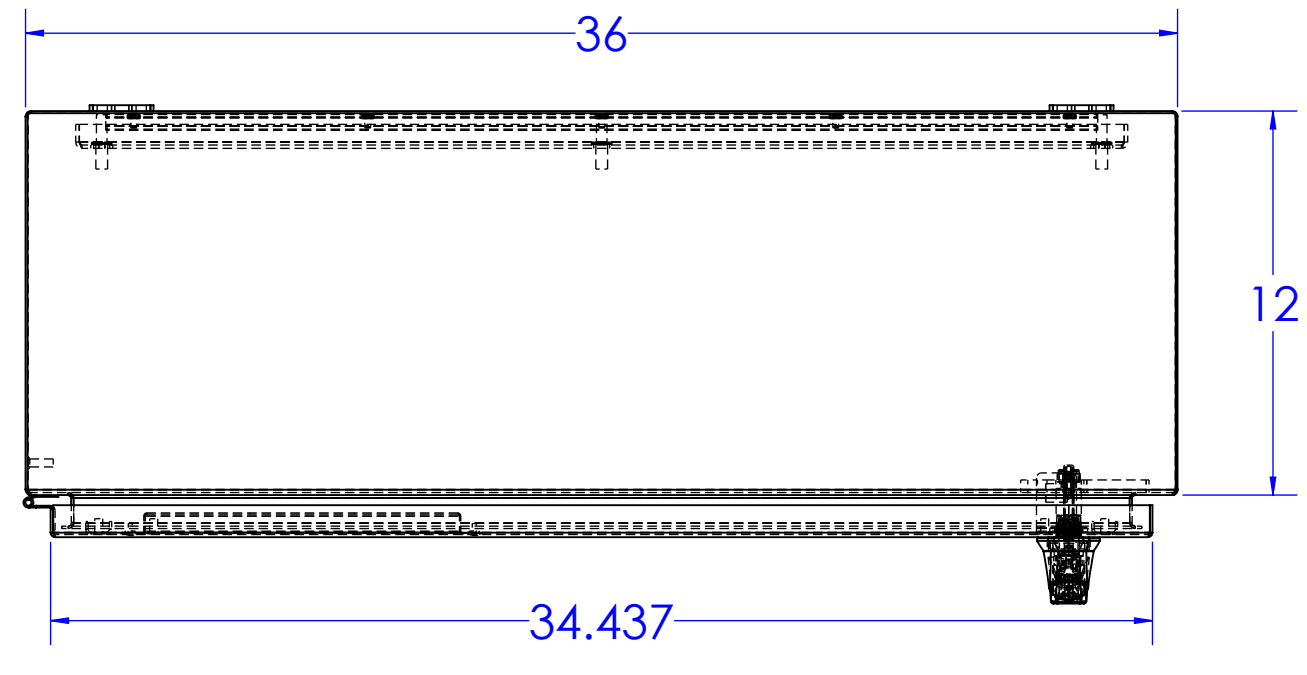

PROPRIETARY AND CONFIDENTIAL
 THE INFORMATION CONTAINED IN THIS DRAWING IS THE SOLE PROPERTY OF RALSTON METAL PRODUCTS. ANY REPRODUCTION OR TRANSMISSION WITHOUT THE WRITTEN PERMISSION OF RALSTON METAL PRODUCTS IS PROHIBITED.

UNLESS OTHERWISE SPECIFIED
 DIMENSIONS ARE IN INCHES
 TOLERANCES:
 FINISH: TO MATCH
 ANGLE: AS SHOWN
 ONE PLACE DECIMAL
 TWO PLACE DECIMAL
 THREE PLACE DECIMAL
 FOUR PLACE DECIMAL
 FIVE PLACE DECIMAL
 SIX PLACE DECIMAL
 SEVEN PLACE DECIMAL
 EIGHT PLACE DECIMAL
 NINE PLACE DECIMAL
 TEN PLACE DECIMAL

SEE BOM
 FRUIT
 SEE BOM
 DO NOT SCALE DRAWING

NAME	DATE
DRAWN BY: WAYNE STINNETT	2023-12-20
ISSUED BY: WAYNE STINNETT	2023-12-20
JOB ORDER NO:	

CUSTOMER: RALSTON STOCK
 PREPARED BY: JAMES

SCALE: 1:1
 WEIGHT: 183.009
 SHEET 1 OF 1

Ralston
 Metal Products Limited
 15 WESTON ROAD
 GUILDFORD ONTARIO N4L 1B2
 PHONE: 519-848-0888
 TOLL FREE: 1-800-365-9111
 FAX: 519-848-0891
 WWW.RALSTONMETAL.COM

SEE: PART NAME: **D N43P-SS-483612**
 PART NO.: N43P-SS-483612
 SCALE: 1:1
 WEIGHT: 183.009
 SHEET 1 OF 1