

REVISIONS			
REV.	DESCRIPTION	DATE	APPROVED

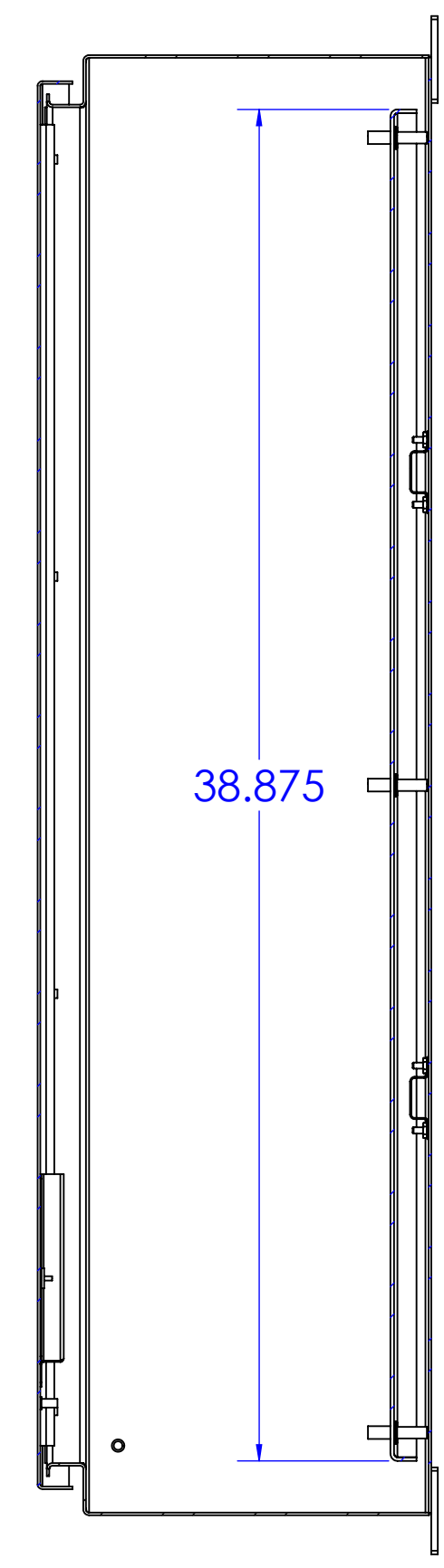

SECTION C-C

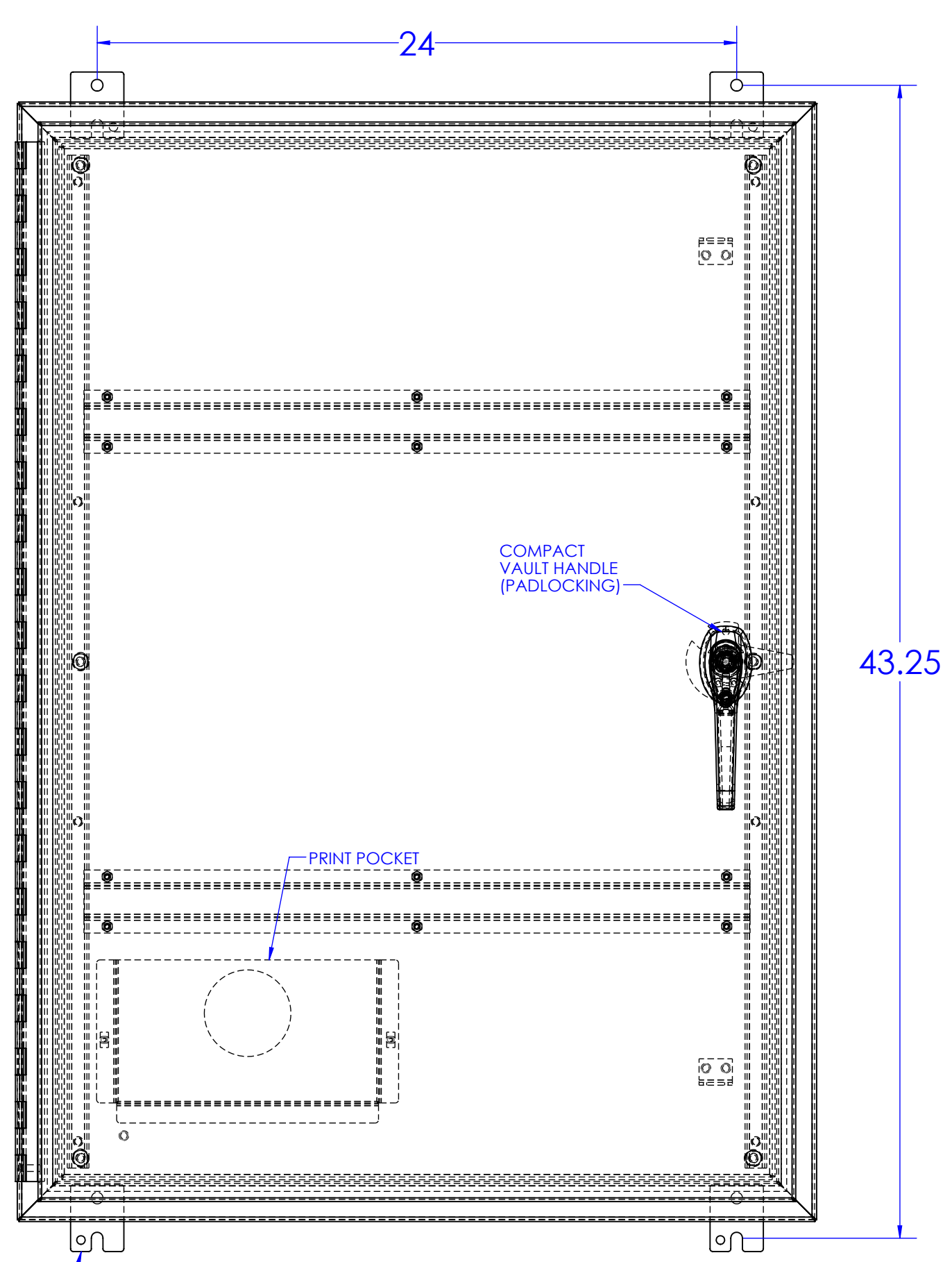
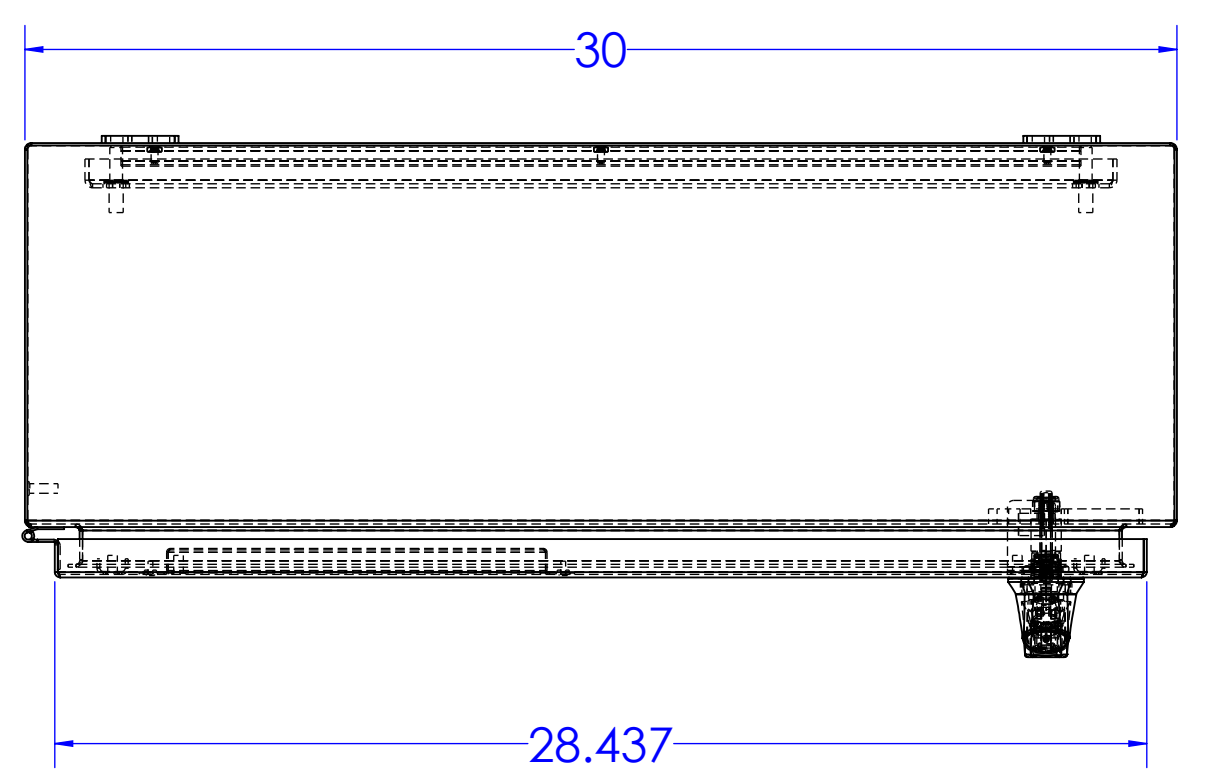
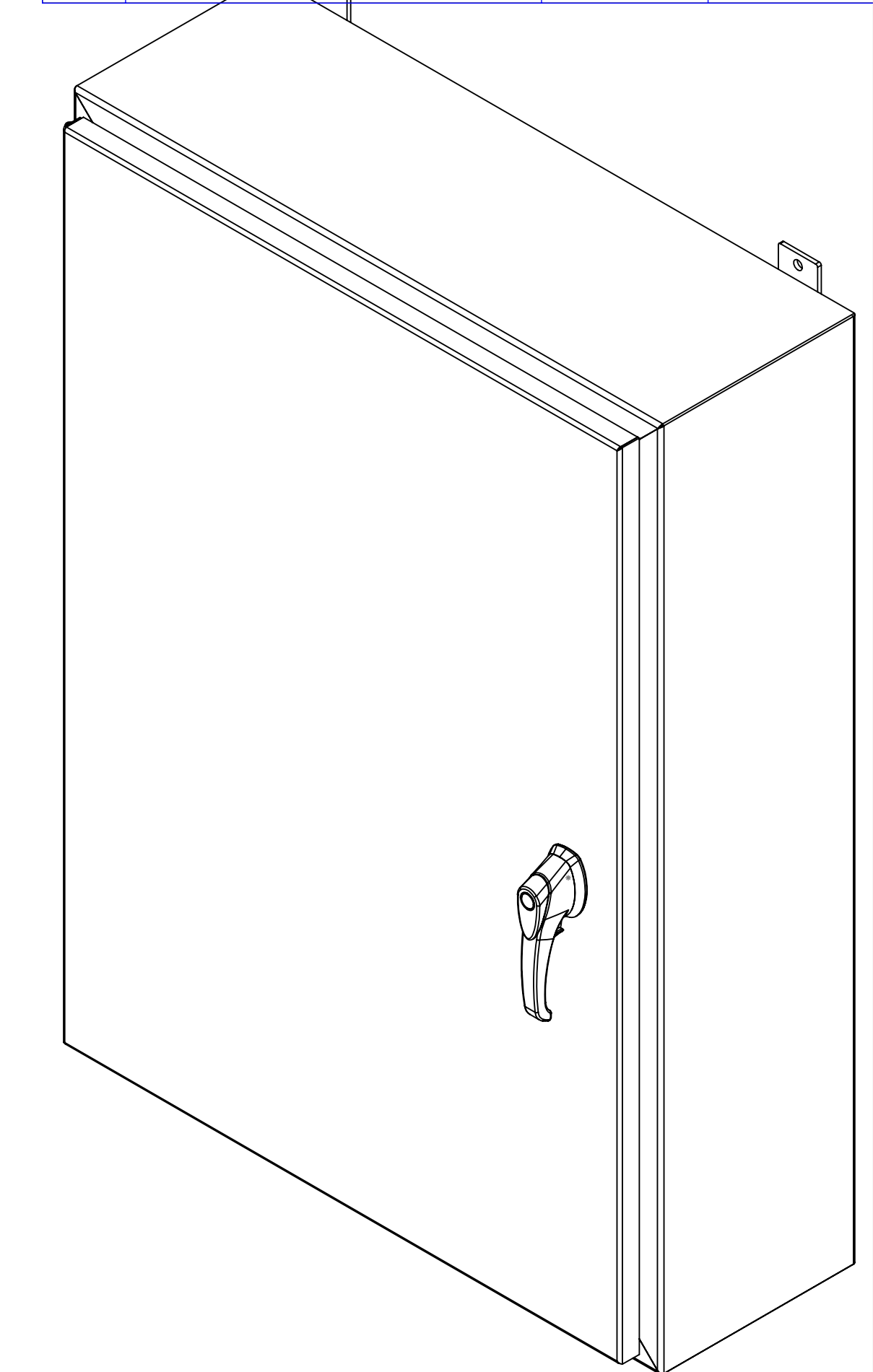
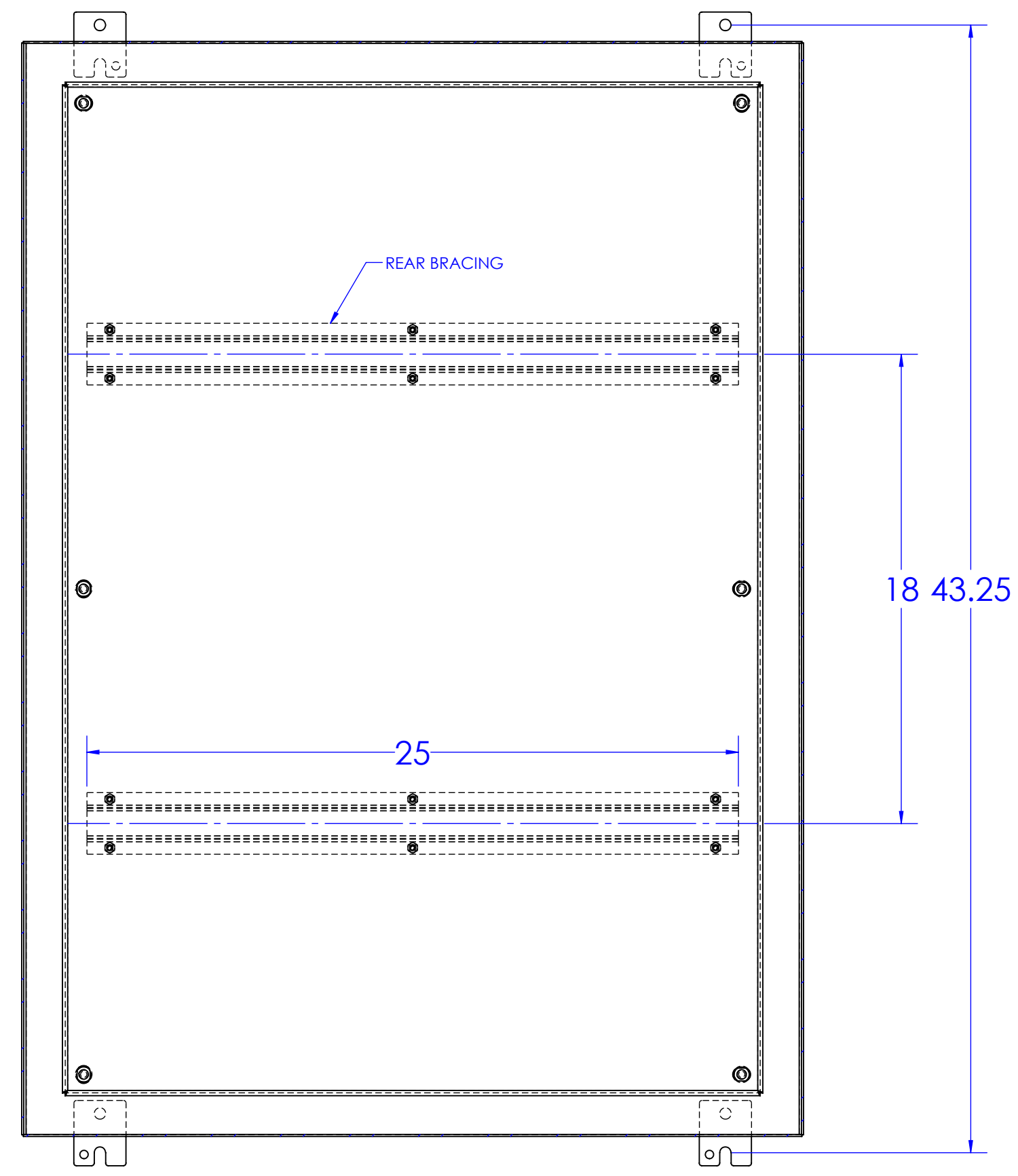

SECTION E-E

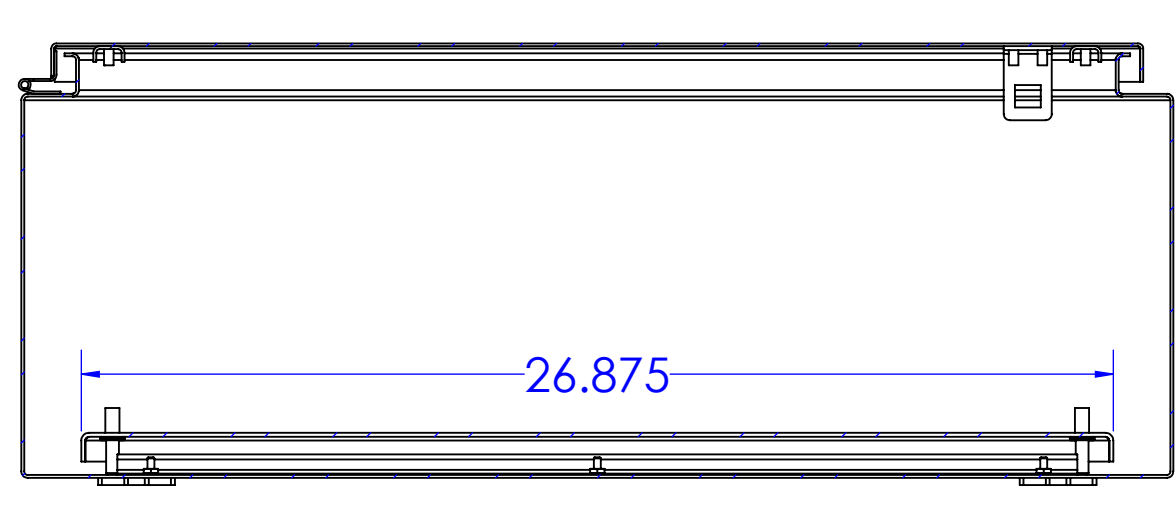

SECTION D-D

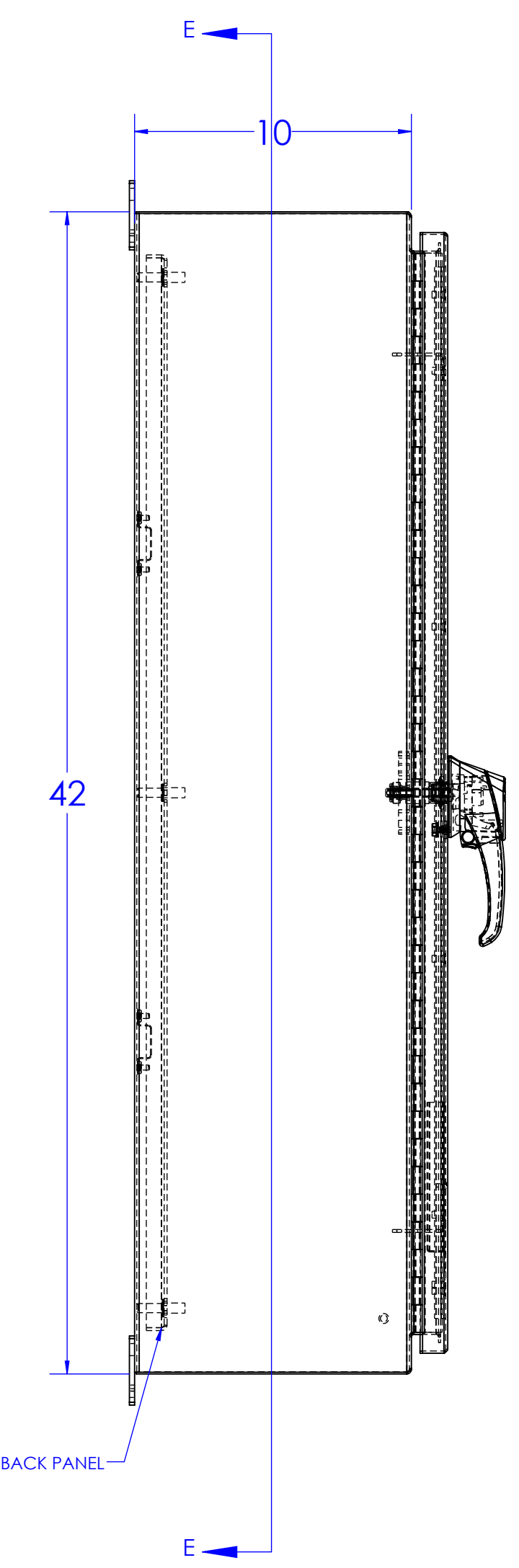

BACK PANEL

PROPRIETARY AND CONFIDENTIAL
 THE INFORMATION CONTAINED IN THIS DRAWING IS THE SOLE PROPERTY OF RALSTON METAL PRODUCTS. ANY REPRODUCTION OR TRANSMISSION OF THIS DRAWING WITHOUT THE WRITTEN PERMISSION OF RALSTON METAL PRODUCTS IS PROHIBITED.

UNLESS OTHERWISE SPECIFIED
 DIMENSIONS ARE IN INCHES
 TOLERANCES:
 FINISH: TO BE DETERMINED
 ANGULAR MATCH: 1/32"
 ONE PLACE DECIMAL: ±0.1"
 TWO PLACE DECIMAL: ±0.05"
 THREE PLACE DECIMAL: ±0.010"

SEE BOM
 FRUIT
 SEE BOM
 DO NOT SCALE DRAWING

NAME	DATE
DRAWN BY: WAYNE STINNETT	2023-12-20
ISSUED BY: WAYNE STINNETT	2023-12-20
JOB ORDER NO.:	

CUSTOMER: **RALSTON STOCK**
 PROPRIETARY NUMBER:

REV.:

D N43P-SS-423010

PART NO. N43P-SS-423010
 SCALE: 1:5 WEIGHT: 134.615 SHEET 1 OF 1

Ralston
 Metal Products Limited
 10 WESTON ROAD
 GUILFORD, ONTARIO N1L 1E3
 PHONE: 519-886-0888
 TOLL FREE: 1-800-365-9111
 FAX: 519-886-0891
 WWW.RALSTONMETAL.COM