

REVISIONS			
REV.	DESCRIPTION	DATE	APPROVED

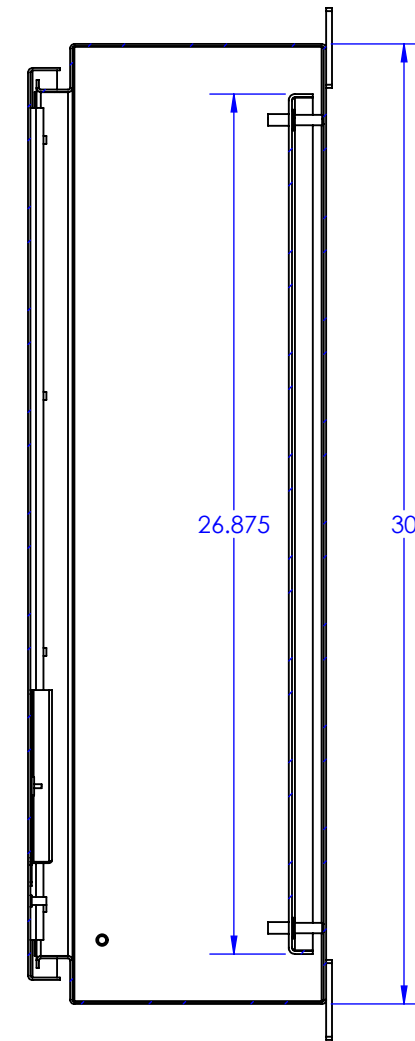

SECTION C-C

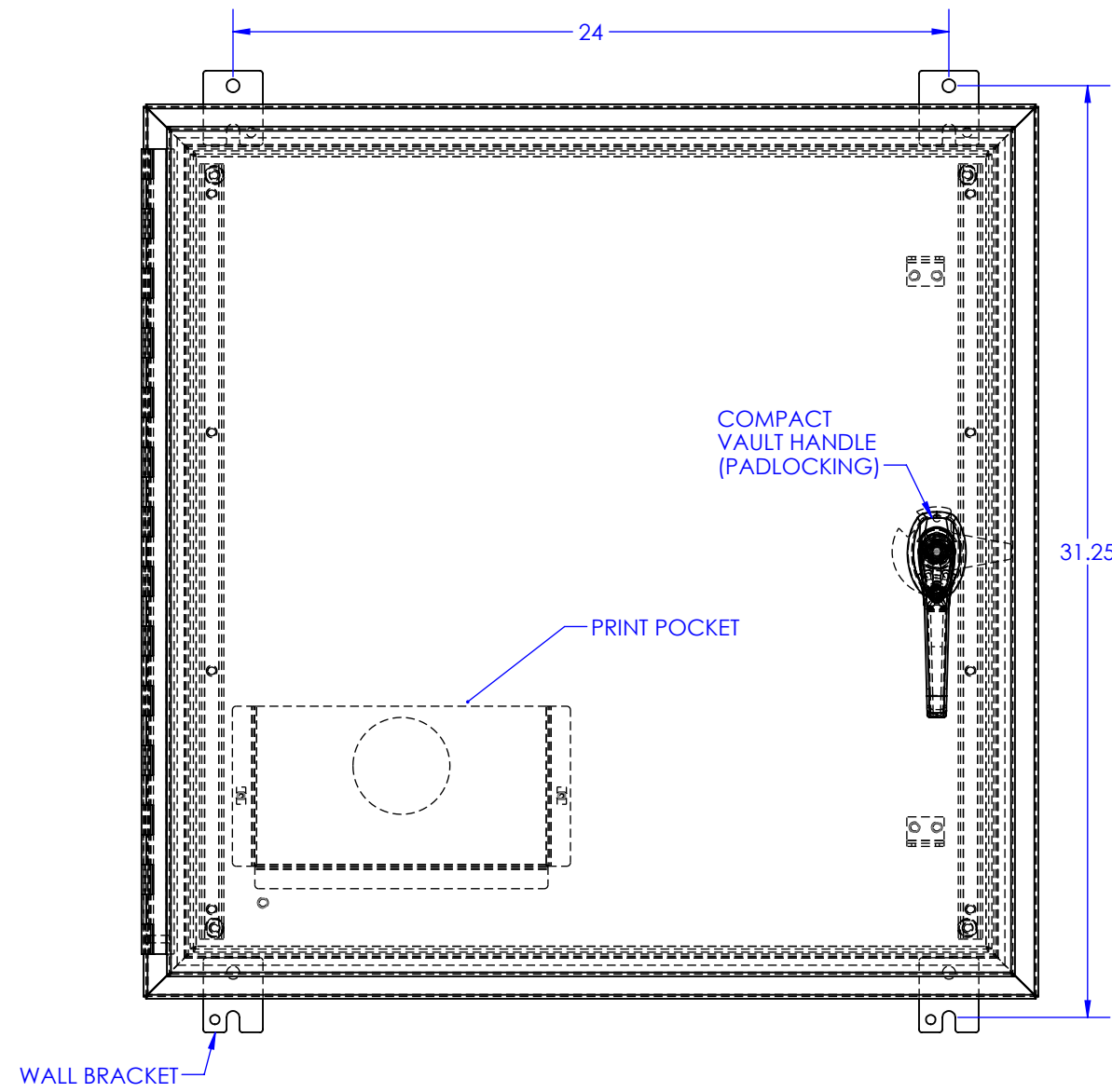
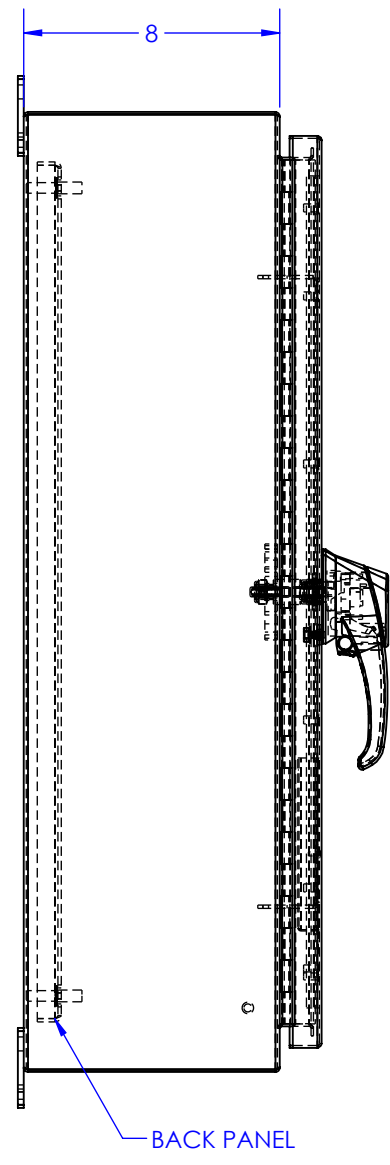
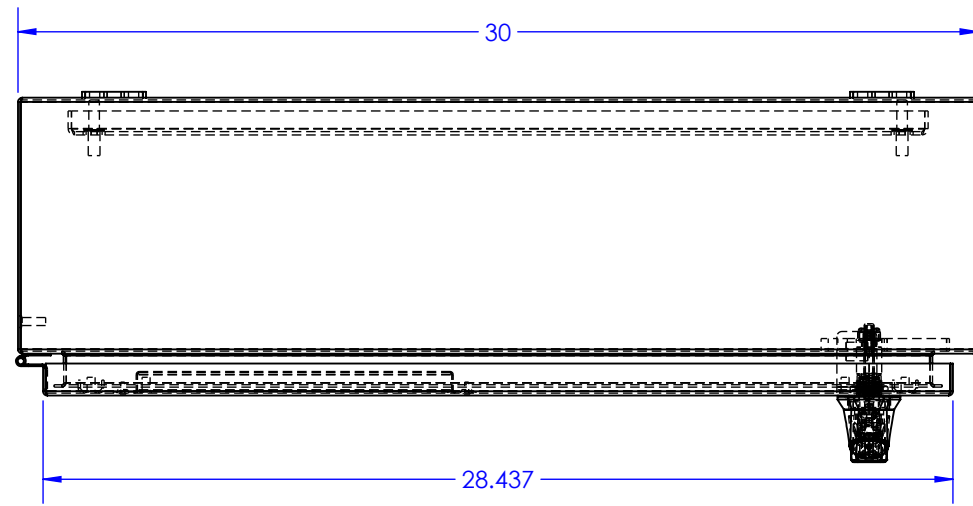
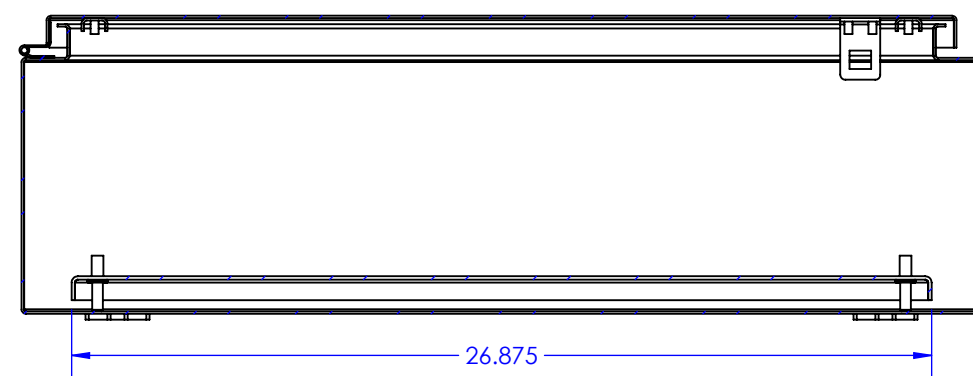

SECTION D-D

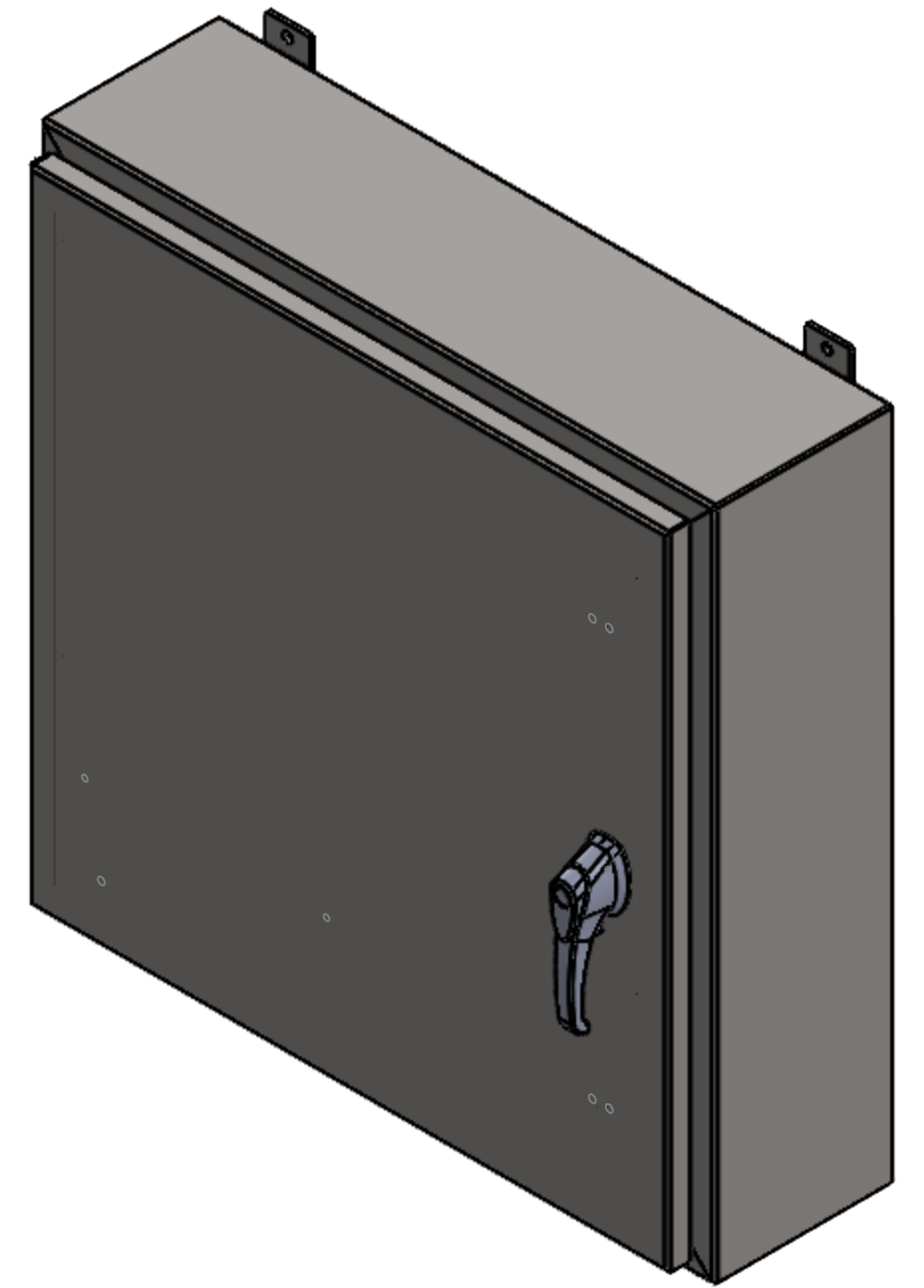

PROPRIETARY AND CONFIDENTIAL THE INFORMATION CONTAINED IN THIS DRAWING IS THE SOLE PROPERTY OF RALSTON METAL PRODUCTS. ANY REPRODUCTION IN PART OR AS A WHOLE WITHOUT THE WRITTEN PERMISSION OF RALSTON METAL PRODUCTS IS PROHIBITED.		NAME	DATE	 <small>50 WATSON ROAD QUELPS, ONTARIO N7L 1E2 PHONE: (519) 836-2969 TOLL FREE: 1-800-265-7611 FAX: (519) 836-9793</small>
<small>DIMENSIONS ARE IN INCHES TOLERANCES: FRACTIONAL ±1/32" ANGULAR ±MACH 1" ONE PLACE DECIMAL ±0.1" TWO PLACE DECIMAL ±0.01" THREE PLACE DECIMAL ±0.002" MATERIAL:</small>		DRAWN BY	DATE	
<small>UNLESS OTHERWISE SPECIFIED</small>		ISSUED BY	DATE	CUSTOMER: RALSTON STOCK SHOP DRAWING NUMBER:
SEE BOM FINISH: SEE BOM		JOB ORDER NO.	CUSTOMER DRAWING NO.	
DO NOT SCALE DRAWING		(AUTHORIZED SIGNATURE IN RED) 		SIZE PART NAME: C N43P-SS-303008 REV. - PART NO. N43P-SS-303008 SCALE: 1:6 WEIGHT: 94.387 SHEET 1 OF 1