

4

3

2

1

REVISIONS			
REV.	DESCRIPTION	DATE	APPROVED

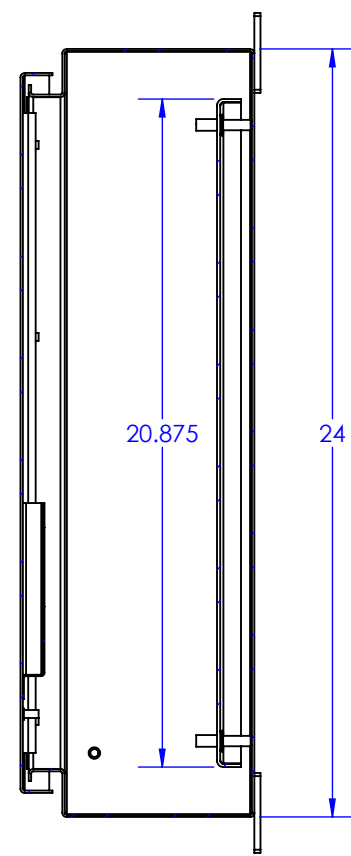
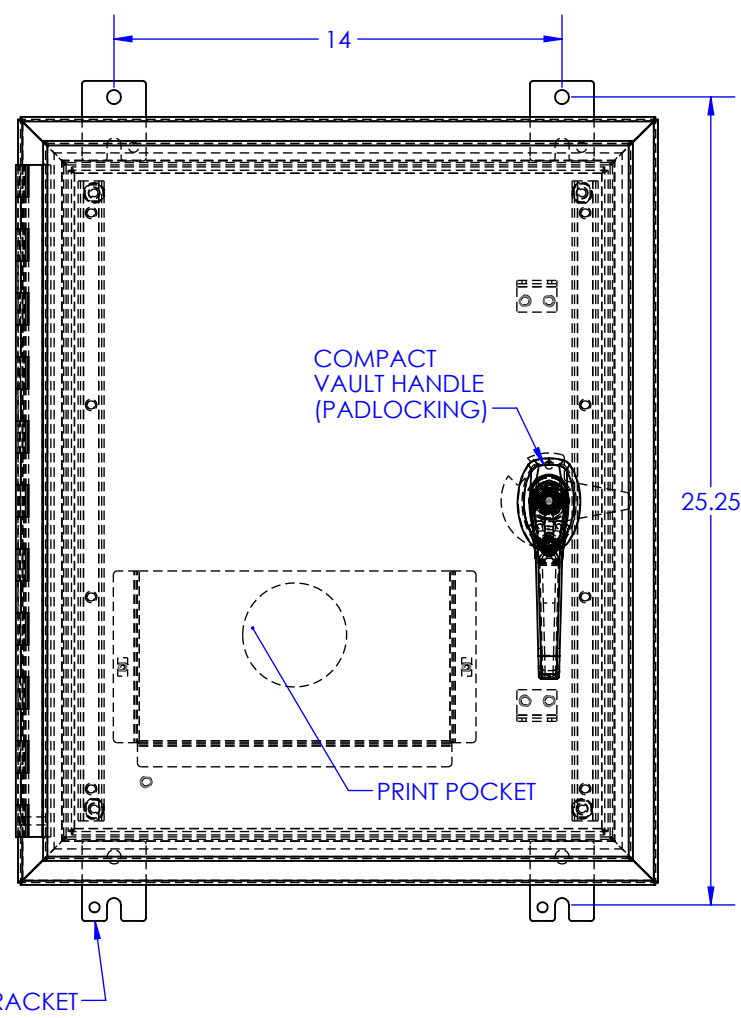
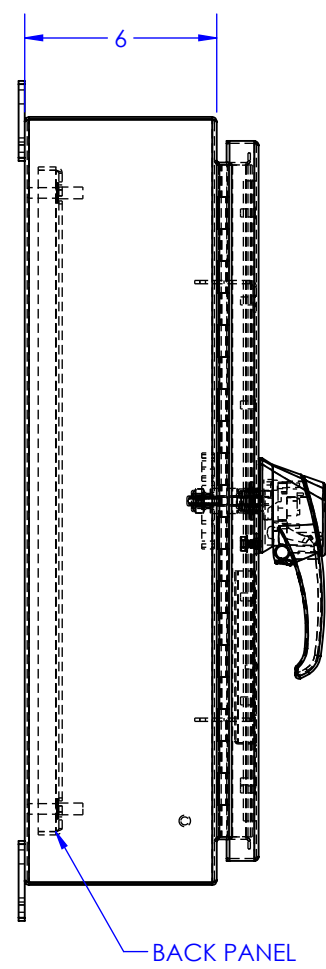
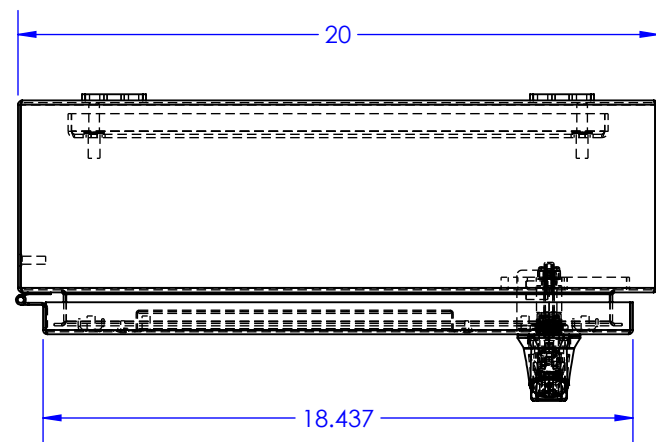

SECTION C-C

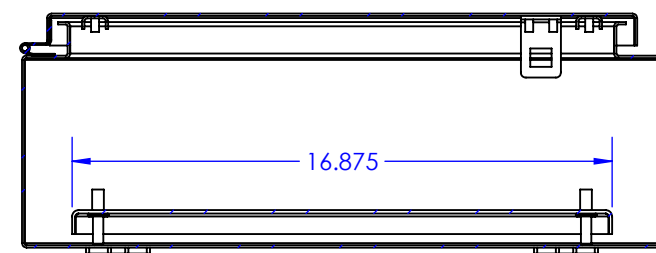

SECTION D-D

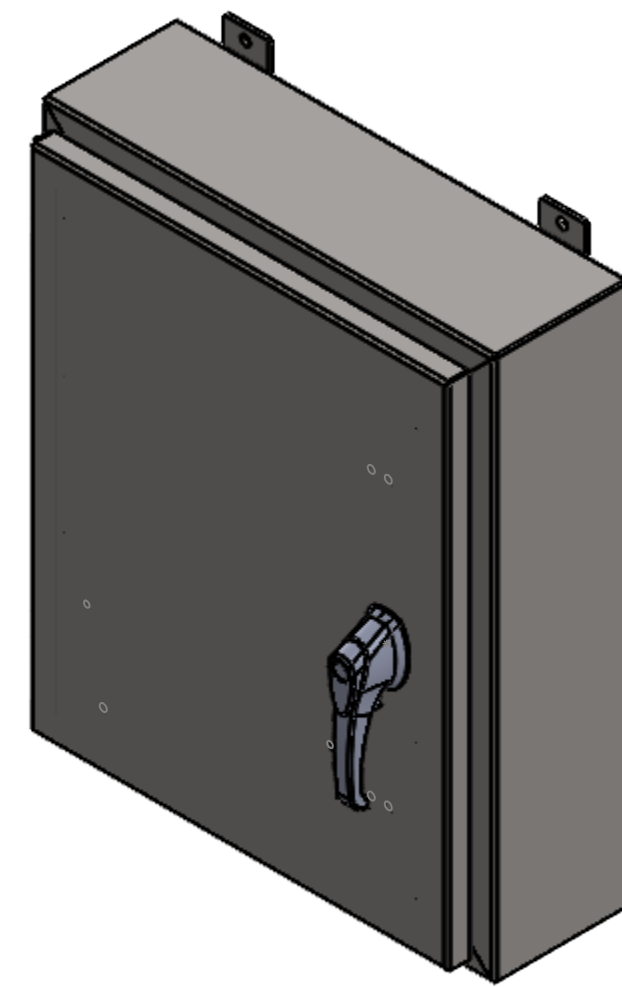

<b>PROPRIETARY AND CONFIDENTIAL</b>		NAME	DATE	<p>50 WATSON ROAD QUELPS, ONTARIO N1L 1E2 PHONE: (519) 836-2969 TOLL FREE: 1-800-265-7611 FAX: (519) 836-9793</p>	
THE INFORMATION CONTAINED IN THIS DRAWING IS THE SOLE PROPERTY OF RALSTON METAL PRODUCTS. ANY REPRODUCTION IN PART OR AS A WHOLE WITHOUT THE WRITTEN PERMISSION OF RALSTON METAL PRODUCTS IS PROHIBITED.		DRAWN BY	WAYNE SYMNOIT		2022-12-20
UNLESS OTHERWISE SPECIFIED		ISSUED BY	WAYNE SYMNOIT		2022-12-20
DIMENSIONS ARE IN INCHES		JOB ORDER NO.			
TOLERANCES:		CUSTOMER DRAWING NO.		RALSTON STOCK	
FRACTIONAL ± 1/32"				SHOP DRAWING NUMBER:	
ANGULAR MATCH 1"					
BEND ± 1/32"					
ONE PLACE DECIMAL ± 0.1"					
TWO PLACE DECIMAL ± 0.01"					
THREE PLACE DECIMAL ± 0.005"					
MATERIAL:					
SEE BOM		(AUTHORIZED SIGNATURE IN RED)		SIZE PART NAME: REV.	
FINISH:				<b>C</b> N43P-SS-242006 -	
SEE BOM		THIRD ANGLE PROJECTION		PART NO. N43P-SS-242006	
DO NOT SCALE DRAWING				SCALE: 1:6 WEIGHT: 52.917 SHEET 1 OF 1	

4

3

2

1