

2

1

B

B

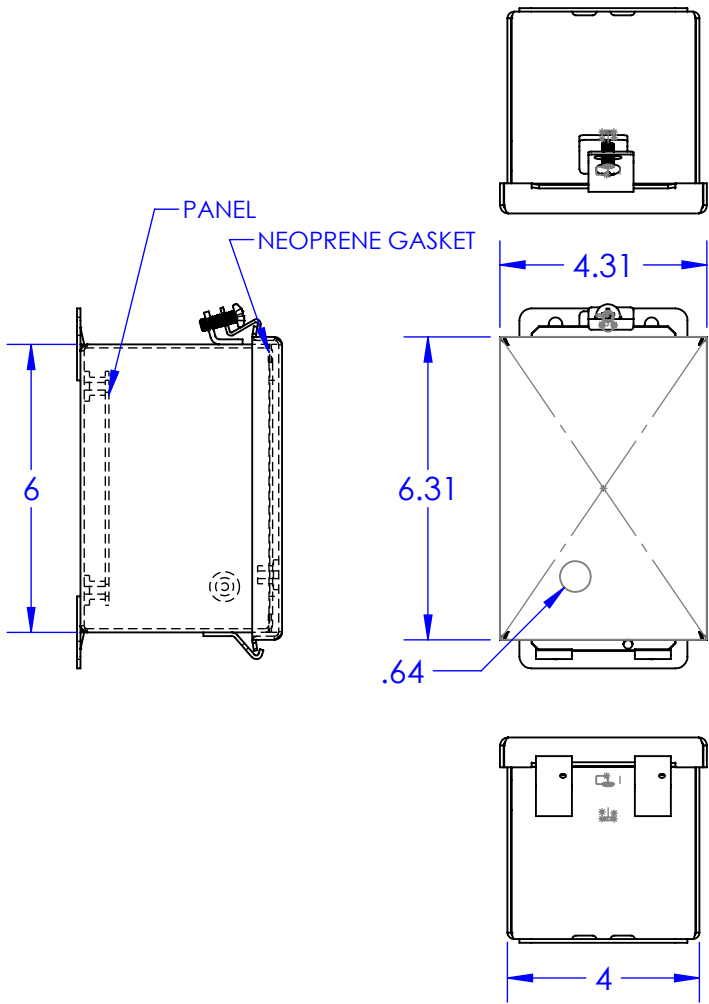

REVISIONS			
REV.	DESCRIPTION	DATE	APPROVED

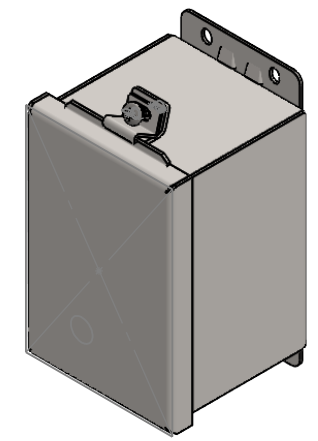
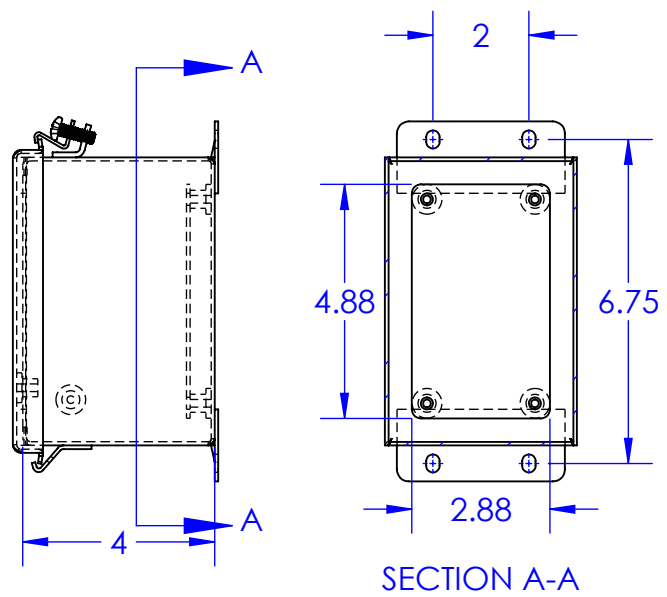

A

A

<p>PROPRIETARY AND CONFIDENTIAL</p> <p>THE INFORMATION CONTAINED IN THIS DRAWING IS THE SOLE PROPERTY OF RALSTON METAL PRODUCTS. ANY REPRODUCTION IN PART OR AS A WHOLE WITHOUT THE WRITTEN PERMISSION OF RALSTON METAL PRODUCTS IS PROHIBITED.</p> <p>UNLESS OTHERWISE SPECIFIED</p> <p>DIMENSIONS ARE IN INCHES</p> <p>TOLERANCES:</p> <p>FRACTIONAL $\pm 1/32"$</p> <p>ANGULAR: MACH $\pm 1^\circ$ BEND $\pm 1/32"$</p> <p>ONE PLACE DECIMAL $\pm 0.1"$</p> <p>TWO PLACE DECIMAL $\pm 0.01"$</p> <p>THREE PLACE DECIMAL $\pm 0.005"$</p> <p>MATERIAL:</p> <p>SEE BOM</p> <p>FINISH:</p> <p>SEE BOM</p> <p>DO NOT SCALE DRAWING</p>	<p>NAME</p> <p>DATE</p>	<p>50 Watson Road Guelph, Ontario N1L 1E2</p> <p>Phone: (519) 836-2968 Toll Free: 1-800-265-7611 Fax: (519) 836-9763 www.ralstonmetal.com</p>
	<p>DRAWN BY: DAVE BURNS</p> <p>2019-02-06</p> <p>ISSUED BY:</p> <p>JOB ORDER NO:</p> <p>CUSTOMER DRAWING NO:</p> <p>(AUTHORIZED SIGNATURE IN RED)</p> <p>THIRD ANGLE PROJECTION</p>	

2

1