

4

3

2

1

REVISIONS			
REV.	DESCRIPTION	DATE	APPROVED

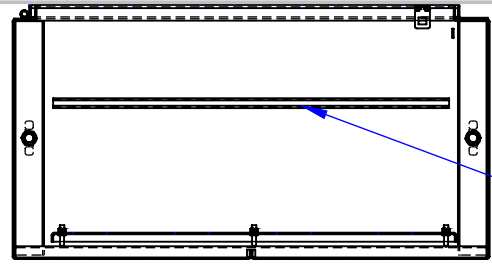

LIGHT BRACKET

SECTION F-F

SECTION B-B

SECTION A-A

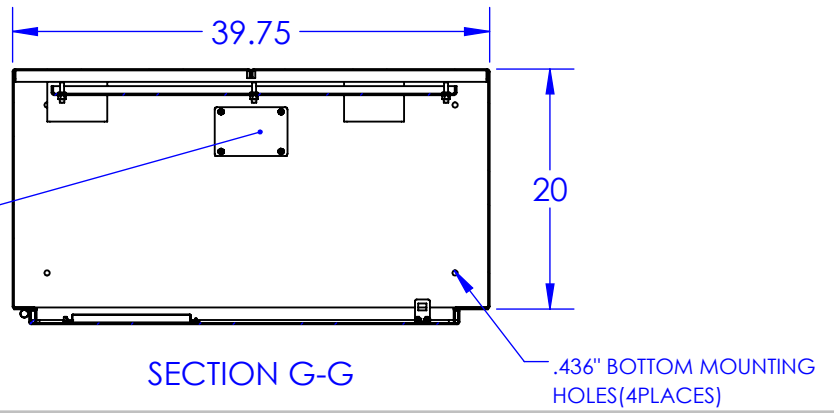
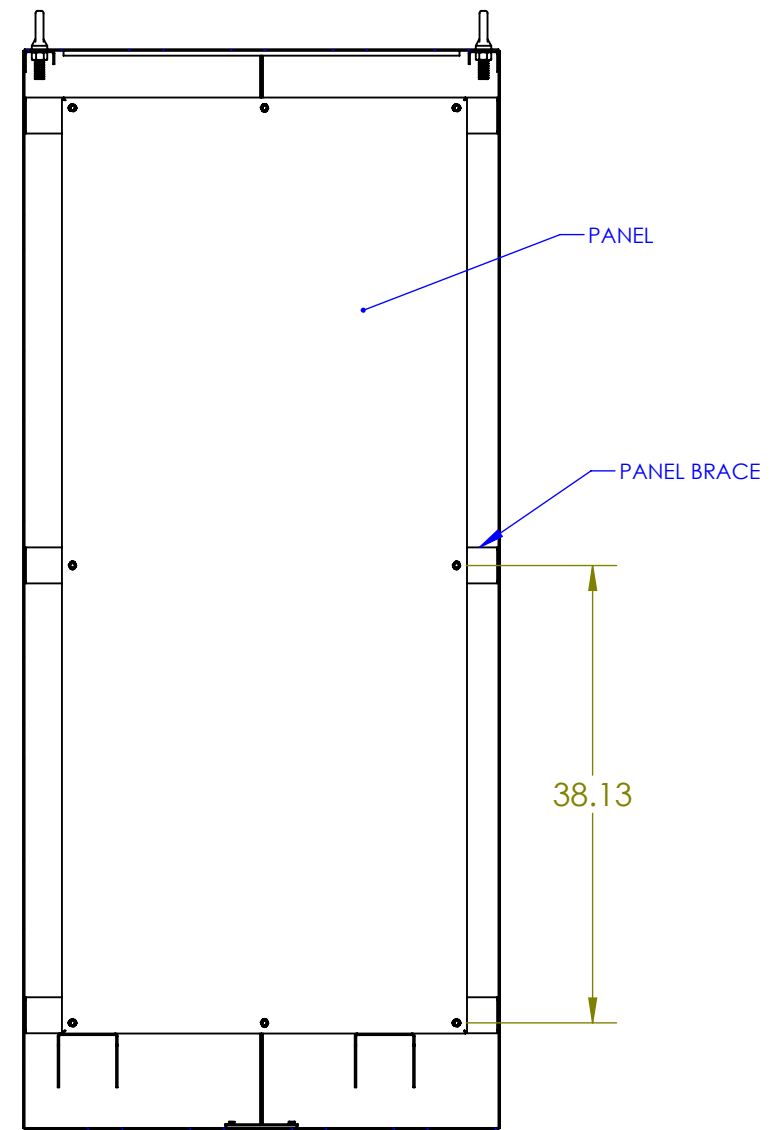
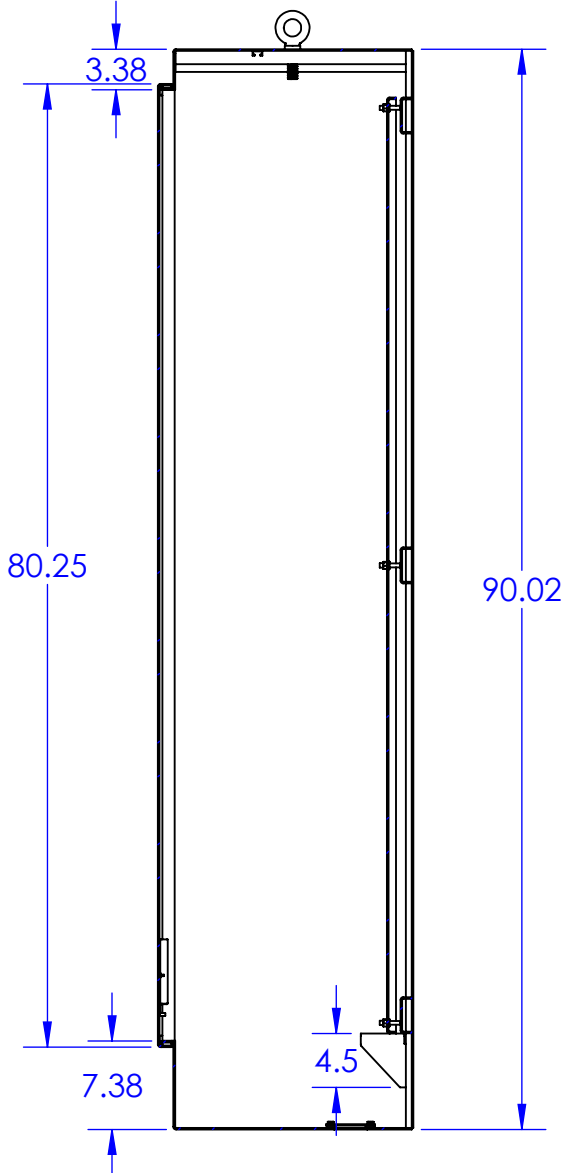
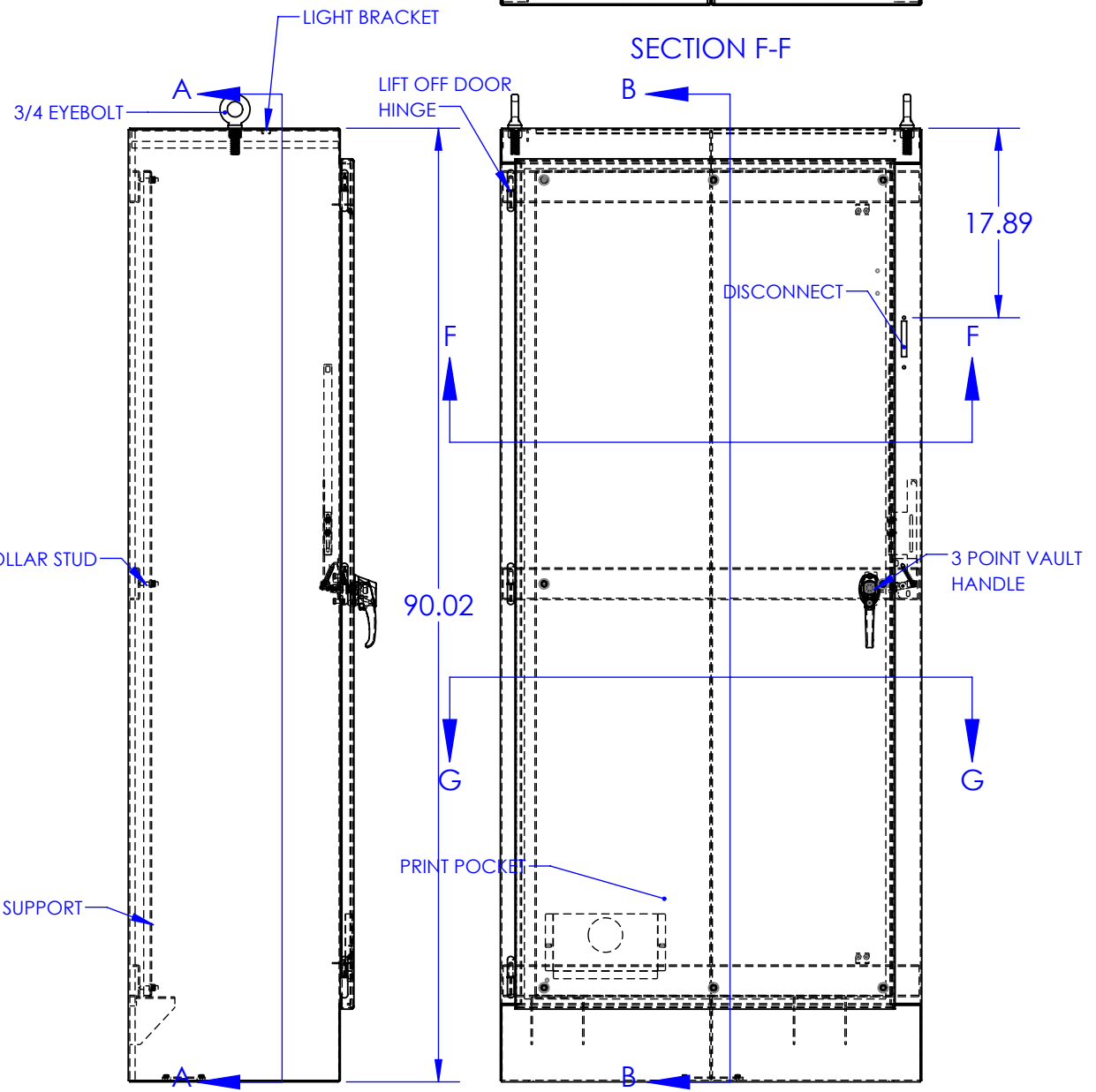

DRAIN & DRAIN COVER IN BOTTOM OF ENCLOSURE

.436" BOTTOM MOUNTING HOLES (4 PLACES)

PROPRIETARY AND CONFIDENTIAL THE INFORMATION CONTAINED IN THIS DRAWING IS THE SOLE PROPERTY OF RALSTON METAL PRODUCTS. ANY REPRODUCTION IN PART OR AS A WHOLE WITHOUT THE WRITTEN PERMISSION OF RALSTON METAL PRODUCTS IS PROHIBITED. UNLESS OTHERWISE SPECIFIED DIMENSIONS ARE IN INCHES TOLERANCES: FRACTIONAL: ±1/32" ANGULAR: MACH ±1° BEND ±1/32" ONE PLACE DECIMAL ±0.1" TWO PLACE DECIMAL ±0.01" THREE PLACE DECIMAL ±0.005" MATERIAL: SEE BOM FINISH: SEE BOM DO NOT SCALE DRAWING	NAME: DAVID CIKURU DATE: 3/27/2019 ISSUED BY: JOB ORDER NO.: CUSTOMER DRAWING NO.: (AUTHORIZED SIGNATURE IN RED) THIRD ANGLE PROJECTION	50 Watson Road Guelph, Ontario N1L 1E2 Phone: (519) 836-2968 Toll Free: 1-800-265-7611 Fax: (519) 836-9763 www.ralstonmetal.com Ralston Metal Products Limited CUSTOMER: SHOP DRAWING NUMBER: SIZE: B PART NAME: 4-1D-904020 REV.: PART NO. 4-1D-904020 SCALE: 1:16 WEIGHT: 600.255 SHEET 1 OF 1
--	---	--

B

B

A

A

4

3

2

1