

4

3

2

1

REVISIONS			
REV.	DESCRIPTION	DATE	APPROVED

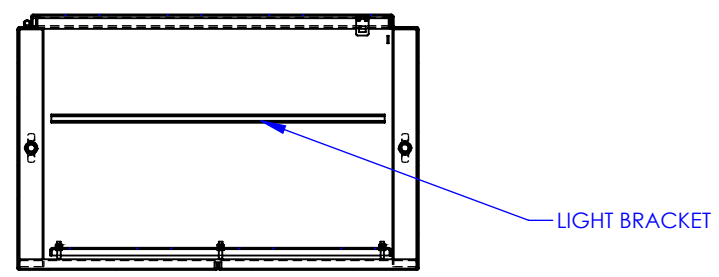

SECTION F-F

LIGHT BRACKET

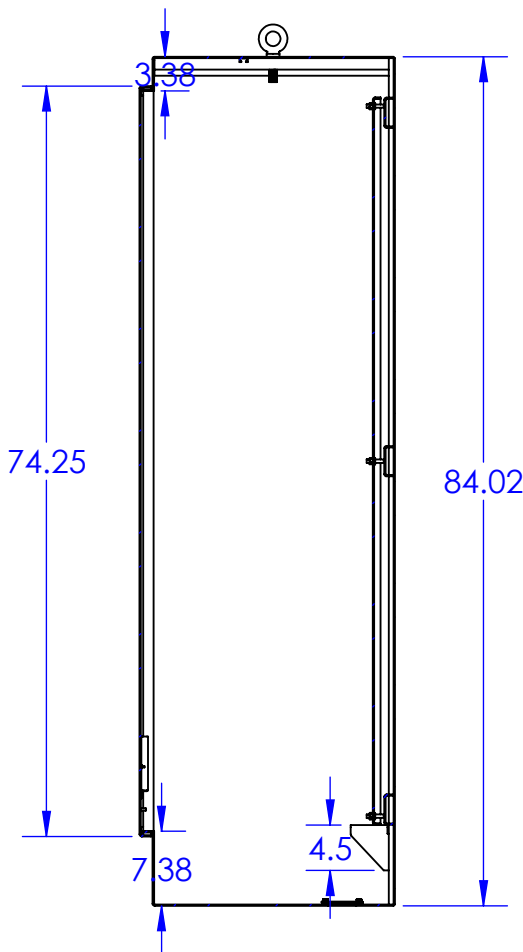
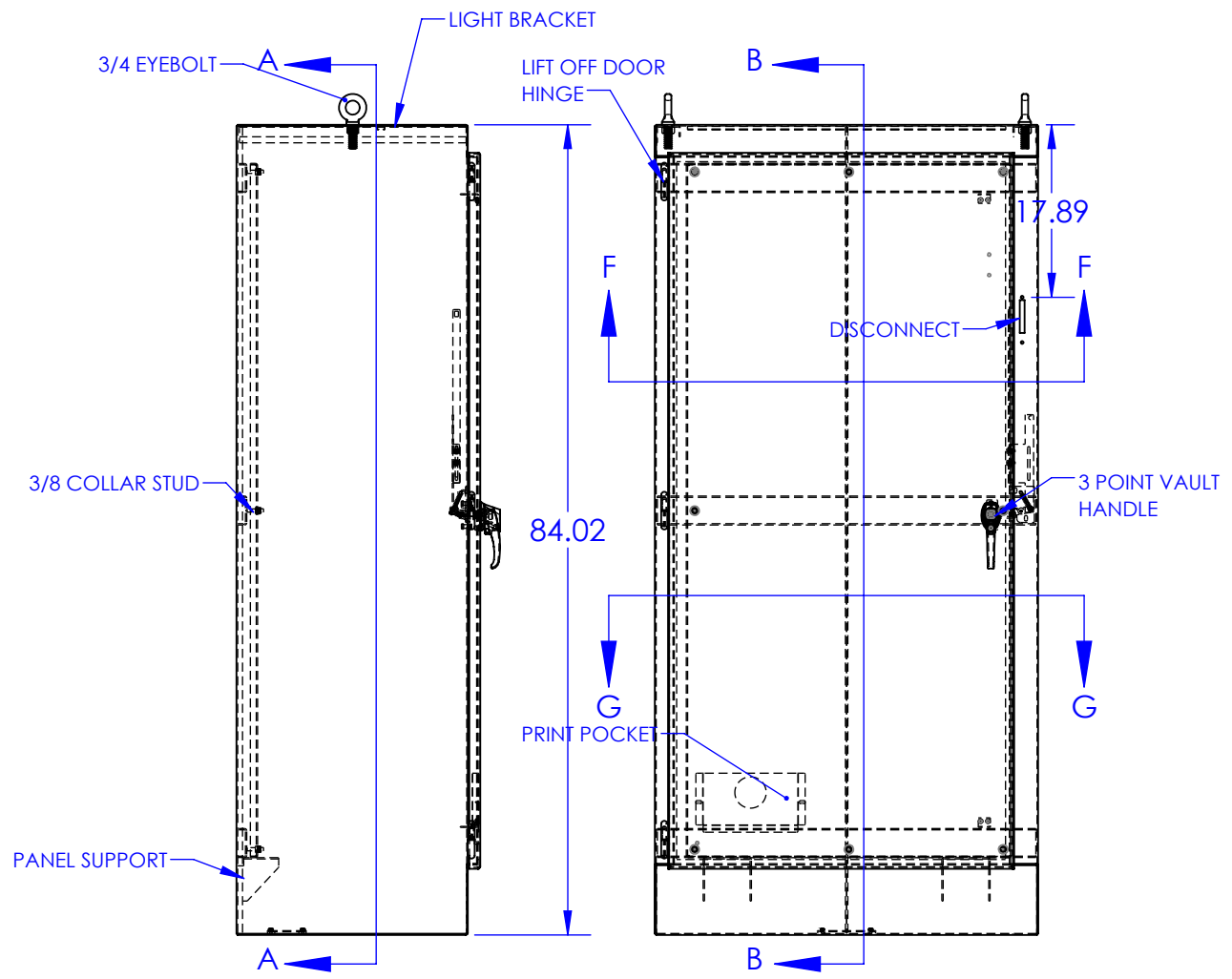

SECTION B-B

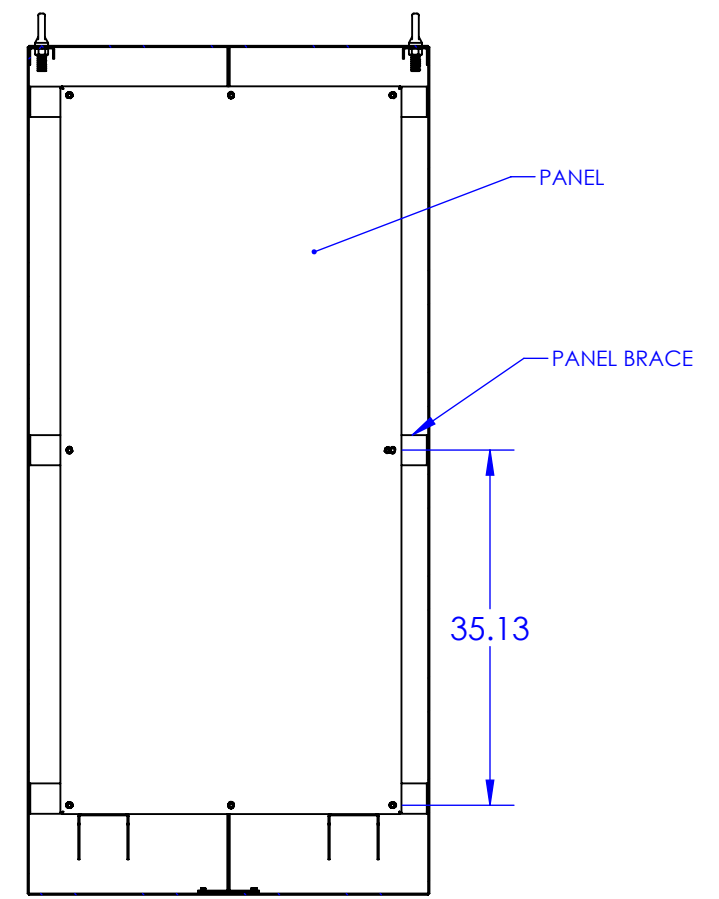

SECTION A-A

B

B

A

A

DRAIN & DRAIN COVER IN BOTTOM OF ENCLOSER

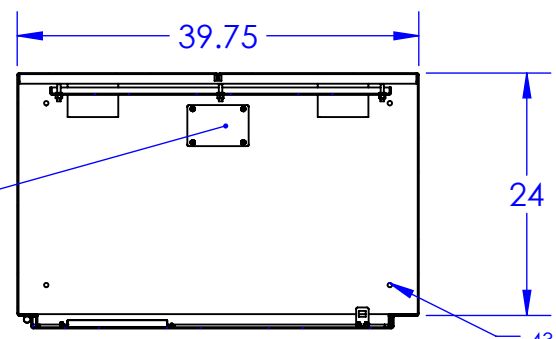

SECTION G-G

.436" BOTTOM MOUNTING HOLES(4PLACES)

<b>PROPRIETARY AND CONFIDENTIAL</b> THE INFORMATION CONTAINED IN THIS DRAWING IS THE SOLE PROPERTY OF RALSTON METAL PRODUCTS. ANY REPRODUCTION IN PART OR AS A WHOLE WITHOUT THE WRITTEN PERMISSION OF RALSTON METAL PRODUCTS IS PROHIBITED.  <b>UNLESS OTHERWISE SPECIFIED</b> DIMENSIONS ARE IN INCHES TOLERANCES: FRACTIONAL: ±1/32" ANGULAR: MACH ±1° BEND ±1/32" ONE PLACE DECIMAL ±0.1" TWO PLACE DECIMAL ±0.01" THREE PLACE DECIMAL ±0.005" MATERIAL:  SEE BOM FINISH: SEE BOM DO NOT SCALE DRAWING	NAME DAVID CIKURU DATE 3/27/2019	50 Watson Road Guelph, Ontario N1L 1E2 Phone: (519) 836-2968 Toll Free: 1-800-265-7611 Fax: (519) 836-9763 <a href="http://www.ralstonmetal.com">www.ralstonmetal.com</a>
	ISSUED BY JOB ORDER NO:  CUSTOMER DRAWING NO:  (AUTHORIZED SIGNATURE IN RED) 	CUSTOMER:  SHOP DRAWING NUMBER:  SIZE <b>B</b>
PART NO. 4-1D-844024 SCALE: 1:19 WEIGHT: 602.933 SHEET 1 OF 1	PART NAME: <b>4-1D-844024</b>	REV.

4

3

2

1