

4

3

2

1

REVISIONS			
REV.	DESCRIPTION	DATE	APPROVED

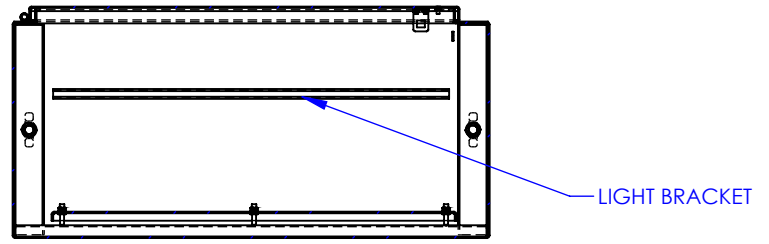

SECTION F-F

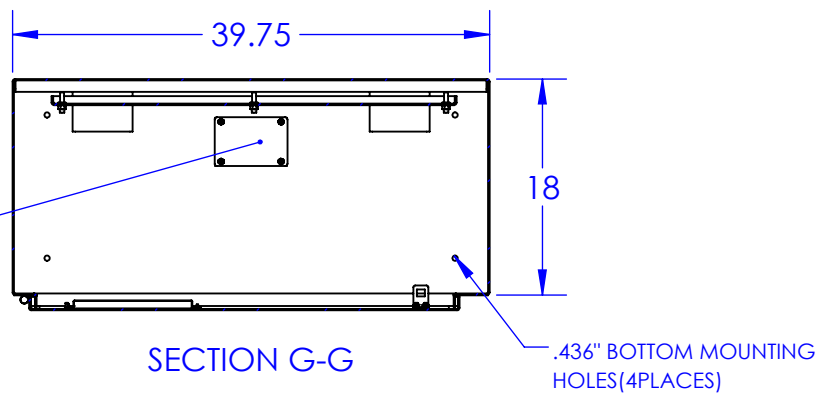
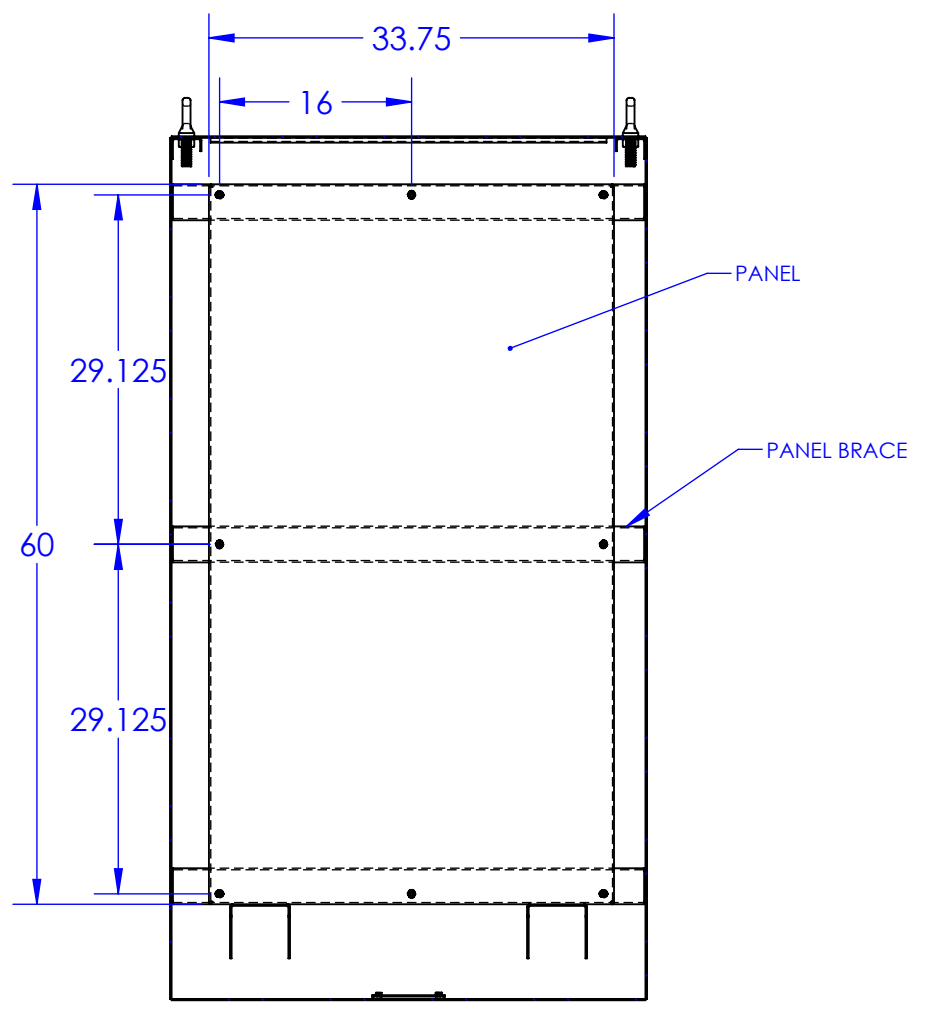
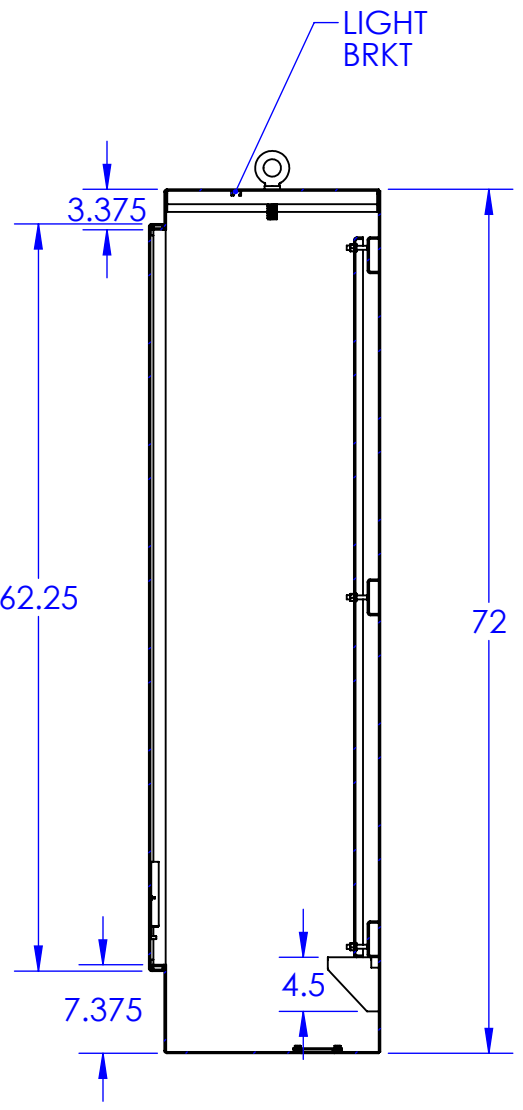
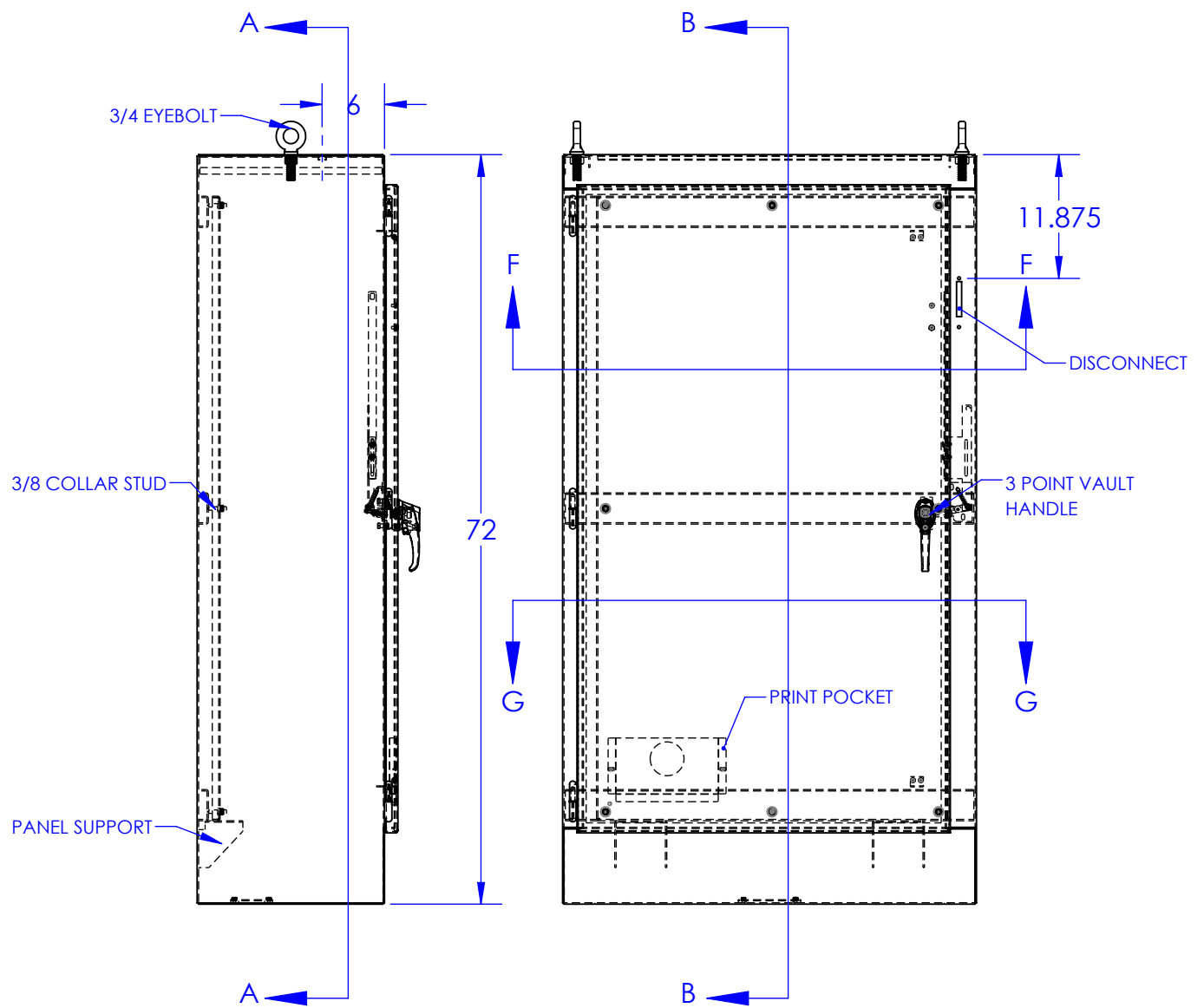

PROPRIETARY AND CONFIDENTIAL

THE INFORMATION CONTAINED IN THIS DRAWING IS THE SOLE PROPERTY OF RALSTON METAL PRODUCTS. ANY REPRODUCTION IN PART OR AS A WHOLE WITHOUT THE WRITTEN PERMISSION OF RALSTON METAL PRODUCTS IS PROHIBITED.

UNLESS OTHERWISE SPECIFIED

DIMENSIONS ARE IN INCHES

TOLERANCES:

FRACTIONAL: ±1/32"

ANGULAR: MACH ±1° BEND ±1/32"

ONE PLACE DECIMAL ±0.1"

TWO PLACE DECIMAL ±0.01"

THREE PLACE DECIMAL ±0.005"

MATERIAL:

SEE BOM

FINISH:

SEE BOM

DO NOT SCALE DRAWING

NAME	DATE
DRAWN BY: DAVE BURNS	2023-03-06
ISSUED BY: DAVE BURNS	2023-03-06
JOB ORDER NO:	
CUSTOMER DRAWING NO:	

(AUTHORIZED SIGNATURE IN RED)

THIRD ANGLE PROJECTION

50 Watson Road
Guelph, Ontario N1L 1E2
Phone: (519) 836-2968
Toll Free: 1-800-265-7611
Fax: (519) 836-9763
www.ralstonmetal.com

Ralston
Metal Products Limited

CUSTOMER: RALSTON STOCK

SHOP DRAWING NUMBER:

SIZE	PART NAME:	REV.
B	4000-1D-724018	

PART NO. 4000-1D-724018

SCALE: 1:16 WEIGHT: 473.145 SHEET 1 OF 1

4

3

2

1