

4

3

2

1

REVISIONS			
REV.	DESCRIPTION	DATE	APPROVED

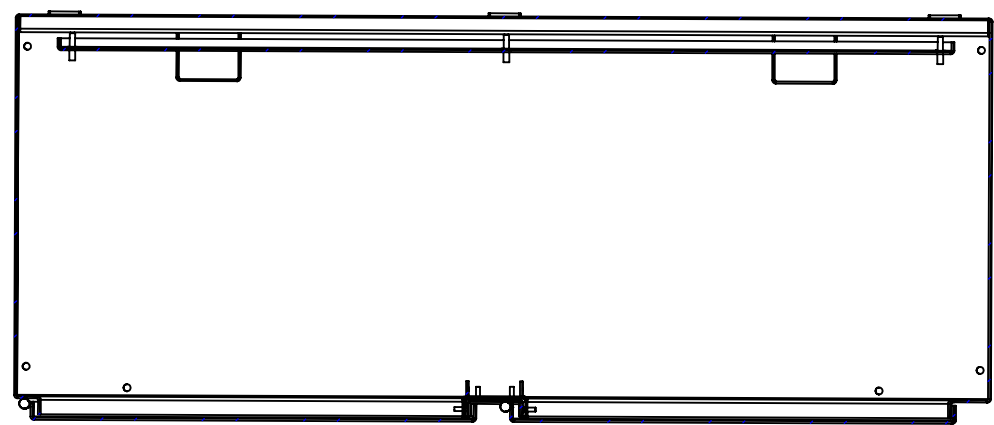
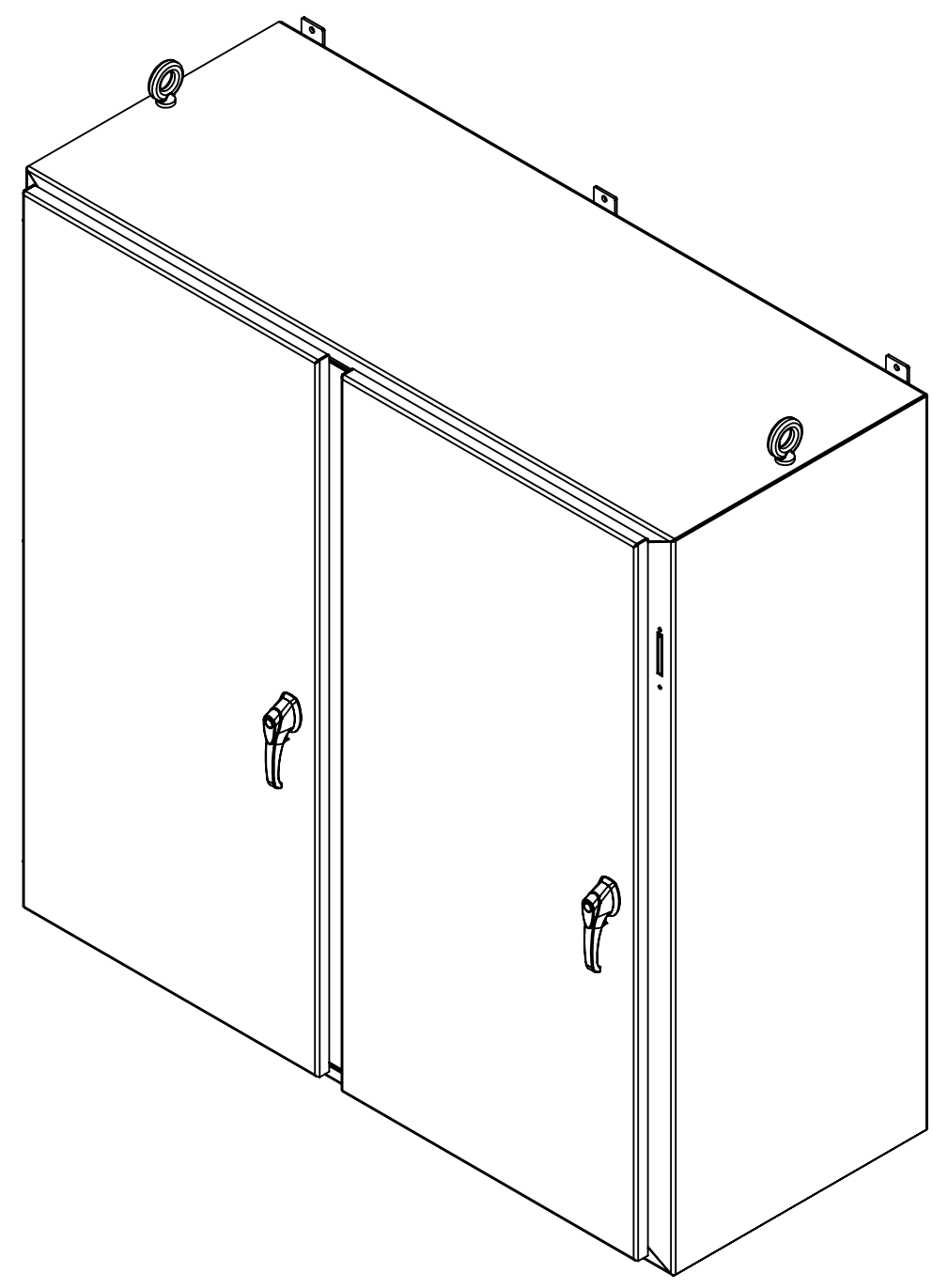
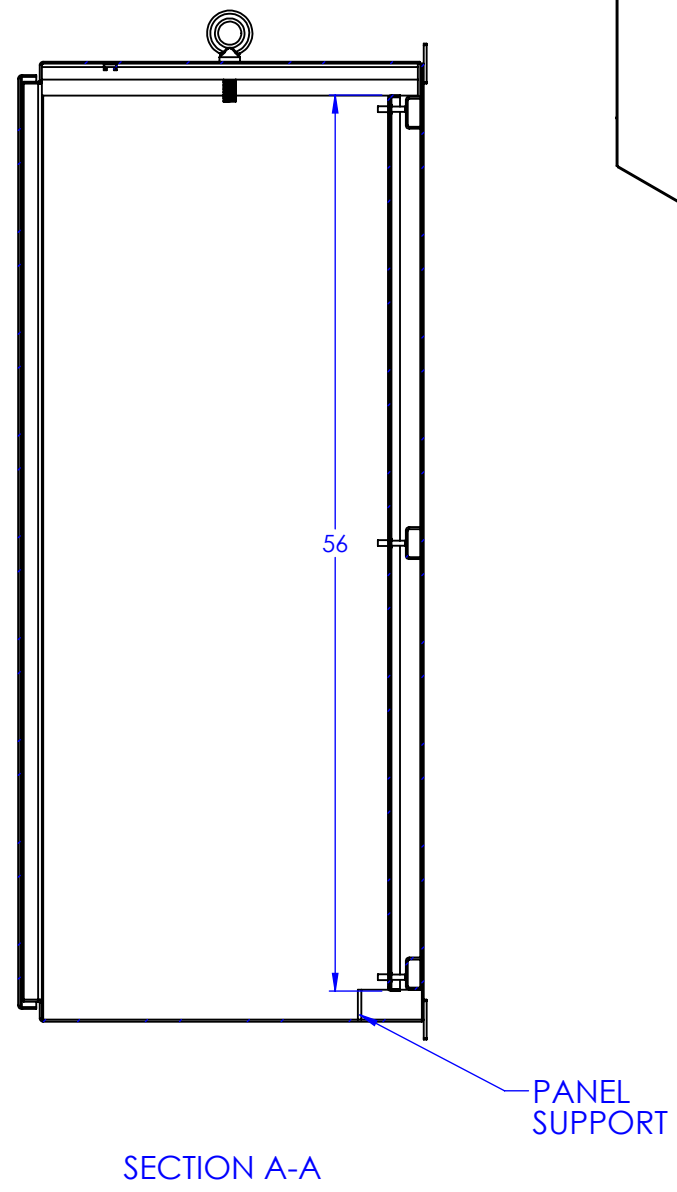
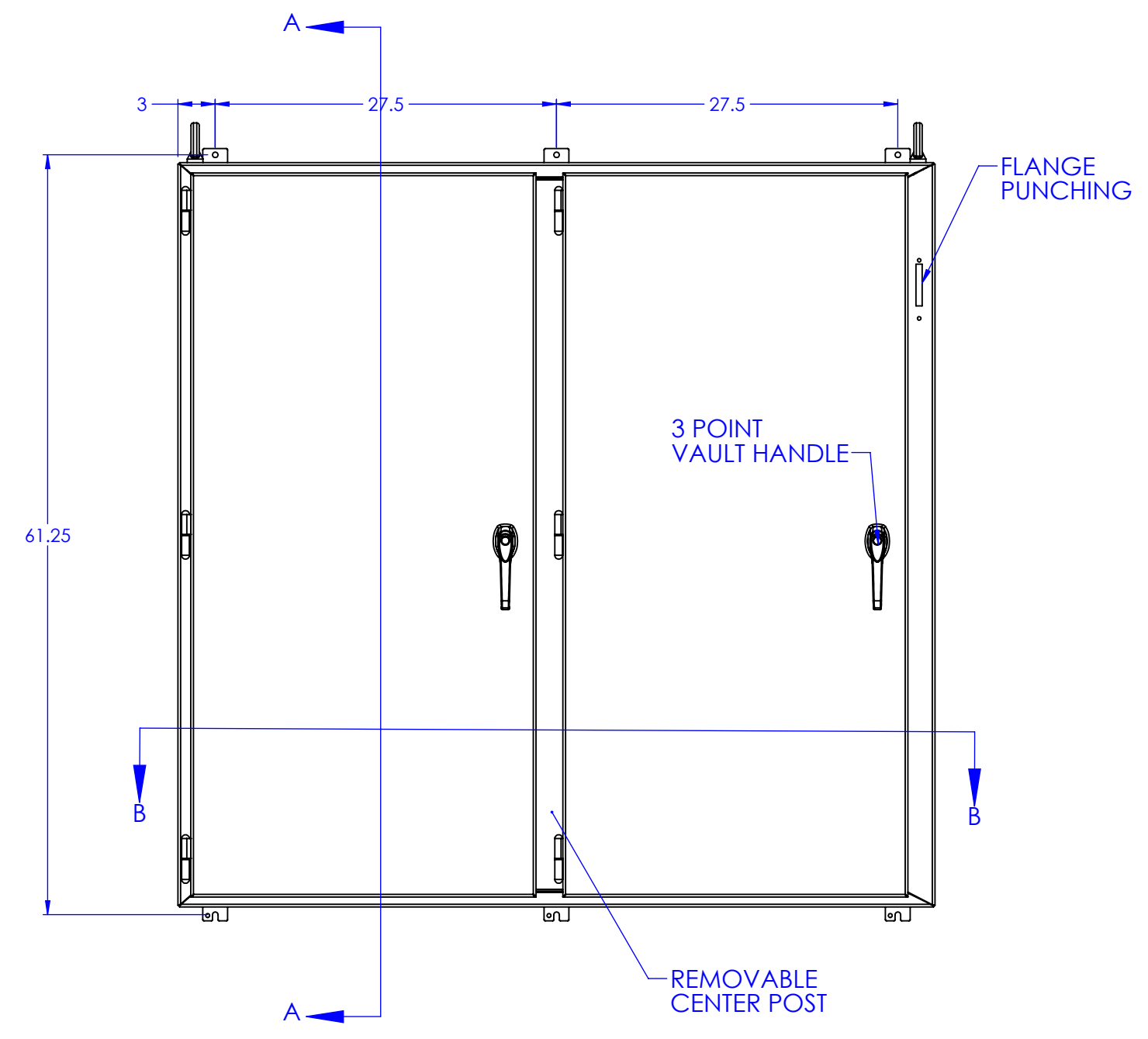
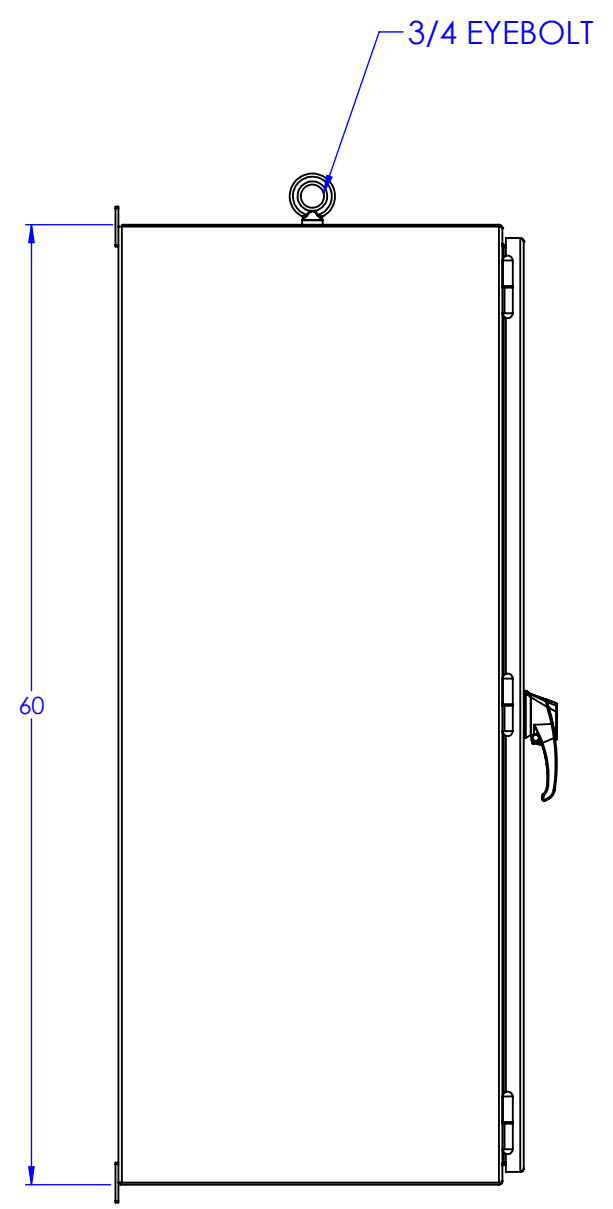
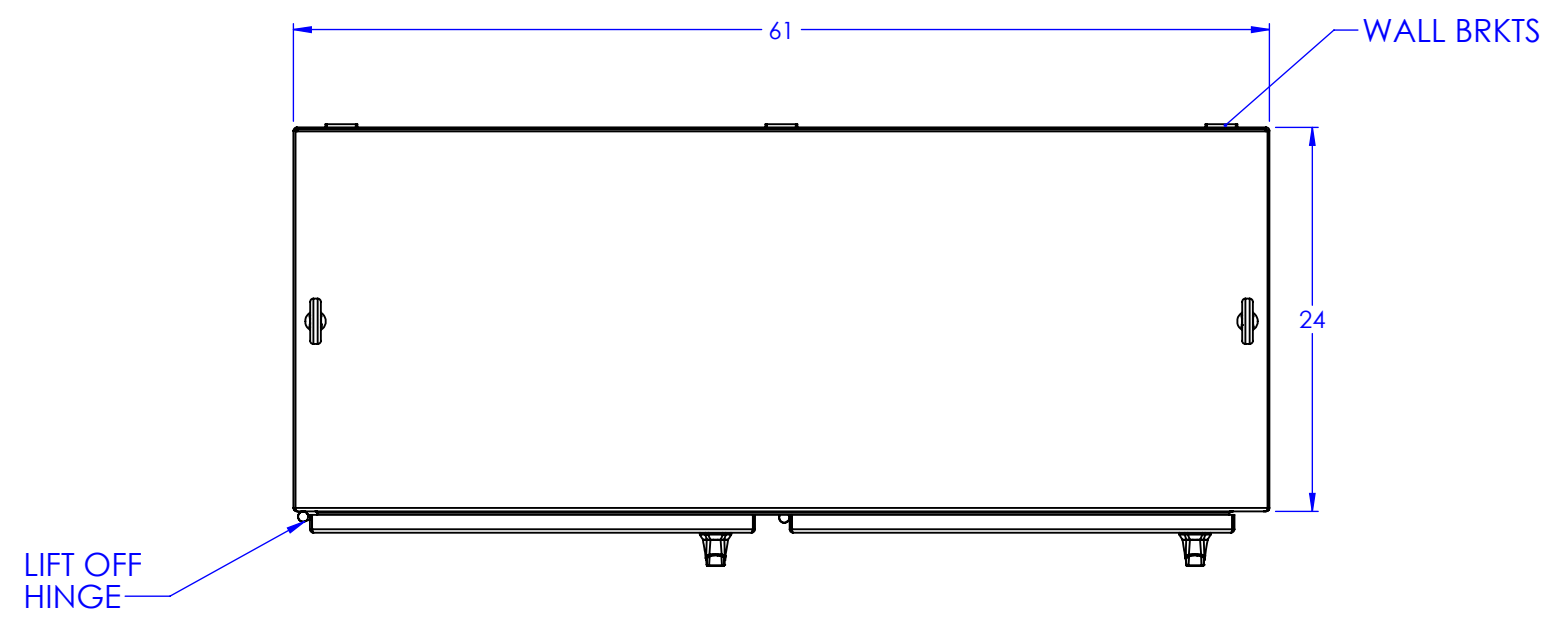

SECTION B-B

PROPRIETARY AND CONFIDENTIAL THE INFORMATION CONTAINED IN THIS DRAWING IS THE SOLE PROPERTY OF RALSTON METAL PRODUCTS. ANY REPRODUCTION IN PART OR AS A WHOLE WITHOUT THE WRITTEN PERMISSION OF RALSTON METAL PRODUCTS IS PROHIBITED. UNLESS OTHERWISE SPECIFIED DIMENSIONS ARE IN INCHES TOLERANCES: FRACTIONAL ±1/32" ANGULAR MACH±1° ONE PLACE DECIMAL ±0.1" TWO PLACE DECIMAL ±0.01" THREE PLACE DECIMAL ±0.005" MATERIAL: SEE BOM FINISH: SEE BOM DO NOT SCALE DRAWING	NAME DAVE BURNS DATE 2023-02-09 ISSUED BY DAVE BURNS 2023-02-09 JOB ORDER NO:	58 WATSON ROAD QUELUP, ONTARIO N7L 1E2 PHONE: (519) 836-2968 TOLL FREE: 1-800-265-7611 FAX: (519) 836-9793 Ralston Metal Products Limited www.RALSTONMETAL.COM	CUSTOMER: RALSTON STOCK SHOP DRAWING NUMBER:	
	CUSTOMER DRAWING NO: (AUTHORIZED SIGNATURE IN RED) 	SIZE C	PART NAME: 2000-FM-606124	REV. -
	PART NO. 2000-FM-606124	SCALE: 1:12	WEIGHT: 651.884	SHEET 1 OF 1

4

3

2

1