

REVISIONS			
REV.	DESCRIPTION	DATE	APPROVED

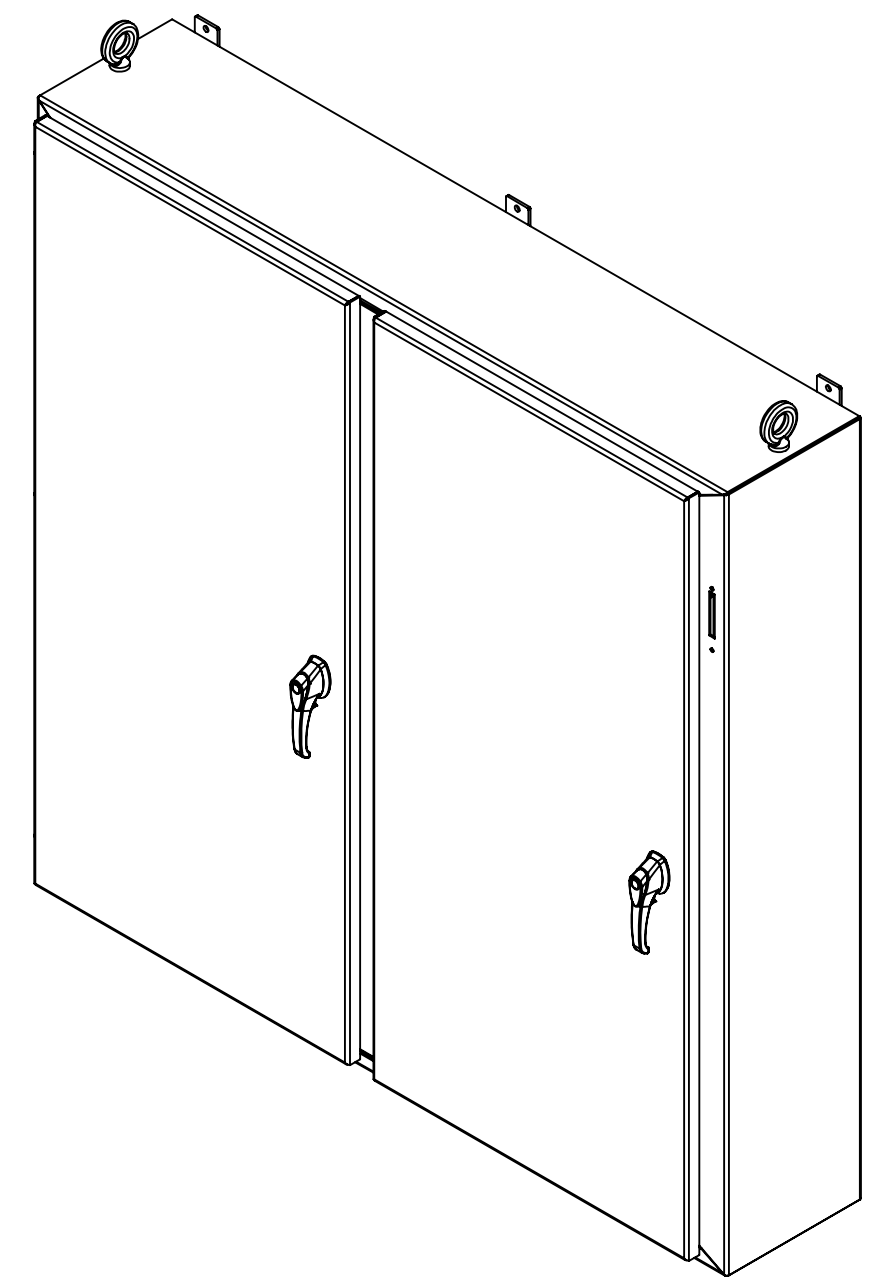
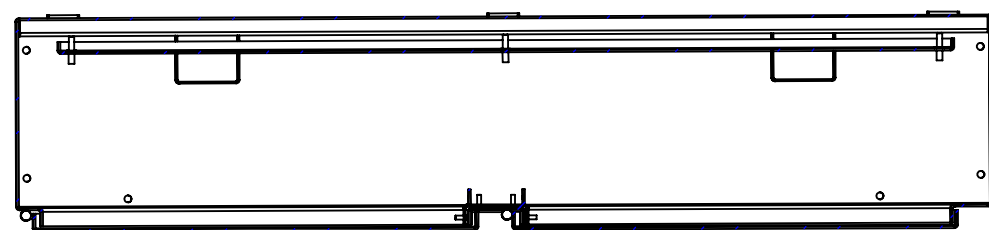
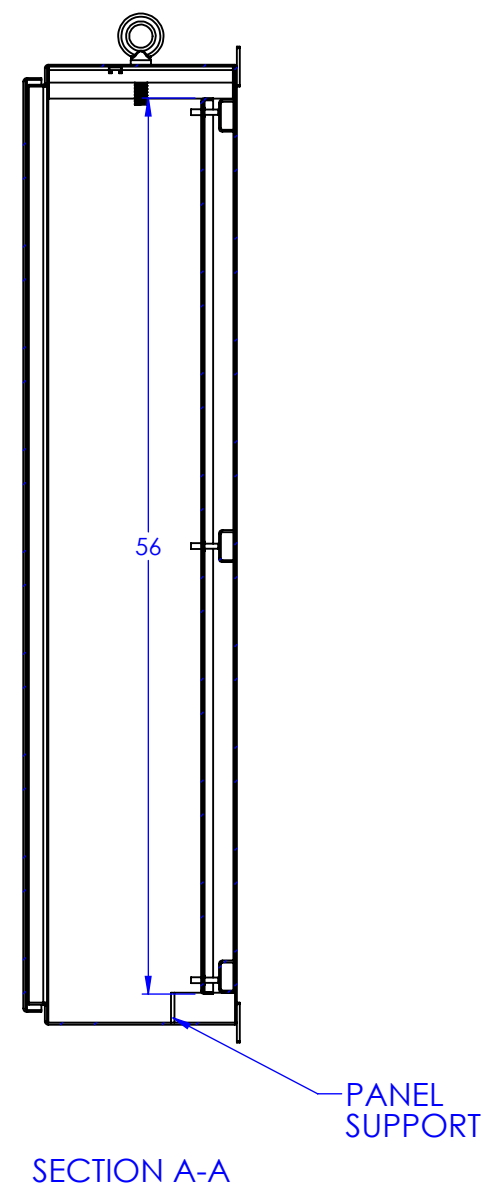
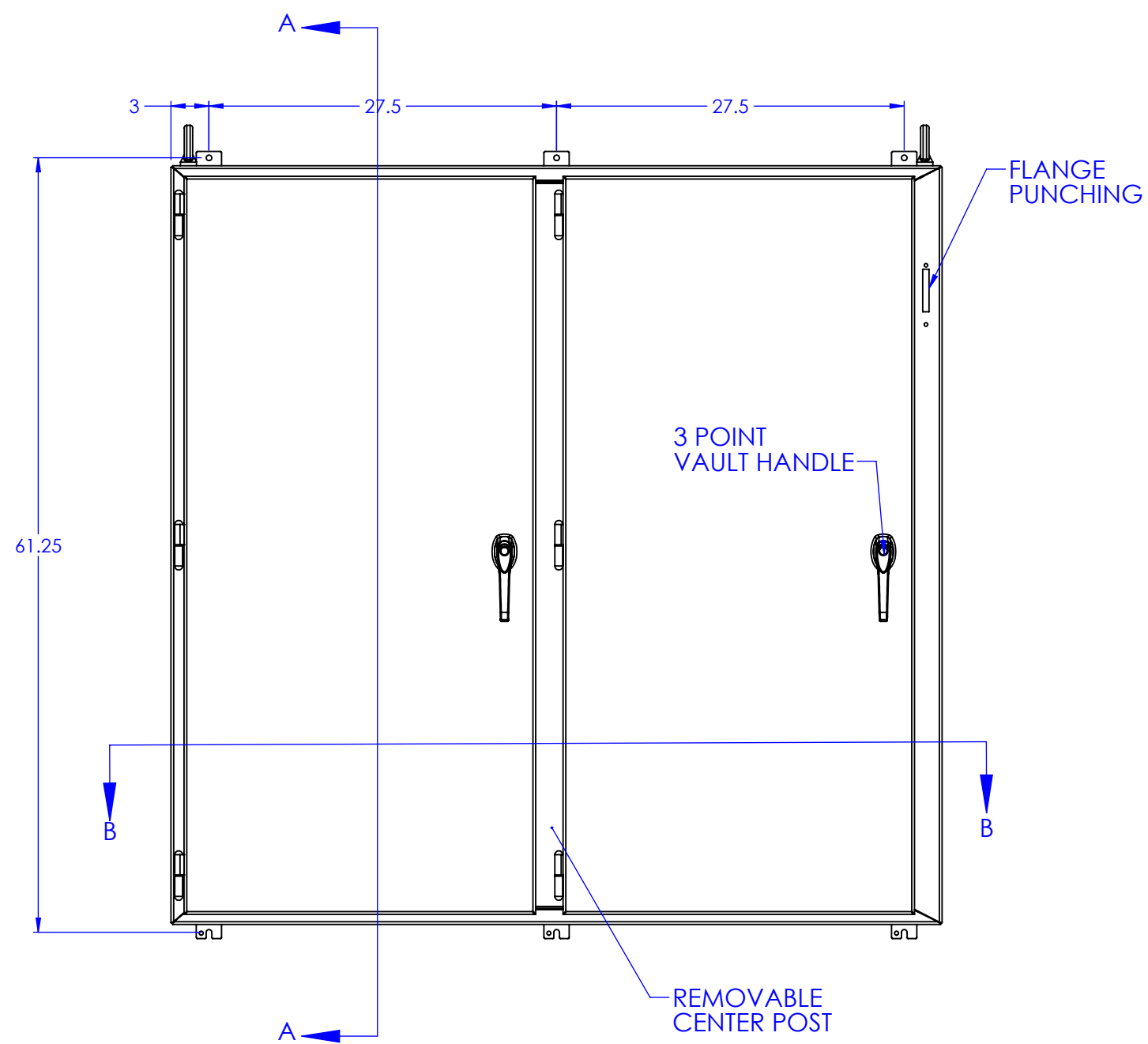
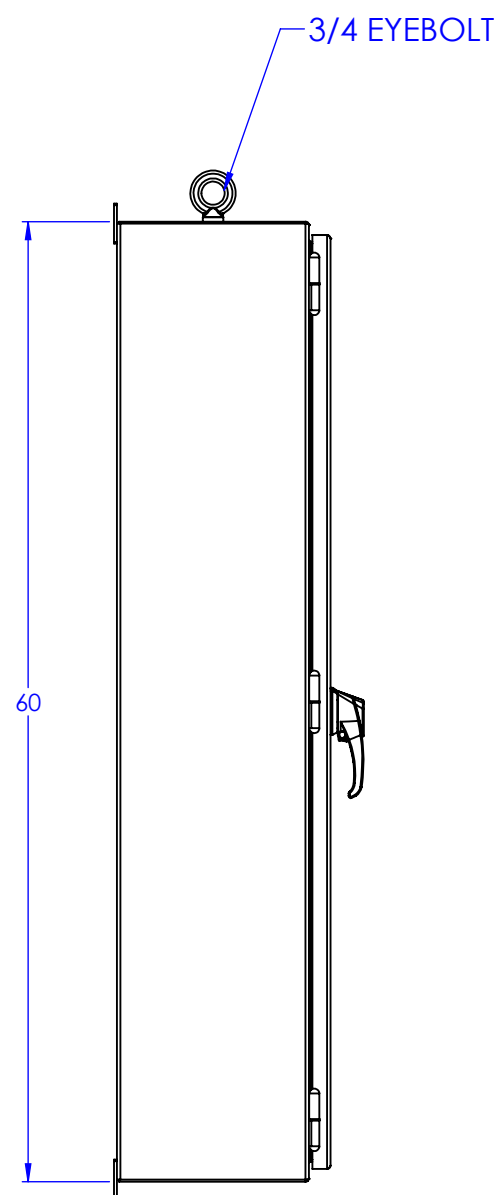
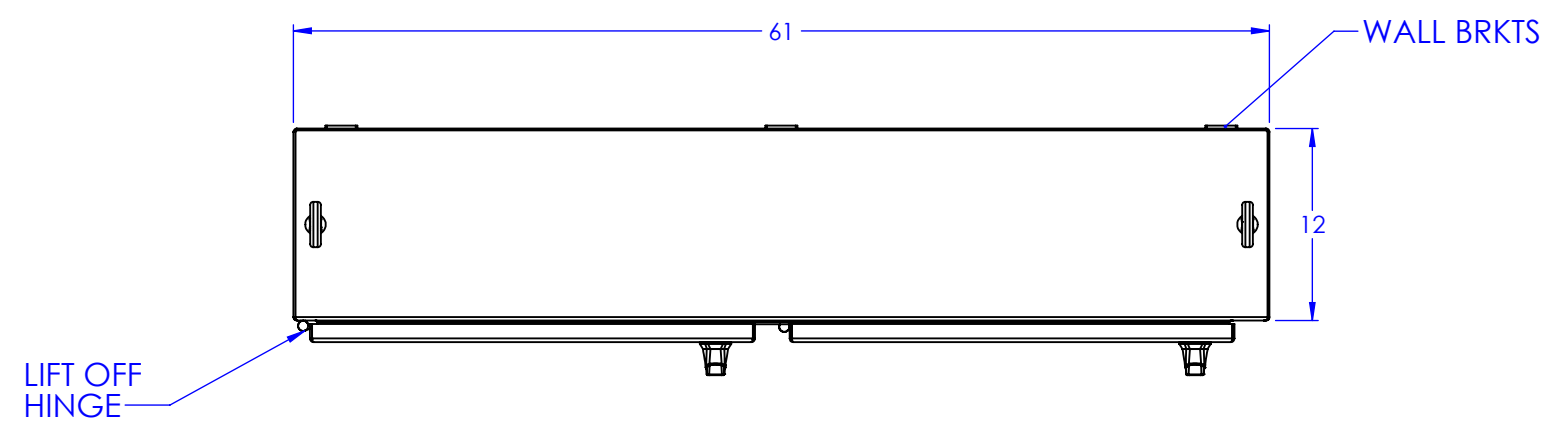

PROPRIETARY AND CONFIDENTIAL THE INFORMATION CONTAINED IN THIS DRAWING IS THE SOLE PROPERTY OF RALSTON METAL PRODUCTS. ANY REPRODUCTION IN PART OR AS A WHOLE WITHOUT THE WRITTEN PERMISSION OF RALSTON METAL PRODUCTS IS PROHIBITED.	NAME	DATE		58 WATSON ROAD QUELPHI, ONTARIO N7L 1E2 PHONE: (519) 836-2968 TOLL FREE: 1-800-265-7611 FAX: (519) 836-9793
	DRAWN BY	ISSUED BY		CUSTOMER:
	ISSUED BY	DATE		RALSTON STOCK
	JOB ORDER NO:			SHOP DRAWING NUMBER:
DIMENSIONS ARE IN INCHES TOLERANCES: FRACTIONAL ±1/32" ANGULAR ±MACH 1" ONE PLACE DECIMAL ±0.1" TWO PLACE DECIMAL ±0.01" THREE PLACE DECIMAL ±0.005" MATERIAL:	CUSTOMER DRAWING NO: (AUTHORIZED SIGNATURE IN RED)	SIZE PART NAME: C 2000-FM-606112	REV.	-
FINISH: SEE BOM	THIRD ANGLE PROJECTION	PART NO. 2000-FM-606112 SCALE: 1:12 WEIGHT: 545.958	SHEET 1 OF 1	