

REVISIONS			
REV.	DESCRIPTION	DATE	APPROVED

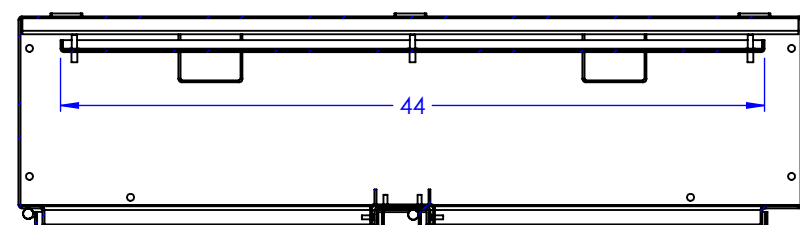
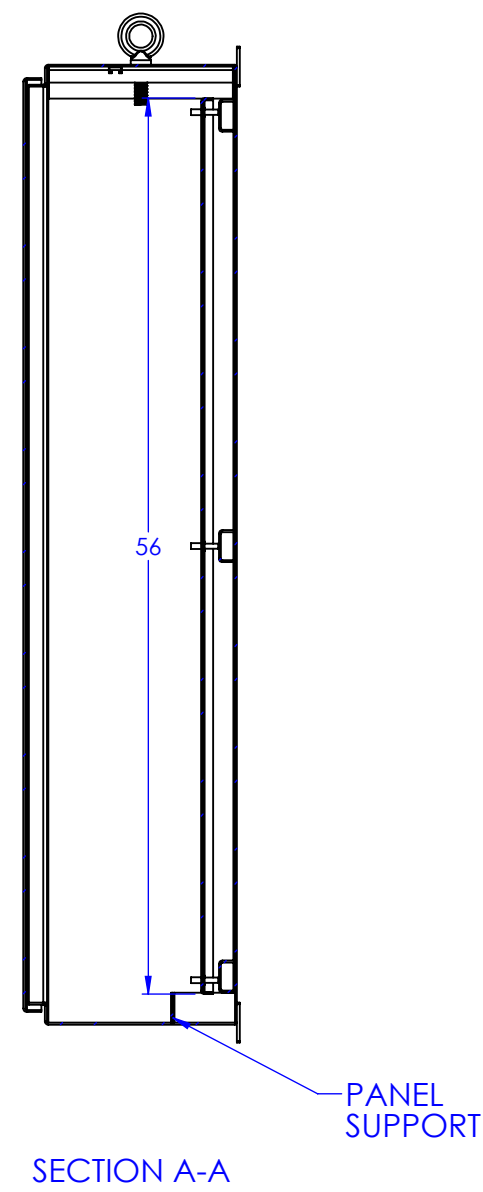
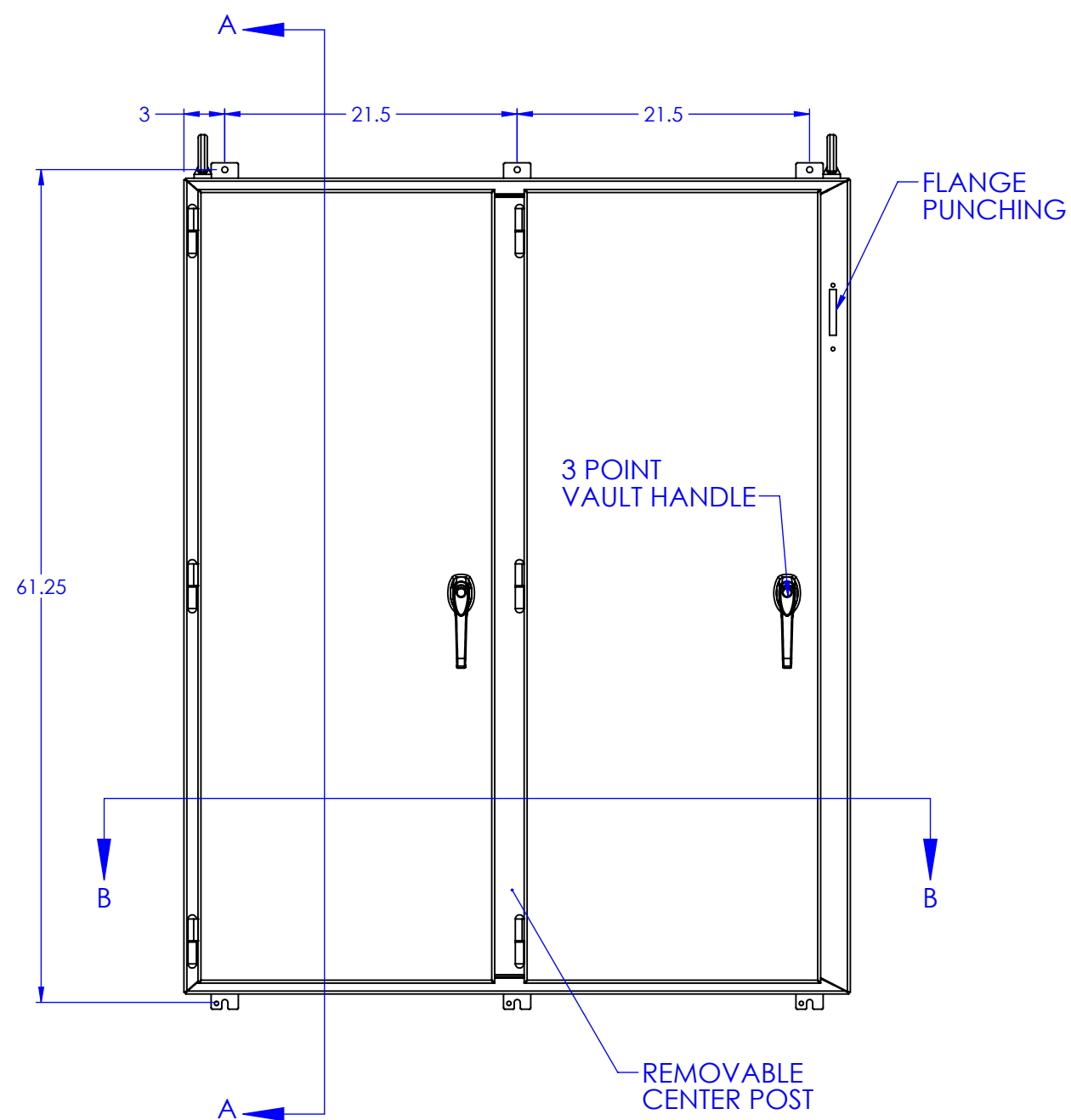
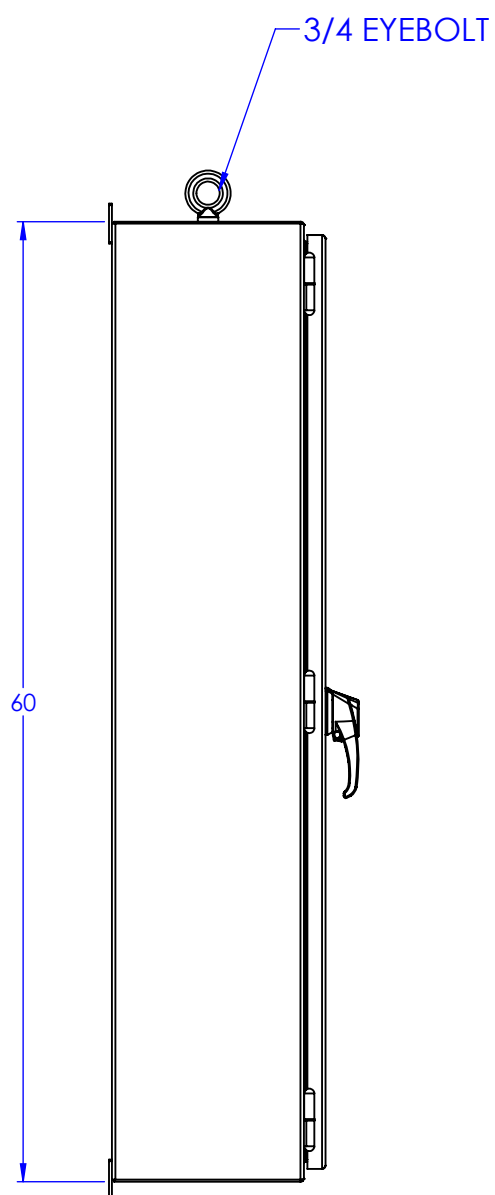
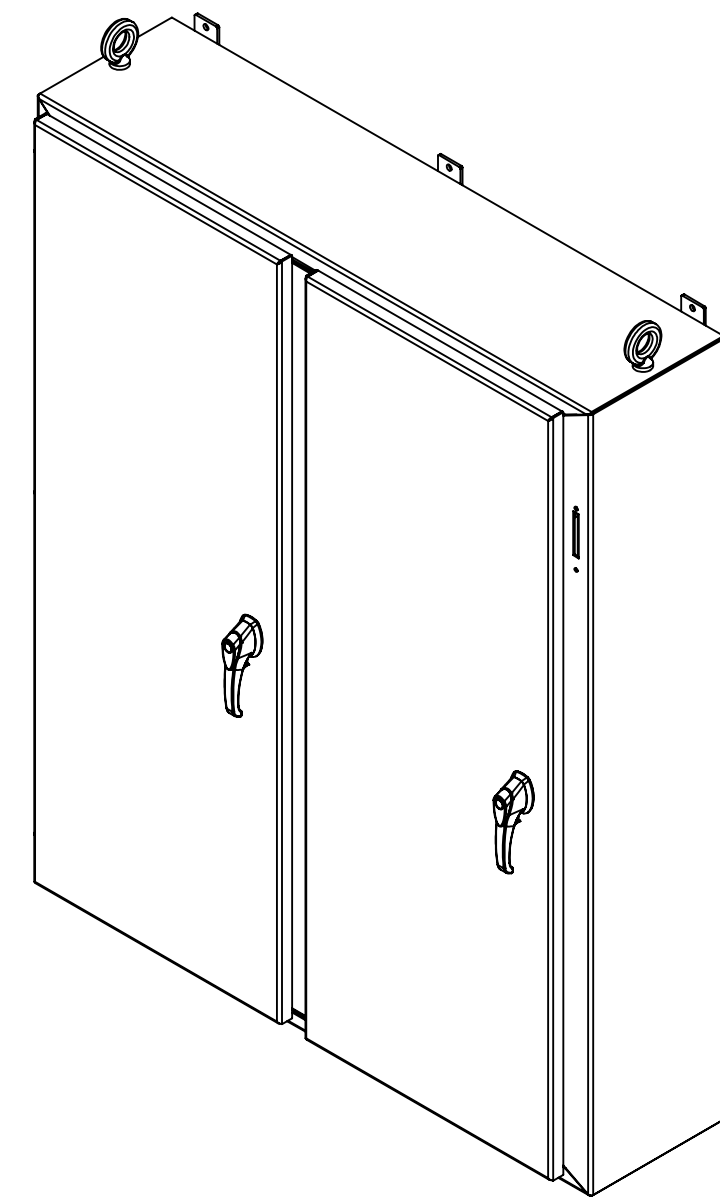
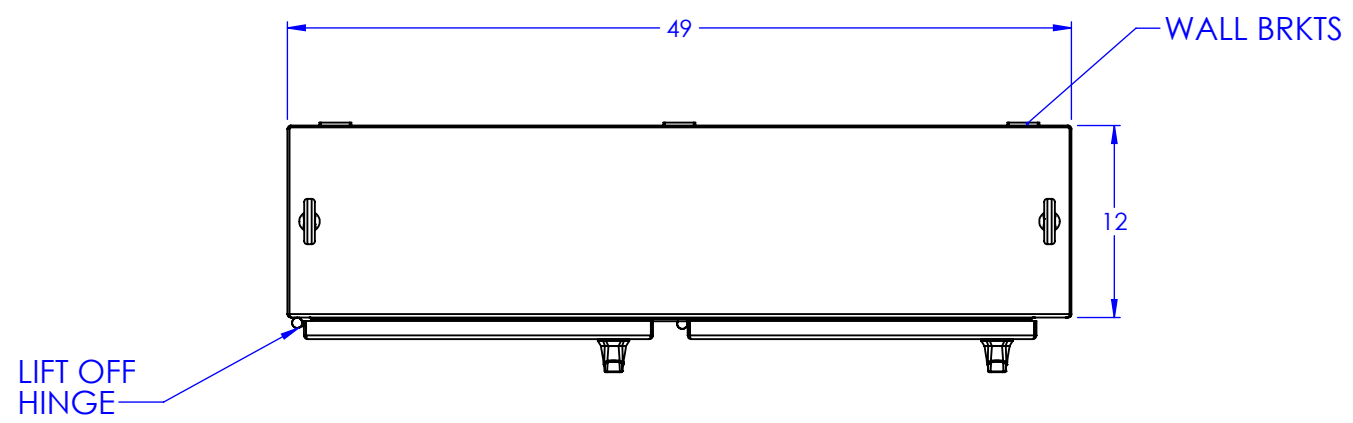

SECTION B-B

PROPRIETARY AND CONFIDENTIAL THE INFORMATION CONTAINED IN THIS DRAWING IS THE SOLE PROPERTY OF RALSTON METAL PRODUCTS. ANY REPRODUCTION IN PART OR AS A WHOLE WITHOUT THE WRITTEN PERMISSION OF RALSTON METAL PRODUCTS IS PROHIBITED. UNLESS OTHERWISE SPECIFIED DIMENSIONS ARE IN INCHES TOLERANCES: FRACTIONAL ± 1/32" ANGULAR ± 0.031° ONE PLACE DECIMAL ± 0.1" TWO PLACE DECIMAL ± 0.01" THREE PLACE DECIMAL ± 0.005" MATERIAL: SEE BOM FINISH: SEE BOM DO NOT SCALE DRAWING	NAME: _____ DATE: _____ DRAWN BY: _____ ISSUED BY: _____ JOB ORDER NO.: _____	50 WATSON ROAD QUELPS, ONTARIO N7L 1E2 PHONE: (519) 836-2968 TOLL FREE: 1-800-265-7611 FAX: (519) 836-9793 Ralston Metal Products Limited WWW.RALSTONMETAL.COM	
	CUSTOMER DRAWING NO.: _____ SHOP DRAWING NUMBER: _____	SIZE: _____ PART NAME: _____ REV: _____	CUSTOMER: _____
	(AUTHORIZED SIGNATURE IN RED) 	PART NO.: 2000-FM-604912 SCALE: 1:12 WEIGHT: _____ SHEET 1 OF 1	CUSTOMER: _____
	THIRD ANGLE PROJECTION	PART NO.: 2000-FM-604912 SCALE: 1:12 WEIGHT: _____ SHEET 1 OF 1	CUSTOMER: _____