

1 2 3 4

REVISION				
REV.	ECO	REV. BY	DATE	DESCRIPTION
A	-	SMS	01/19/2001	-
B	-	JAM	05/05/2002	ADDED MOUNTING PAN

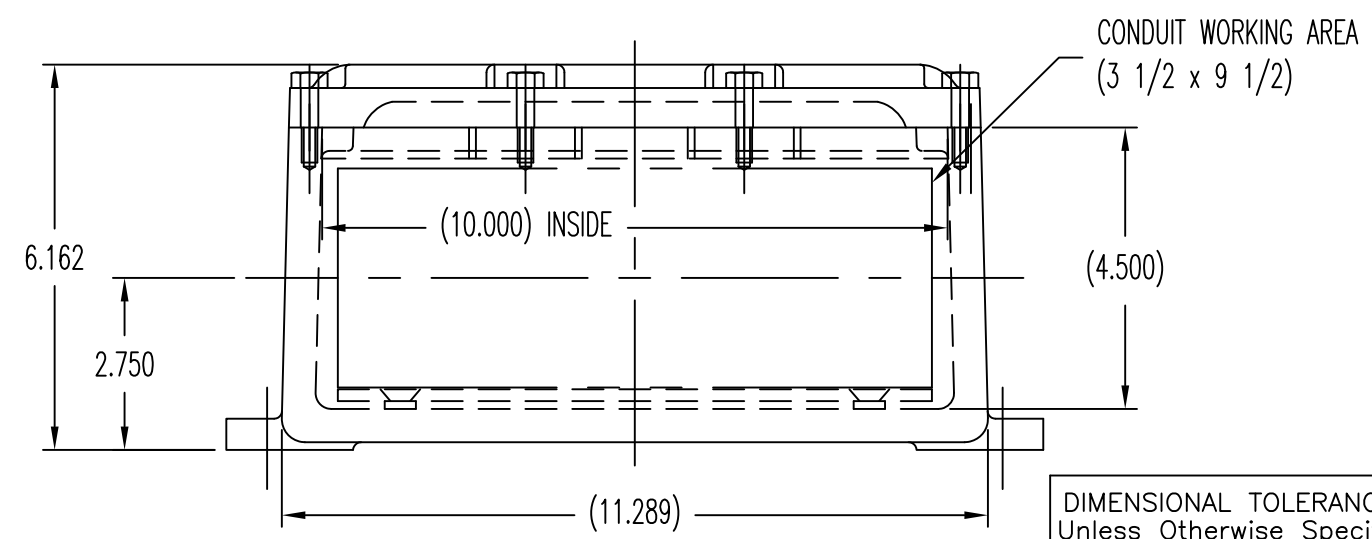
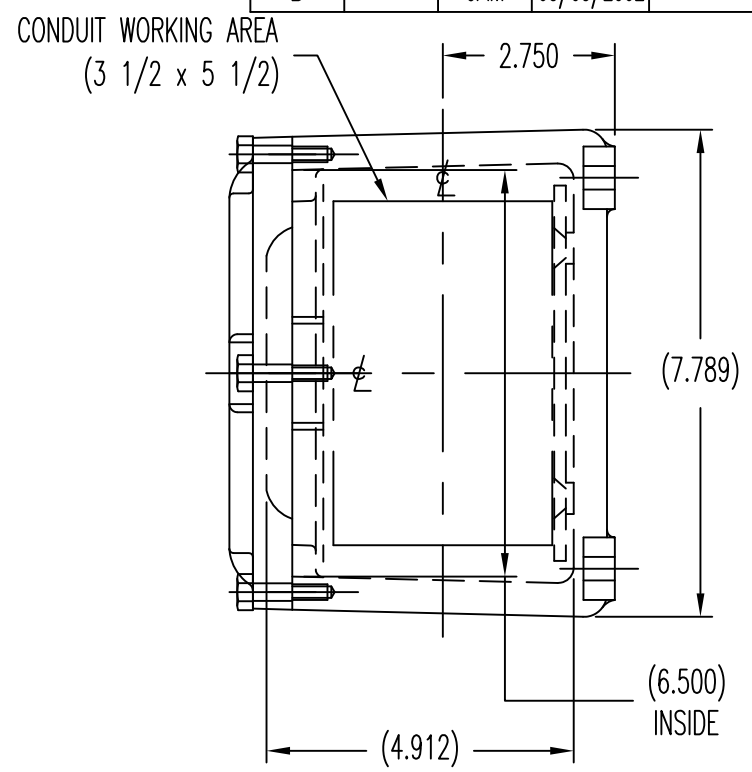
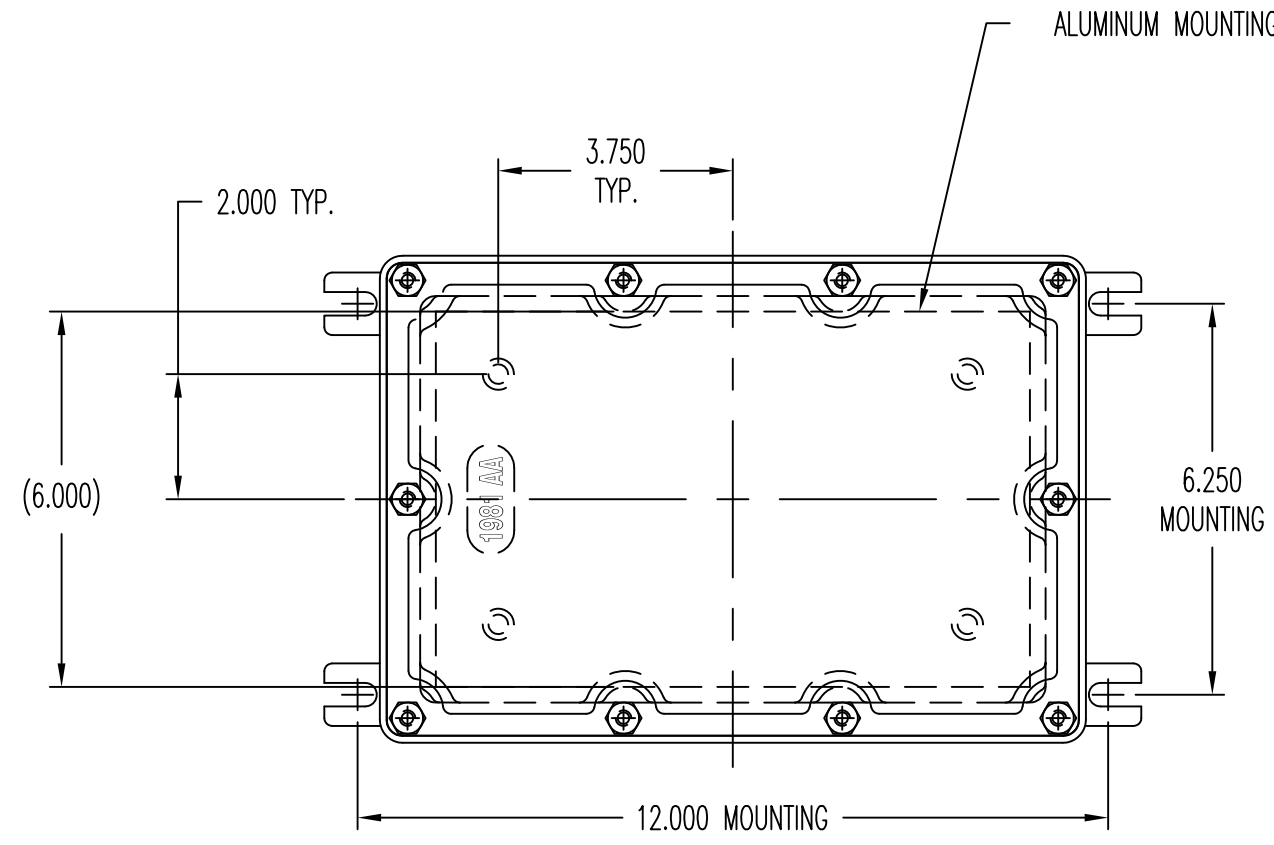

DIMENSIONAL TOLERANCES  
Unless Otherwise Specified

.X ±0.015  
.XX ±0.010  
.XXX ±0.005

ANG. ±1/2°  
FRAC. ±1/64

DO NOT SCALE DRAWING  
REMOVE ALL BURRS

DWG. FILE AXI6104

THIS DRAWING IS THE PROPERTY OF THE AKRON ELECTRIC INC. AND IS ISSUED TO THE RECIPIENT WITH THE UNDERSTANDING THAT IT SHALL NOT BE COPIED, DUPLICATED, PASSED ON TO OTHER PARTIES, NOR USED FOR ANY PURPOSE OTHER THAN THAT FOR WHICH IT IS SPECIFICALLY FURNISHED EXCEPT WITH OUR WRITTEN PERMISSION.

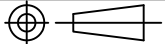
ITEM	QTY.	PART NO.	PART NAME	DESCRIPTION
 <b>AKRON ELECTRIC, INC.</b> AKRON, OHIO				
DRAWN	SMS	CHKD. BY	SCALE 1=3	PROJECTION 
DATE	01/19/2001	DATE CHKD.	CAT. NO. AXI/CXI 6104	PAGE 1 OF 1
DESC. AXI / CXI 6104				
TITLE <b>OUTLINE / LAYOUT - AXI/CXI 6104</b>				
MATERIAL	AL 357	DWG. NO.	6104	REV. B

D  
C  
B  
A