

1 2 3 4

REVISION				
REV.	ECO	REV. BY	DATE	DESCRIPTION

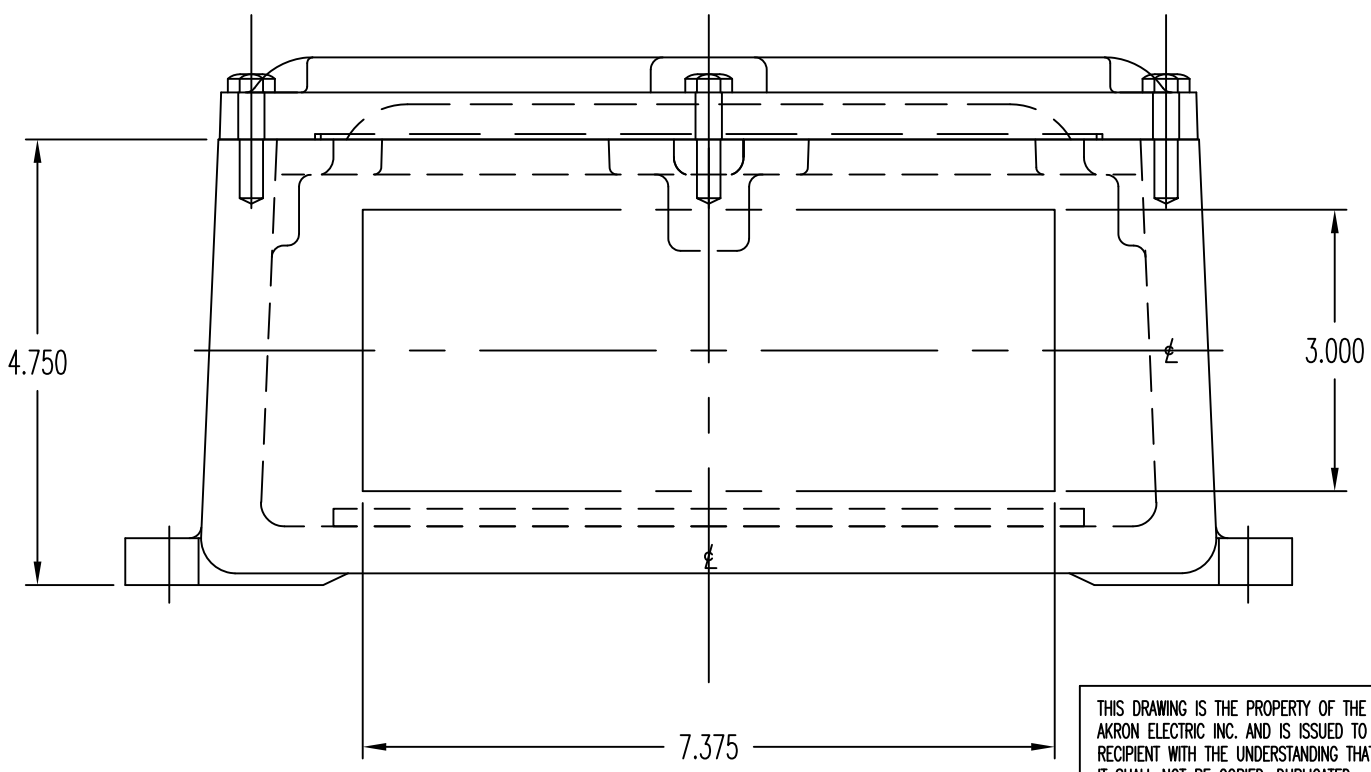

DIMENSIONAL TOLERANCES  
Unless Otherwise Specified

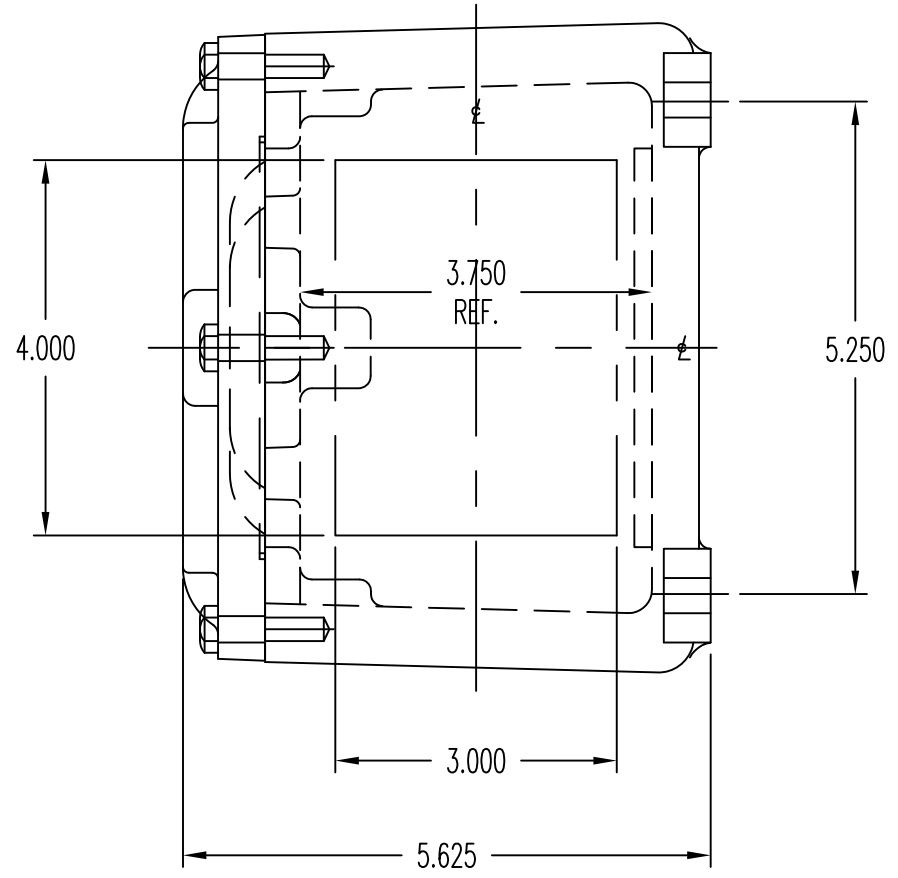
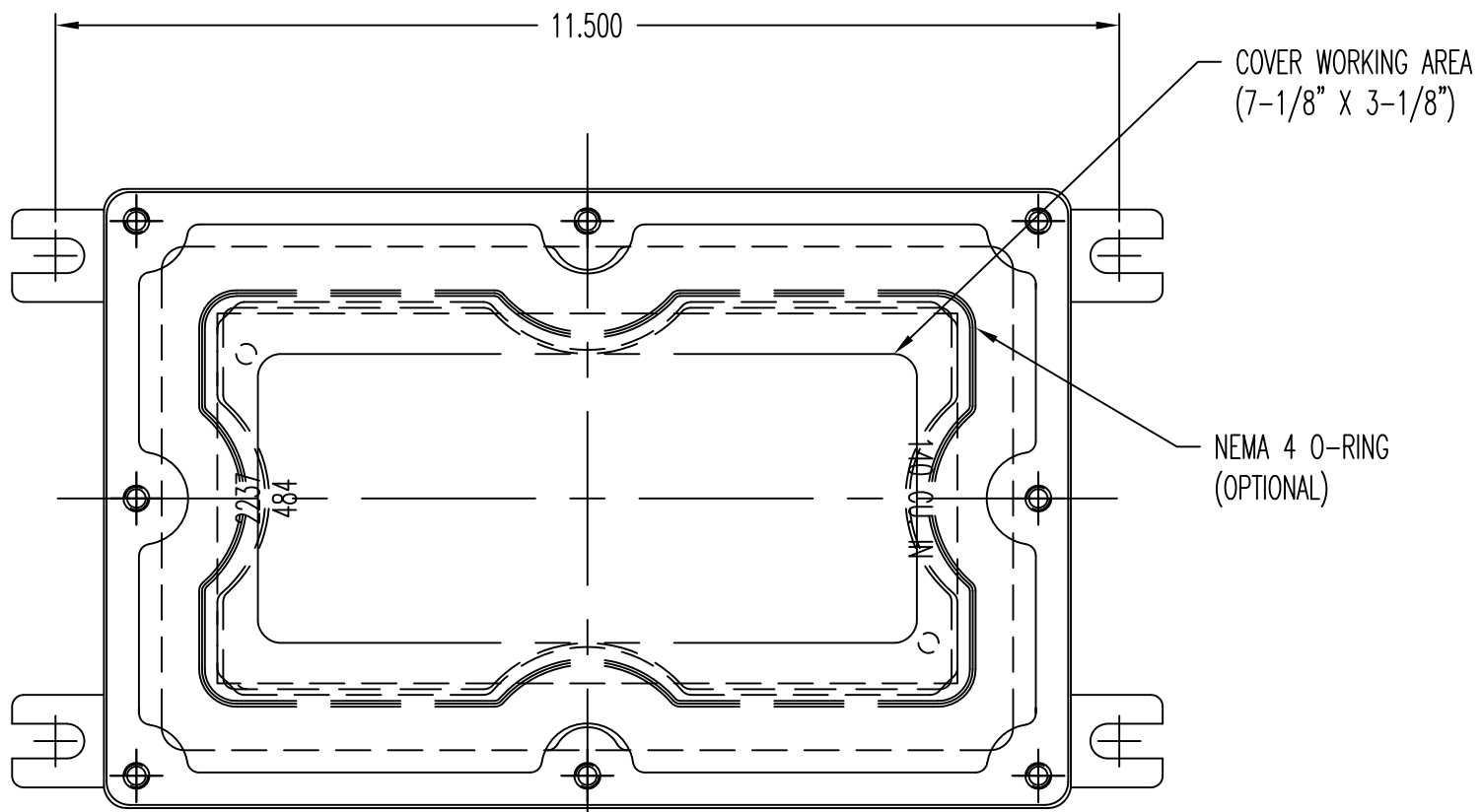

.X ±0.015  
.XX ±0.010  
.XXX ±0.005

ANG. ±1/2°  
FRAC. ±1/64

DO NOT SCALE DRAWING  
REMOVE ALL BURRS

DWG.FILE AXI484.DWG

THIS DRAWING IS THE PROPERTY OF THE  
AKRON ELECTRIC INC. AND IS ISSUED TO THE  
RECIPIENT WITH THE UNDERSTANDING THAT  
IT SHALL NOT BE COPIED, DUPLICATED,  
PASSED ON TO OTHER PARTIES, NOR USED  
FOR ANY PURPOSE OTHER THAN THAT FOR  
WHICH IT IS SPECIFICALLY FURNISHED EXCEPT  
WITH OUR WRITTEN PERMISSION.

ITEM	QTY.	PART NO.	PART NAME	DESCRIPTION
 <b>AKRON ELECTRIC, INC.</b> AKRON, OHIO				
DRAWN	JAM	CHKD. BY	SCALE 1=2	PROJECTION 
DATE	01/17/2005	DATE CHKD.	CAT. NO. AXI/CXI	PAGE 1 OF 1
DESC.		AXI / CXI484 CL.I, DIV 1&2, GR. BCD; CL. II, DIV 1&2, GR. EFG; CL.III		
TITLE OUTLINE / LAYOUT AXI/CXI484				
MATERIAL	AL357	DWG. NO.	AXI/CXI484	REV. A

D  
C  
B  
A